

40-CHANNEL CB—READY JAN. 1

\$1.00 ■ JAN. 1977

# Radio-Electronics

THE MAGAZINE FOR NEW IDEAS IN ELECTRONICS

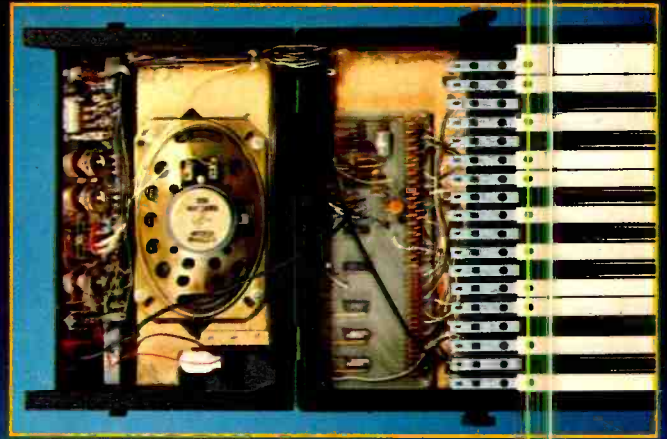

make with ICs  
**DIGITAL CAR CLOCK**  
put it anywhere

5 full octaves  
**KEYBOARD SYNTHESIZER**  
you can build

General Instrument  
**IC DATA SHEET**  
for video games

how we check  
**NOISE MEASUREMENTS**  
in hi-fi gear

all about  
**ANALOG MULTIMETERS**  
for everyone

## PLUS

- ★ More About TV Games
- ★ Jack Darr's Service Clinic
- ★ Step-By-Step T...
- ★ Komputer
- ★ State Of S...
- ★ Lab Tested reports of **Yamaha B2** and **Sony STR-6800**

561296 0LS 80249M97 14 A MAR77  
H M OELSCHLAGER  
BOX 245  
01

A  
HERNSBACK  
PUBLICATION



# Remote Control Racer



*A new fun  
leisuretime activity  
made possible by  
the new electronics.*

*Computer logic has  
added a new fun way to  
control remote control products.*

The Remote Control Racer is a competition scale model race car controlled by a transmitter using computer logic.

Think of it. Remotely drive a model race car from as far as sixty feet—turning left and right, going forward and reverse. It's great fun for hobbyists, children and the whole family.

#### **DIGITALLY PROPORTIONAL CONTROL**

The steering is controlled as you control the steering wheel on your remote control unit. Turn the wheel slightly to the right and the car wheels turn slightly to the right. Turn your control fully to the left and the car wheels turn fully to the left.

There is no transmission required to go from forward to reverse as the high quality servo motor simply reverses polarity to change gears. Press the forward lever on your remote unit and you go forward. Press the reverse lever and you go in reverse. It's just that quick.

#### **BUILT TO THE FINEST DETAIL**

The camber caster-action front wheels parallel a full-sized car's suspension system and they actually tilt on the turns. An independent floating rear axle maintains positive traction even on rough terrain.

The Remote Racer replaces the gasoline powered remote control race cars that have

The Remote Control Racer is a well built, well engineered electronic instrument with a 90 day limited warranty. JS&A further guarantees your satisfaction—if you are not absolutely satisfied with the value, quality or fun you are having, fine—return your racer within ten days for a full refund. You can't lose.

To order, credit card buyers simply call our toll-free number below and specify the color and quantity you want. Or send a check for \$52.45 (\$49.95 for each Racer plus \$2.50 for postage, insurance and handling to the address shown below. (Ill. residents add 5% sales tax).

By return mail, you'll receive a Remote Control Racer, the remote control unit, batteries, a 90 day limited warranty and simple operating instructions. Your unit should never require service but if it should, JS&A's service-by-mail facility is as close as your mail box. JS&A is America's largest single source of space-age products and a substantial company—further assurance that your modest investment is well protected.

Find out the thrill and fun of racing model race cars remotely. Order one or two Remote Control Racers today.

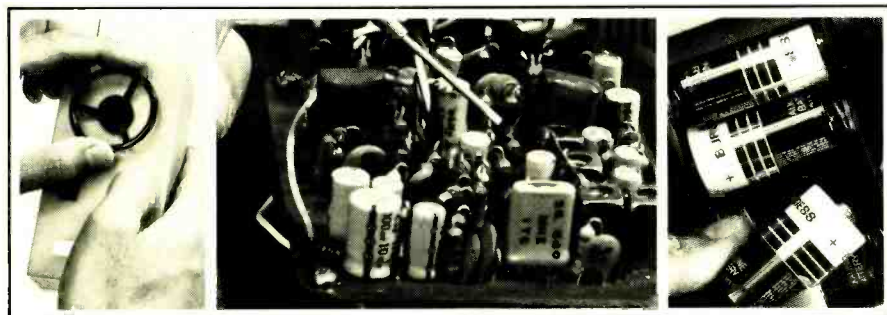

*The remote control unit (left) controls the race car's electronics (center).  
The four "C" cell batteries fit in the underside of the Racer.*

#### **SOPHISTICATED ELECTRONICS**

The sophisticated electronics in the Remote Control Racer consists of 40 transistors. When you operate the control unit, the transmitter generates computer digital logic in a train of digital pulses which then are amplified and transmitted to the racer. The racer then has a sensitive receiver which receives the pulses and in turn translates them into data that eventually translates into power for the car.



*The sleek lines of the Remote Control Racer follows the designs of some of the more popular race cars. The car measures 3½" x 5" x 12".*

sold for well over \$100 a unit. Remote gas powered models give off odors and are often temperamental. The Remote Racer is quiet so it can be run indoors and it is not dangerous so even children can safely play with it.

#### **START A RACE CLUB**

You can run as many as six different cars in a race as each car will be on a separate remote control frequency. There are four different colors available, red, white, blue, and yellow and each racer comes equipped with its matching remote control unit.

Start a local competition race club, entertain guests with your new adult toy, or give it to your children as one of the more prized possessions. There are many fun ways to use your Remote Racer.

There are two separate circuits used for forward and for reverse. Each circuit utilizes two "C" cell batteries available anywhere. If you only go forward, the two forward batteries will last approximately two hours.

**\$49<sup>95</sup>**

**NATIONAL  
INTRODUCTORY  
PRICE**

**JS&A** NATIONAL SALES GROUP

DEPT. RA JS&A Plaza  
Northbrook, Illinois 60062  
CALL TOLL-FREE . . . 800 241-8444  
In Georgia call . . . 800 282-1333

©JS&A Group, Inc., 1976



Now you can buy an Altair™ 8800b or an Altair 680b computer right off the shelf. Altair plug-in boards, peripherals, software and manuals are also available. Check the list below for the MITS dealer in your area.

# off the shelf.

RETAIL COMPUTER STORE, INC.  
Tim & Susanne Brocm  
410 NE 72nd St.  
SEATTLE, WA 98115  
(206) 524-4101

COMPUTER KITS (S. F. area)  
Pete Roberts  
1044 University Ave.  
BERKELEY, CA 94710  
(415) 845-5300

THE COMPUTER STORE  
(Arrowhead Computer Co.)  
Dick Heiser  
820 Broadway  
SANTA MONICA, CA 90401  
(213) 451-0713

GATEWAY ELECTRONICS, INC.  
George Mensik OF COLORADO  
2839 W. 44th Ave.  
DENVER, CO 80211  
(303) 458-5444

COMPUTER SHACK  
Pete Conner  
3120 San Mateo NE  
ALBUQUERQUE, NM 87110  
(505) 883-8282, 883-8283

GLOBAL ENGINEERING CO.  
5416 South Yale  
TULSA, OKLA. 74145  
(918) 452-2567

COMPUTER PRODUCTS UNLIMITED  
Harry & Margaret Mohrmann  
4216 West 12th  
LITTLE ROCK, AR 72204  
(501) 666-2839

GATEWAY ELECTRONICS, INC.  
Harry & Margaret Mohrmann  
Lou Elkins, Stuart Bartfield  
8123-25 Page Blvd.  
ST. LOUIS, MO 63130  
(314) 427-6116

CHICAGO COMPUTER STORE  
Lou Van Eperen  
517 Talcott Rd.  
PARK RIDGE, IL 60068  
(312) 823-2388

THE COMPUTER ROOM  
3938 Beau D'Rue Drive  
Eagan, MN 55122  
Dale Hagert, Bob Raemer  
(612) 452-2567

BYTETRONICS  
John & Stan Morrow  
Suite 103  
1600 Hayes St.  
NASHVILLE, TN 37203  
(615) 329-1979

THE COMPUTER SYSTEMCENTER  
Jim Dunion, Rich Stafford,  
Steven Mann, Ron Roberts  
3330 Piedmont Road  
ATLANTA, GA 30305  
(404) 231-1691

THE COMPUTER STORE, INC.  
Sid Halligan  
120 Cambridge St.  
BURLINGTON, MA 01803  
(617) 272-8770  
Jeff Feldman, Service Dept.

THE COMPUTER STORE OF NEW YORK  
Bob Arning  
55 West 39th St.  
NEW YORK, NEW YORK 10018  
(212) 221-1404

THE COMPUTER STORE OF  
Peter Blond ANN ARBOR  
310 East Washington Street  
ANN ARBOR, MI 48104  
(313) 995-7616

THE COMPUTER STORE, INC. (Hartford area)  
George & Susan Gilpatrick  
63 South Main Street  
WINDSOR LOCKS, CT 06096  
(203) 627-0188

MICROSYSTEMS (Washington, D.C.)  
Gloria & Russell Banks  
6605A Backlick Rd.  
SPRINGFIELD, VA 22150  
(703) 569-1110

THE COMPUTER STORE  
Stephen Payne  
1114 Charleston National Plaza  
CHARLESTON, W. VA. 25301  
(304) 343-4607

MARSH DATA SYSTEMS  
Don Marsh  
5405 B Southern Comfort Blvd.  
TAMPA, FL 33614  
(813) 886-9890



CIRCLE 46 ON FREE INFORMATION CARD

www.americanradiohistory.com



# Sylvania introduces the first 5-year warranty\* on picture tubes.

How can we give you a limited warranty this good?

Because we have complete confidence that our Color Bright 85® picture tubes will outlast this 5-year warranty and keep on giving your customers beautiful pictures.

We produce these tubes on the same equipment as our All-New line which is sold as original equipment to TV set manufacturers.

It's terrific to be able to offer your customers a high-quality tube with a warranty like this at no risk to you. There's good profit in it, too. So get in touch with your local distributor today, and get cracking on your first five years.

**\*Limited Warranty, naturally.  
It doesn't cover labor for replacing a tube.**

**GTE SYLVANIA**

GTE Sylvania, Electronic Components Group, 100 First Ave., Waltham, MA. 02154

[www.americanradiohistory.com](http://www.americanradiohistory.com)



# Radio-Electronics®

THE MAGAZINE FOR NEW IDEAS IN ELECTRONICS

Electronics publishers since 1908

JANUARY 1977 Vol. 48 No. 1

## SPECIAL FEATURES

- 39 **TV Games**  
*Part II*—Final section in this comprehensive look at what you can buy. **by Fred Blechman**
- 61 **IC Application Of The Month**  
Complete information on how to use General Instrument's Video Game IC.

## CB RADIO

- 43 **23 Or 40—When Should You Buy?**  
How to get the most for your money. **by Fred Petras**

## BUILD ONE OF THESE

- 31 **Portable Mini Organ**  
*Part I*: Play music anywhere with this self-contained five-octave organ. **by John S. Simonton**
- 35 **Digital LED Clock For Your Car**  
Accurate four-digit LED clock in a compact size for your dashboard. **by Robert C. Arp**

## COMPUTERS

- 22 **Komputer Korner**  
Generating a UART function using software. **by Paul Field, David Larsen, Peter Rony and John Titus**
- 66 **Timeshare—Turn Your Minicomputer Into A Maxi**  
Your minicomputer can be used to access a full-scale computer system. **by Patrick Godding**

## GENERAL ELECTRONICS

- 4 **Looking Ahead**  
Tomorrow's news today. **by David Lachenbruch**
- 29 **Equipment Report**  
Sencore DVM35 digital voltmeter
- 46 **Analog Voltmeters**  
An in-depth look at how they work and how to use them. **by Charles Gilmore**

## HI-FI AUDIO STEREO

- 26 **Equipment Report**  
Heath AS-1344 Speakers
- 49 **How Noise Is Measured**  
Know what the noise specs mean before you compare. **by Len Feldman**
- 56 **R-E Lab Test Report**  
Sony STR-6800SD Receiver.
- 59 **R-E Lab Test Report**  
Yamaha B-2 Amplifier.

## TELEVISION

- 68 **Step-By-Step Troubleshooting**  
Color bandpass amplifiers. **by Jack Darr**
- 75 **Service Clinic**  
Fast recovery diodes **by Jack Darr**
- 77 **Reader Questions**  
R-E's Service Editor solves reader problems

## DEPARTMENTS

- 88 **Advertising Index**                      80 **New Products**
- 12 **Advertising Sales Offices**            85 **Next Month**
- 14 **Letters**                                      89 **Reader Service Card**
- 6 **New & Timely**

## ON THE COVER

Electronic music organs have been around for quite awhile, but portable organs are really unique. This one is completely self-contained with speaker, battery and keyboard, and it covers a five-octave range. The construction details start of page 31.

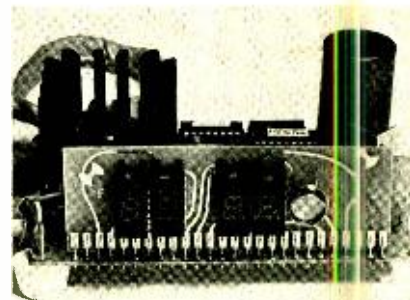

Spice up your car with this Digital LED Clock. The construction details start on page 35.

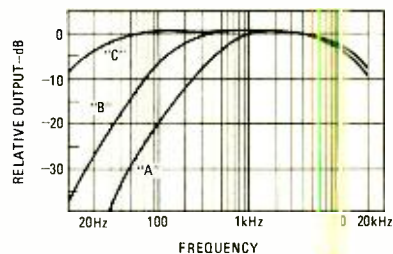

You can't compare noise specs for hi-fi gear unless you know how they are measured. An in-depth look at how noise measurements are made starts on page 49.

**Radio-Electronics**, Published monthly by Gernsback Publications, Inc., 200 Park Avenue South, New York, NY 10003. Phone: 212-777-6400. Second-class postage paid at New York, NY and additional mailing offices. One-year subscription rate: U.S.A., U.S. possessions and Canada, \$8.75. Pan-American countries, \$10.25. Other countries, \$10.75. Single copies \$1.00. © 1976 by Gernsback Publications, Inc. All rights reserved. Printed in U.S.A.

**Subscription Service:** Mail all subscription orders, changes, correspondence and Postmaster notices of undelivered copies (Form 3579) to Radio-Electronics Subscription Service, Box 2520, Boulder, CO 80302.

A stamped self-addressed envelope must accompany all submitted manuscripts and/or artwork or photographs if their return is desired should they be rejected. We disclaim any responsibility for the loss or damage of manuscripts and/or artwork or photographs while in our possession or otherwise.

As a service to readers, Radio-Electronics publishes available plans or information relating to newsworthy products, techniques and scientific and technological developments. Because of possible variances in the quality and condition of materials and workmanship used by readers, Radio-Electronics disclaims any responsibility for the safe and proper functioning of reader-built projects based upon or from plans or information published in this magazine.

# looking ahead

## Projection report

Advent says it produced about 6,000 projection television systems in 1976, and it's doubtful whether the rest of the projection-TV industry—consisting of up to 30 or 40 companies, mostly small—made much more than that all together despite their optimistic forecasts early in the year. Most of the other "home" projection TV manufacturers actually assemble their systems from modified, small-screen color sets, lenses, screens and cabinets. Sony was probably the inspiration for this type of set, having had one on the market for two years (but using a special trinitron tube for high brightness). Some of the larger corporations are beginning to take an interest in projection. Admiral, a subsidiary of Rockwell International, has been experimenting with giant-screen TV, and several months ago Sega Enterprises, a subsidiary of Gulf & Western, purchased a projection television company.

The company it purchased was Muntz Home Theatre, founded by the same "Madman" Muntz who starred in TV's early days with the first low-priced mass-marketed television sets and later introduced car stereo. Now Sega has started to distribute its "Segavision" line of projection TV at \$995 to \$2,395. Meanwhile, Muntz has started up a new company and is back in the projection-TV business. Although his firm's name is Muntz Electronics, he can't advertise it because Sega obtained an injunction, claiming it bought the Muntz name as well as the business. So, with his usual flair for turning a liability into an asset, Muntz is now advertising his company as "Madman Electronics," with sets priced from \$795 to \$1,595.

## 7-hour VTR?

While the debate continues over the optimum playing/

recording time for home video-cassette recorders, Sony is expected to introduce soon an accessory for its enormously successful Betamax that extends unattended recording time to as much as seven hours. The accessory is a changer. In at least one pre-production version seen in Tokyo, the changer's bin permitted the stacking of up to seven one-hour cassettes. The cassettes are changed automatically—a new one drops into place as the previous one is rejected.

The changer, as viewed in prototype, incorporates a digital timer with LED readout, permitting either uninterrupted or on-off-on-off recording while unattended. Thus a night-shift worker could tape all evening programs on one channel from 6 PM to 1 AM for viewing after he came home from work.

## Magnetic disc recorder

For the last three years, this column has reported occasionally on the magnetic disc recorder (MDR) being developed by Erich Rabe as a TV attachment to both record and play back in color. With each demonstration, picture quality has improved (although it has never seemed quite good enough for commercialization), and the major drawback has been its extremely short recording time. Now, even before the short-playing version has been introduced, Rabe has developed an LP version designed to have a playing time of two hours per disc.

The LP disc is understood to be about 1/4-inch thick, looking something like an old Edison record. The outside three inches are composed of magnetic material with deeply-cut grooves. Each groove is designed to accommodate 24 spiral magnetic tracks, which are deposited into the groove wall by the magnetic recording head. The head presumably travels the spiral groove from start to center of the disc, then changes to track two and

repeats the process, and so on, until all 24 tracks have been recorded. The system's promoters say some versions of MDR should be on the market in Europe and the U.S. during 1977. But, as this column has so often warned, don't ever hold your breath waiting for a videodisc.

## Kloss leaves Advent

Henry Kloss, founder of Advent Corporation and one of the leading innovators in American consumer electronics, has left the company of which he was once president and more recently technical director. His main work, he said, was finished with the successful launching of two models of the VideoBeam projection television system. Under Kloss's supervision, Advent also introduced the first consumer Dolby adaptor and the first Dolbyized cassette recorder. Before founding Advent, Kloss was a co-founder of Acoustic Research and KLH, which pioneered air-suspension speakers and compact stereo, respectively. Wherever he shows up next, you can be sure there'll be more innovation.

## TVI crackdown?

Some hints that the FCC may push to force television receiver manufacturers to include interference filtering in all sets were contained in a recent FCC order reiterating its expansion of CB to 40 channels and temporarily rejecting proposals to increase 60-dB harmonic suppression requirement for Class-D CB transmitters. The Commission took a stronger stand than ever before that most of the fault for TVI lies in the TV rather than the transmitter. Said the FCC's decision: "Although it is quite true that harmonic radiation from some Class-D transmitters causes TVI some of the time to some television receivers, it is equal-

ly true that the majority of the TVI complaints received by the Commission result directly from poor TV receiver design, lack of adequate filtering in TV receivers presently on the market, and inability of TV receivers adequately to reject unwanted or adjacent-channel signals. Indeed, in fiscal 1975, 82% of all RF interference complaints were traced to home entertainment equipment design deficiencies."

In the last Congress, three bills aimed at putting the onus of TVI on the TV receiver manufacturers' backs failed to reach a hearing or a vote—possibly because the FCC declined to take a stand on them. The Commission currently has no power to require receiver manufacturers to include interference-protection in their sets. Set makers generally provide filters on request, usually without charge.

With the rapid growth of CB, the FCC's recent statements may indicate it plans to take a stronger stand and possibly request authority to regulate receivers. At the same time, the Commission proposes to tighten up harmonic suppression standards in CB transmitters, perhaps to 100 dB—but probably not this year.

## Antenna warning

Be careful—your CB antenna could be lethal. The Consumer Product Safety Commission says it's studying the problem of what to do about the hazard of electrocutions from base-station antennas as result of their coming into contact with high-voltage lines. The Commission says about 30 people were killed in the first four months of 1976 as the result of such mishaps. The most likely outcome will be a requirement that a strong warning label be printed on packages containing communications antennas, or attached directly to the antennas.

**DAVID LACHENBRUCH**  
CONTRIBUTING EDITOR



# Now... push-button remote TV control... for all channels... for all TV sets.



Jerrold's new all-channel Universal TV Remote Control, Model TRC-82, provides instant push-button selection of *all* TV channels, UHF as well as VHF. Your customers will love the ease with which UHF channels pop in. Tuning is electronic with direct access to the desired channel. There are no motors and no movement, eliminating wear and tear on the TV tuner.

See us at  
C.E.S., Exhibit  
E-206

The TRC-82 can be attached to the back of *any* Color or Black and White TV set in minutes. It turns the set on and off and fine tunes, in addition to changing channels. The TRC-82 also amplifies incoming signals and eliminates direct pick-up ghosts for better picture quality.

Once you demonstrate this new electronic, all-channel TV Remote

Control, your customers won't want to be without it!

It's packaged in a sturdy, colorful, self-selling carton.



**JERROLD ELECTRONICS**

GENERAL INSTRUMENT CORPORATION



JERROLD ELECTRONICS CORPORATION • 200 Witmer Road • Horsham, Pennsylvania 19044 • (215) 674-4800

CIRCLE 28 ON FREE INFORMATION CARD

[www.americanradiohistory.com](http://www.americanradiohistory.com)

## Third Marisat now in orbit; will aid Navy, act as standby

An addition to the two Marisat satellites now in use was launched by NASA last October into an orbit over the Indian Ocean. It will be used by the Navy. Its position is 73 degrees east longitude, near the Maldive Islands, south of India. The present Atlantic Marisat is at 15 degrees West and the Pacific satellite at 176 degrees East. They are relaying high-quality voice, Telex, facsimile and data over both oceans for ships and off-shore oil drilling crews. They also serve the Navy's fleet communications requirements.



**THE THIRD MARISAT SATELLITE** undergoes during tests at the space facility of its builders, Hughes Aircraft Co. The new satellite is stationed over the Indian Ocean, where it will handle Navy communications and serve as standby for Comsat commercial service.

Besides its Navy use, the new satellite will be an in-orbit spare for commercial service, and can be moved to an Atlantic or Pacific position if needed.

Comsat General Corp., for whom Hughes Aircraft Co. built the satellite, reports that some 26 commercial vessels were equipped with shipboard terminals for Marisat use by early Fall 1976. Customers were paying \$10 a minute for telephone calls and \$6 a minute for Telex messages.

Users of the system report a notable

improvement in speed and reliability over surface radio. Exxon, testing the system on five of its tankers, reports that Telex messages by satellite were being received immediately, while messages by the older marine radiotelegraph took over five hours to get through in some cases.

## One thousand CB clinics to study 40-channel band

Sencore, manufacturer of electronic testing and manufacturing equipment, will hold more than 1000 CB service clinics throughout the country, beginning late 1976 and continuing through this Spring. The clinics will be directed at the new 40-channel Class-D CB spectrum and will be carried on with the help of Sencore's two new pieces of equipment, the CB41 Automatic Performance Tester and the CB42 CB Analyzer.

The clinics will cover the technical needs of both field service and bench technicians, the CB41 being adapted to field work, including installations, and the CB42 totally equipping a bench for CB servicing. Both are designed to save the technician's time, making measurements by pushbutton that formerly required adjusting several controls.

Information as to dates and locations of the clinics may be obtained from any of Sencore's Full Line Promotional Distributors.

## ISCET names Technician of the Year

James E. Harris, CET, service manager of Tarpley's TV, Temple, TX, was named "Technician of the Year" by the International Society of Certified Technicians (ISCET) at their convention in San Antonio, TX, last August 15.

The award winner is determined on the basis of scores received in professional proficiency, efficiency, product productivity and customer relations, and in industry and community involvement.

Mr. Harris was nominated by the Twin Lakes chapter of the Texas Electronics Association (TEA) which he serves as secretary-treasurer and ISCET certification administrator, and was selected in balloting conducted by *Service Shop* magazine and ISCET.

The new Technician of the Year, besides his professional and association work, serves on the technical education advisory board of Central Texas College, teaches night classes at Temple Junior College and conducts numerous training sessions for area technicians.

Both the Technician of the Year and the runnerup received watches incorporating the ISCET logo and the statement "Technician of the Year 1976." Both awards are provided by **Radio-Electronics** magazine.

*continued on page 12*



**CB CLINIC IN ACTION.** The CB41, left, and CB42, right, with PS43 power pack between, and Sencore's chief field engineer Greg Carey in foreground.



# All SBE 23-channel CB units have a 40-channel future.

With all the talk about 40-channel CB units tomorrow, why should you buy SBE 23-channel units today?

Simple. We just give you the chance to buy today with tomorrow in mind.

Which is what the SBE FUTURE-40 CB UPDATE PROGRAM is all about. Here's how it works: We're including a special Future-40 Certificate with all SBE 23-channel units. It entitles the SBE buyer to update his 23-channel unit to 40 channels



A Future-40 CB Update Program Certificate comes packed in each of the following SBE units: Coronado II (SBE-10CB), Cortez (SBE-21CB), Formula "D" (SBE-26CB), Catalina III (SBE-29CB), Touch 'Com (SBE-32CB), Brute (SBE-34CB), Trinidad (SBE-14CB), Trinidad II (SBE-30CB), Sidebander II (SBE-42CB), Sidebander IV (SBE-27CB), Console II (SBE-16CB), Console IV (SBE-28CB)

within 1977.

You send in the certificate, we'll set up the update of your unit to a full 40 channels. All, for a reasonable charge, depending on the model involved.

Simple as that.

All in all, the SBE Future-40 CB Update Program is aimed to hit those people who'd like to buy now, but are a bit confused about what's around the corner.

And thinking ahead, about what's around the corner, that's what SBE is all about.



**Better Communications through Creative Technology**

For information write: SBE, Inc., 220 Airport Blvd., Watsonville, CA 95076

INTERNATIONAL OFFICES: E. S. Gould Marketing Co. Ltd., Montreal, Canada/Linear Systems S.A. Geneva 1, Switzerland

CIRCLE 48 ON FREE INFORMATION CARD  
[www.americanradiohistory.com](http://www.americanradiohistory.com)

# Learn to service Communications /CB equipment at home...with NRI'S COMPLETE COMMUNICATIONS COURSE

**Learn design, installation and maintenance of commercial, amateur, or CB communications equipment.**

The field of communications is bursting out all over. In Citizens Band alone, class D licenses grew from 1 to over 2.6 million in 1975, and the FCC projects about 15 million CB'ers in the U.S. by 1979. That means a lot of service and maintenance jobs . . . and NRI can train you at home to fill one of those openings. NRI's Complete Communications Course covers all types of two-way radio equipment (including CB), AM and FM



Transmission and Reception, Television Broadcasting, Microwave Systems, Radar Principles, Marine Electronics, Mobile Communications, and Aircraft Electronics.

The course will also qualify you for a First Class Radio Telephone Commercial FCC License or you get your tuition back.

**Learn on your own 400-channel digitally-synthesized VHF transceiver.**

You will learn to service all types of communication equipment, with the one unit that is designed mechanically and electronically to train you for CB, Commercial and Amateur communications: a digitally-synthesized 400-channel VHF transceiver and AC power supply. This 2-meter unit gives you "Power-On" training. Then we help you get your FCC Amateur License with



special instruction so you can go on the air.

The complete course includes 48 lessons, 9 special reference texts, and 10 training kits. Included are: your own electronics Discovery Lab, Antenna Applications Lab, CMOS Frequency Counter, and an Optical Transmission System. You'll learn at home, progressing at your own speed, to your FCC license and into the communications field of your choice.

## NEW CB SPECIALIST COURSE NOW OFFERED



NRI now offers a special course in CB Servicing. You get 37 lessons, 8 reference texts, your own CB Transceiver, AC power supply and multi-meter . . . for hands-on training. Also included are 14 coaching units to make it easy to get your commercial radio telephone FCC license—enabling you to test, install, and service communications equipment.



# NRI offers you five TV/Audio Servicing Courses

NRI can train you at home to service TV equipment and audio systems. You can choose from 5 courses, starting with a 48-lesson basic course, up to a Master Color TV/Audio Course, complete with designed-for-learning 25" diagonal solid state color TV and a 4-speaker SQ™ Quadraphonic Audio System. NRI gives you both TV and Audio servicing for hundreds of dollars less than the two courses as offered by another home study school.



All courses are available with low down payment and convenient monthly payments. All courses provide professional tools and "Power-On" equipment along with NRI kits engineered for training. With the Master Course, for instance, you build your own 5" wide-band triggered sweep solid state oscilloscope, digital color TV pattern generator, CMOS digital frequency counter, and NRI electronics Discovery Lab.



™ Trademark of CBS Inc.

# NRI's complete computer electronics course gives you real digital training.

Digital electronics is the career area of the future . . . and the best way to learn is with NRI's Complete Computer Electronics Course. NRI's programmable digital computer goes far beyond any "logic trainer" in preparing you to become a computer or digital technician. With the IC's in its new Memory Kit, you get the only home training in machine language programming . . . experience essential to trouble shooting digital computers. And the NRI programmable computer is just one of ten kits you receive, including a TVOM and NRI's exclusive electronics lab. It's the quickest and best way to learn digital logic and computer operation.

**You pay less for NRI training and you get more for your money.**

NRI employs no salesmen, pays no commissions. We pass the savings on to you in reduced tuitions and extras in the way of professional equipment, testing instruments, etc. You can pay more, but you can't get better training.

**More than one million students have enrolled with NRI in 62 years.**

Mail the insert card and discover for yourself why NRI is the recognized leader in home training. No



salesman will call. Do it today and get started on that new career.

**APPROVED UNDER GI BILL**  
if taken for career purposes Check box on card for details.



**NRI SCHOOLS**  
McGraw-Hill Continuing Education Center  
3939 Wisconsin Avenue,  
Washington, D.C. 20016

**Hugo Gernsback** (1884-1967) founder  
**M. Harvey Gernsback**, KOD-6694  
 editor-in-chief and publisher  
**Larry Steckler**, KTX-3644, CET, editor  
**Robert F. Scott**, CET, W2PWG,  
 KXK-8533, technical editor  
**Arthur Kleiman**, KTZ-3288, associate  
 editor

**Jack Darr**, CET service editor  
**Leonard Feldman**  
 contributing high-fidelity editor  
**Karl Savon**, semiconductor editor  
**David Lachenbruch**, contributing editor  
**Rudolph F. Graf**, contributing editor  
**George Whalen**, contributing editor  
**Vincent P. Cicenia**, production manager  
**Dale Allinson**, production assistant  
**Harriet I. Matysko**, circulation director  
**Shella Wertling**, circulation assistant  
**Arline R. Bailey**, advertising coordinator

Cover design by Louis G. Rubsamen  
 Cover photo by Walter Herstatt

**Radio Electronics** is a member of the  
*Institute of High Fidelity* and is indexed in  
*Applied Science & Technology Index* and  
*Readers Guide to Periodical Literature*.



**Radio-Electronics** magazine is published  
 by Gernsback Publications, Inc.  
 200 Park Ave. S., New York, NY 10003  
 (212) 777-6400

President: M. Harvey Gernsback  
 Vice President: Larry Steckler  
 Treasurer: Carol A. Gernsback  
 Secretary: Bertina Baer

### ADVERTISING SALES

#### EAST

Stanley Levitan, KZA-5580, Sales Manager  
 Radio-Electronics  
 200 Park Ave. South  
 New York, NY 10003  
 (212) 777-6400

#### MIDWEST/Texas/Arkansas/Okla.

Ralph Bergen, KXD-8396  
 Jim Reilly  
 The Ralph Bergen Co.  
 6319 N. Central Ave.  
 Chicago, IL 60646  
 (312) 792-3646

#### PACIFIC COAST Mountain States

Jay Eisenberg, KYF-3277  
 J.E. Publishers Representative Co.,  
 8732 Sunset Blvd.,  
 4th Floor,  
 Los Angeles, CA 90069  
 (213) 659-3810  
 Sales Mart Building  
 1485 Bayshore Blvd., Box 140  
 San Francisco, CA 94124  
 (415) 467-0125

#### SOUTHEAST

J.E. Publishers Representative Co.,  
 214-387-2424

### Bartlett, Kelley and Porter get Gernsback awards

Bob Bartlett, of Walton, NY, is this month's winner of the Hugo Gernsback Memorial Award, a prize given annually to an outstanding student in each of eight leading electronics home-study schools. 39 years old, with four children, and a member of the Midstate Electronic Technicians Association, he is at present enrolled in the National Radio Institute Master TV Servicing Course, and has just completed Unit III with honors. He will receive a check for \$150 from **Radio-Electronics**.



**BOB BARTLETT**

Born and raised on a dairy farm near Walton, NY, he operated his own farm for eight years, when illness forced him to quit work. After receiving cobalt treatments for Hodgkin's disease, he attended the State University at Delhi. He became interested in electronics while studying physics there, and enrolled in the NRI Master Color TV course. Starting to repair a few TV's and radios, by 1974 business had increased to the point that it became a full-time operation. Again he had to stop work for some time for health reasons, but at present is working nearly full time and hopes to complete his course in 1976. Bob's only regret is that he did not get started in electronics earlier.

Through the generosity of two test equipment manufacturers, it is possible to make awards to the second and third place entrants in each of the monthly contests. Runner-up this month is Joseph M. Kelley of Grafton, WV. He receives a B & K model 280 Digital Multimeter. After taking an industrial training course in radio and electronics, Mr. Kelley enrolled in the NRI Master course, constructing his own test equipment in the evenings. He now expects to purchase a local TV service business on completing his

course and become "a multi-faceted electronics technician."



**JOSEPH M. KELLEY**

Third-place winner, who will receive a VIZ WV-529A special service VOM, is Richard R. Porter, Jr., a high school senior in Whitesboro, NY. Electronics has been his hobby from the age of 11, and at 16 he decided to make electronics his career. Finding no suitable training locally, he enrolled in the NRI Master TV/Audio servicing course and hoped to have it completed before starting college this Fall. He is working at a local fast-food outlet to pay for the course, and adds to his income by fixing radios and 8-tracks.



**RICHARD R. PORTER, JR.**

He plans to use his TV training to work his way through college by repairing TV's and stereos in the dorms, and to graduate as an electrical engineer with an electronic technician's training.



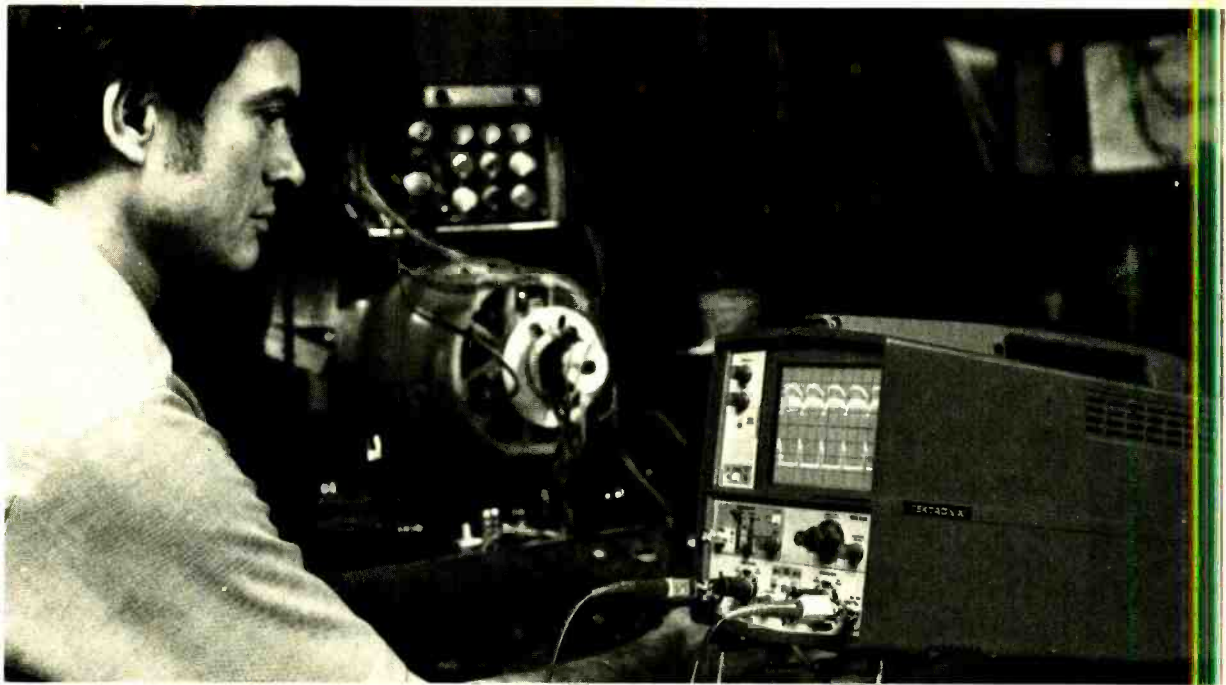

## Now you can service with a TEKTRONIX Oscilloscope for as little as \$695\*

Cost of service instruments is an important factor in any purchase. But so is reliability. Now T900 Oscilloscopes give you both Tektronix quality *and* reliability at prices *designed* for cost sensitive applications.

- T921—Ds to 15 Mhz; single trace,  
single time base ..... \$695\*
- T922—Dc to 15 MHz; dual trace,  
single time base ..... \$350\*
- T932—Dc to 35 MHz; dual trace,  
single time base ..... \$1195\*
- T935—Dc to 35 MHz; dual trace,  
delayed sweep time base ..... \$1395\*
- T912—Dc to 10 MHz; bistable stor-  
age; writing speed to 250  
cm/ms; dual trace, single time  
base ..... \$1300\*

### Performance to Spare

All T900 scopes feature large (8 x 10 cm), bright crt's; sensitivity of 2 mV/div to 10 V/div in twelve calibrated steps; regulated power supplies; and 3% accuracy. T900 Oscilloscopes are also equipped

with important convenience features; beam finder, single knob triggering, automatic selection of chopped or alternate mode, and automatic selection of tv line or frame display (except T912 Storage model). T900 scopes are compact (7x9x 19 in.) and lightweight (only 16 lb.). They are available with a full selection of accessories.

For a demonstration of any T900 Oscilloscope or a free copy of the new T900 brochure, write to Tektronix, Inc., P.O. Box 500, Beaverton, OR 97077. For immediate assistance, call (503) 644-0161, extension T900.

### T900 Series the quality low cost Oscilloscopes



\*All prices include 10X probes. Prices FOB Beaverton, Oregon.



**TEKTRONIX®**  
committed to  
technical excellence

CIRCLE 37 ON FREE INFORMATION CARD

# THE CB PROFIT GENERATOR



Hickok introduces the first low-cost RF generator designed specifically for 40 channel CB service.

**Model 256 \$199.**

Here's every signal you need to service CBs with easy precision tuning over all 40 CB channels. Four additional bands cover 100 kHz to 16 MHz to cover any IF. A counter output gives exact frequency monitoring for precision control. Calibrated RF attenuator output provides stable signals from under 1 microvolt to over 100,000 microvolts. An internal modulator gives a 1 kHz, 0-100% tone, and there are provisions for 20 Hz to 10 kHz external modulation. It's all the RF Generator you need, so why pay more? See your Hickok distributor for more information or contact us directly.

Part of the

**HICKOK**  
Comm Line

the full line of professional CB service instruments.

**HICKOK**  
the value innovator

INSTRUMENTATION & CONTROLS DIVISION  
THE HICKOK ELECTRICAL INSTRUMENT CO.  
10514 Dupont Avenue • Cleveland, Ohio 44108  
(216) 541-8060 • TWX 810-421-8286

# letters

## 4-CHANNEL SOUND

In his article on AM Stereo in the October 1976 issue, Harry Maynard mentioned an interview with 500 people who have lived with quadriphonic systems over a period of time. In this article, Mr. Maynard said that 95% of those interviewed would not want to go back to regular stereo. Although I wasn't one of those interviewed, I agree entirely. I'm a proud owner of an expensive, do-everything quad system, and I couldn't see myself reverting to two-channel sound. But something seems wrong somewhere, and I'm one quadri-freak who isn't going to sit on his woofers and let it happen!

What am I referring to? I'm glad you asked. It's all too obvious that the interest in quad is declining, but it seems to me it's the fault of a closed-minded industry that couldn't care less. No, I DON'T think it's the economy that's killing it. After all, stereo was also somewhat more expensive when it first came out than it is now. I think it's more likely that the bulk of the hardware and software manufacturers are

the ones who are trying their best to lay quad to rest and pull the sod over the grave, but it's a mistake for them to think they can do it.

First point: The industry has failed to come up with a standard for all quad records. If a standard quad system were to be adopted, it would have to offer as much as it can without compromises. I doubt the buying public would settle for less than a totally discrete system that offers compatibility with stereo and mono players. Only one does, and that's CD-4. RCA had the right idea when they first introduced the Quadradisc, and they should have stuck by their guns when WEA made the decision to go double inventory. RCA had also planned to release most new recordings in a single-inventory compatible quad-disc form that, as they said, could take full advantage of any modern stereo or discrete quad system. But RCA reneged on their promise. I wonder if they know it isn't too late?

Second point: Several manufacturers have made quadriphonic receivers and amplifiers that were of very high quality and suddenly pulled them from the market. Sherwood was one of those; they had a fine quadriphonic receiver out that had some good features, such as SQ full logic, and moderate power output, but they yanked it from their line rather suddenly. If the units weren't selling, the blame would have to fall on the retailers, most of whom couldn't be bothered in setting up proper demonstration areas in their stores, and lack of education on the part of both retailer and manufacturer in how to properly present this new medium of sound reproduction. The sales personnel couldn't answer the consumers' questions, and therefore no sale.

Third point: Too many recording companies took a "wait and see" attitude about quad. Capitol released seven "token" efforts, all from their "Custom Products" division, and most were sampler-type albums. MCA's sales department puts the blame on the artists, claiming they were afraid to try four-channel recording. United Artists is about to make their first quad release, an album by Paul Anka, which will be QS-encoded. Perhaps this is just the beginning of a long line of quad recordings yet to come from UA. Polydor/MGM have released two albums in QS, but without mentioning it on either the album cover or the record label. If they plan to go all quad, I know their efforts will be appreciated by many, including myself. A&M started off with QS, tried some SQ, and finally settled on CD-4. But they've had no new quad releases in the past few months. Sounds fishy to me, Herb. There are many more, but it all boils down to the

*continued on page 16*



**save on gas!  
save on tune-ups!  
save on maintenance!**

Electronic ignition is "IN"! So says Detroit.

Update your car with either a TIGER CD or a TIGER I breakerless system.

Enjoy the benefits of better gas mileage, quicker starting, elimination of tune-ups, 50,000 miles on points and plugs, and reduced maintenance expenses.

TIGER MAX CD	\$69.95
TIGER 500 CD	59.95
TIGER SST CD	42.95
SIMPLIKIT CD	31.95
TIGER I	45.95

Postpaid U.S.A. only.

**Tri-Star Corporation**

Dept. WW, P.O. Box 1727  
Grand Junction, Colorado 81501

CIRCLE 7 ON FREE INFORMATION CARD



# The Realistic® SCT-14 gives you far more than just Dolby\*



## at a surprisingly low price!

The Realistic SCT-14 is not just another "me-too" Dolby deck — it's a full-feature model with lots of built-in flexibility to match your stereo system and your taping interests. Switchable Dolby. Selectable bias for CrO<sub>2</sub> and standard tapes. Dual VU meters and exclusive Glide-Path® controls for precise, quality recordings. Five sure-touch function keys, including pause for quick editing. A special cassette eject button.

Auto-Stop at end of tape. Resettable digital counter. And for a professional touch, the indicator/meter panel is angled forward for easy viewing. An output level control matches the deck to any amplifier or receiver. Response: 40-13,000 Hz. Wow and flutter: <0.2%. Simulated walnut grain end panels. And more. It's a Realistic way to enhance your stereo system. Only 149.95†.



**FREE!**

Come in for your copy of our colorful 1977 catalog and see what's really new in electronics. 164 pages. 2000 items.

SOLD ONLY WHERE YOU SEE THIS SIGN:

# Radio Shack®

A TANDY COMPANY • FORT WORTH, TEXAS 76107  
OVER 5000 LOCATIONS IN NINE COUNTRIES

\*"Dolby" is a trademark of Dolby Laboratories, Inc. †Price may vary at individual stores and dealers.

JANUARY 1977

15

# MEET OUR family of High VOLTAGE TEST PROBES

In 1967 we introduced the first high voltage test probe with a built-in meter. It became so popular that we have been adding new models ever since. Now there are five different versions to satisfy the demands of radio, television, appliance, audio, and electrical repair men in a wide variety of high voltage testing applications.

The five models are briefly described below. Our general catalog contains complete applications information, illustrations, specifications, and prices. Write for your free copy.

**MODEL 4242**—42,000 volts DC.  
Negative ground.

**MODEL 3157**—15,000 volts DC.  
Negative ground.

**MODEL 4312**—15,000 volts DC.  
Positive ground.

**MODEL 3163**—6,000 volts DC.  
Negative ground.

**MODEL 3200**—10,000 volts AC.

AVAILABLE THROUGH YOUR  
FAVORITE ELECTRONIC PARTS DISTRIBUTOR

## ITT POMONA ELECTRONICS

1500 East Ninth St., Pomona, Calif. 91766  
Telephone (714) 623-3463, TWX: 910-581-3822



## LETTERS

*continued from page 14*

same thing: WE WANT MORE QUAD SOFTWARE, AND WE WANT IT NOW!

The U.S. Military Overseas market is perhaps the largest for audio components, and quad systems make up a fair portion of the total number of systems sold through the Army and Air Force Exchanges and Navy Resale System. Here in Iceland, the largest and loudest gripe is that there just isn't enough in the way of quad records, particularly CD-4 discs, stocked in the Exchange Stereo Shop. If they were more plentiful they would sell up here like hotcakes. The sales personnel know this and are always trying to get more in, but it's a losing battle. Thing is, it doesn't have to be. If the record companies would get off their duffs and produce more quad recordings, *they would sell!* There are enough quad lovers around who would scarf new quad LP's up hungrily, myself included. If we can make the bigwigs at the record companies know that we're out here, the quad lovers of the world, and that we want more of what we paid good cash for to take advantage of our investments, then maybe we can convince these companies to start pushing again. The second time has to work.

To sum it up, quad doesn't have to die. With hardware vanishing because there isn't enough software, and software vanishing because the hardware is getting scarce, it seems likely that software and hardware manufacturers have to get together and make this thing work. For the software people, it means pushing quad as a single-inventory item, stressing its compatibility (with regard to discs) with existing stereo systems, and getting together on a common system that everyone would use. My vote is for CD-4, but if a matrix system must be adopted, let it be Sansui's QS matrix. As for the hardware folks, they have their work cut out for them as well. They have to make sure these retailers will also present quad with a more positive outlook than they have in the past. Maybe then we can see quadriphonic sound take its rightful place in home entertainment.

JAY L. RUDKO  
FPO, NY

## CORRECTION

Reader Brian Appleman has called our attention to two errors in the Automatic Telephone Dialer article in the November issue. Two resistors marked R12 are shown on the schematic in Fig. 1 and on the component layout in Fig. 6. The resistor connected from ground to pins 6 and 14 of IC12 should be R22. Resistor R22 (100K) is not listed in the parts list.

The schematic in Fig. 1 has diode D20 effectively shorted out by a line connecting its anode and cathode. Remove this line from your schematic.

Reader Richard Alston spotted two circuit elements marked IC6-c in Fig. 1. One is the inverter in the lower left corner of the schematic and the other is the NOR gate used as the blank detector. The inverter is IC6-d with pins 12 and 13 tied together as the input while pin 11 is used as the output.—Editor



# FREE

**THE NEW HEATHKIT CATALOG**  
 the world's largest selection of  
 fun-to-build, money-saving  
 electronic kits!

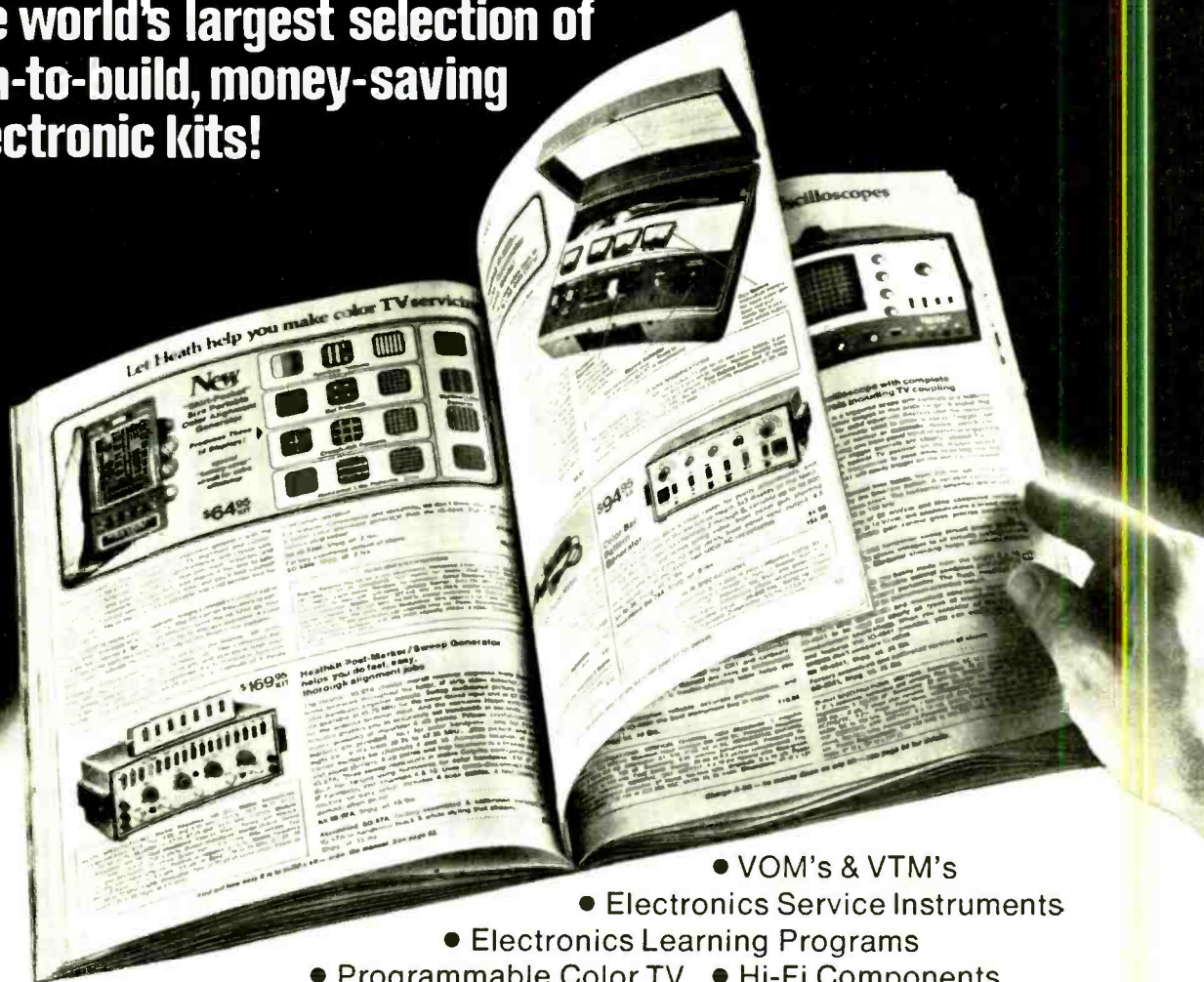

- VOM's & VTM's
- Electronics Service Instruments
- Electronics Learning Programs
- Programmable Color TV • Hi-Fi Components
- Amateur Radio • Radio Control Modeling Equipment
- Digital Clocks & Weather Accessories • Marine, Auto & Aircraft Accessories

Read about the nearly 400 electronic kits you can build and service yourself. The famous Heath assembly manuals guide you every step of the way, and our quality design assures top performance from every kit you build.

**Send for your copy today!**

Heath Co., Dept. 20-25  
 Benton Harbor, Michigan 49022

HEATH <b>Schlumberger</b>	Heath Company, Dept. 20-25 Benton Harbor, Michigan 49022
<b>Please send me my FREE Heathkit Catalog. I am not on your mailing list.</b>	
Name _____	
Address _____	
City _____	State _____ Zip _____
CL-6K 2B	

CIRCLE 100 ON FREE INFORMATION CARD

www.americanradiohistory.com

# The better the training the better you'll

Send for  
**FREE**  
illustrated  
career  
guide

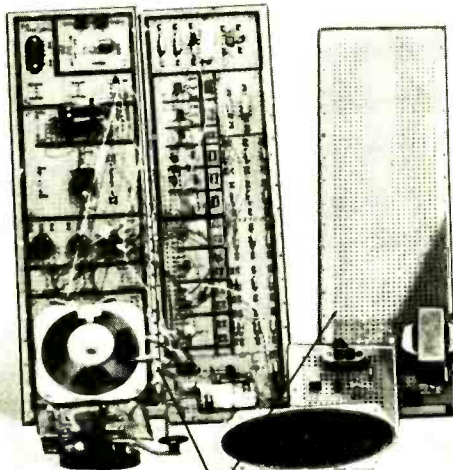
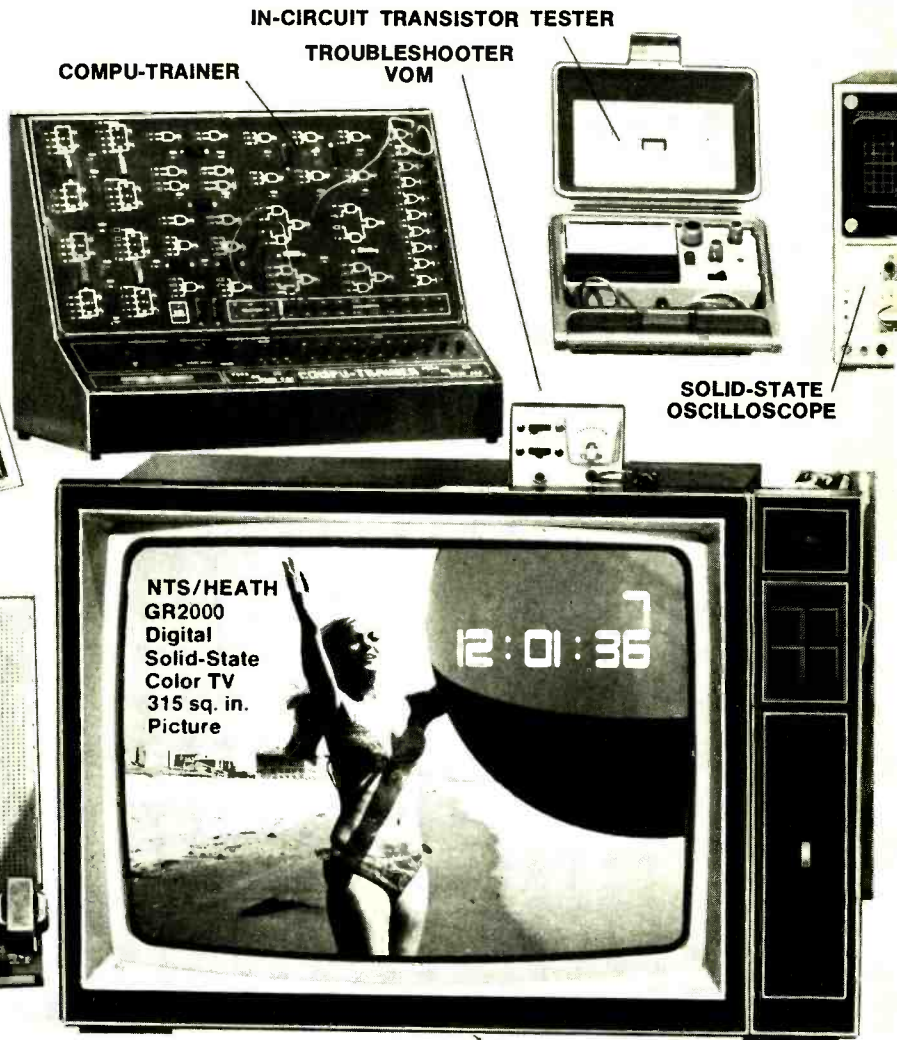
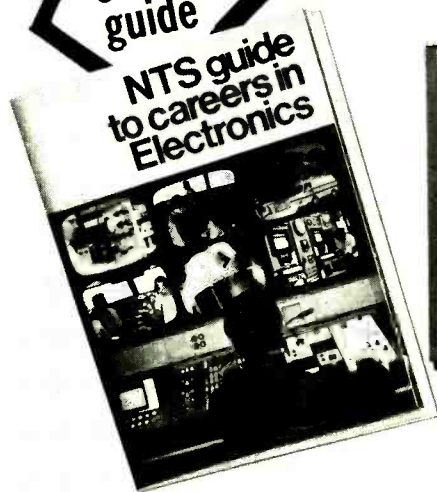

(Simulated TV Reception)

As an NTS student you'll acquire the know-how that comes with first-hand training on NTS professional equipment. **Equipment you'll build and keep.** Our courses include equipment like the **NTS/Heath Digital GR-2000 Solid State color TV** with first-ever features like silent varactor diode tuning; digital channel selection, (with optional digital clock), and big 315 sq. in. ultra-rectangular screen.

Also pictured above are other units — 5" solid state oscilloscope, vector monitor scope, solid-state stereo AM-FM receiver with twin speakers, digital multi-meter, and more. It's the kind of better equipment that gets you better equipped for the electronics industry.

This electronic gear is not only designed for training; it's field-type — like you'll meet on the job, or when you're making service calls. And with NTS easy-to-read, profusely illustrated lessons you learn the theory behind these tools of the trade.

**Choose from 12 NTS courses** covering a wide range of fields in electronics, each complete with equipment, lessons, and manuals to make your training more practical and interesting.

**Compare our training; compare our lower tuition.** We employ no salesmen, pay no commissions. You receive all home-study information by mail only. All Kits, lessons, and experiments are described in full color. Most liberal refund policy and cancella-



# and the equipment be equipped.

**COMPARE OUR  
KITS AND LESSONS.  
COMPARE OUR  
TUITION.**

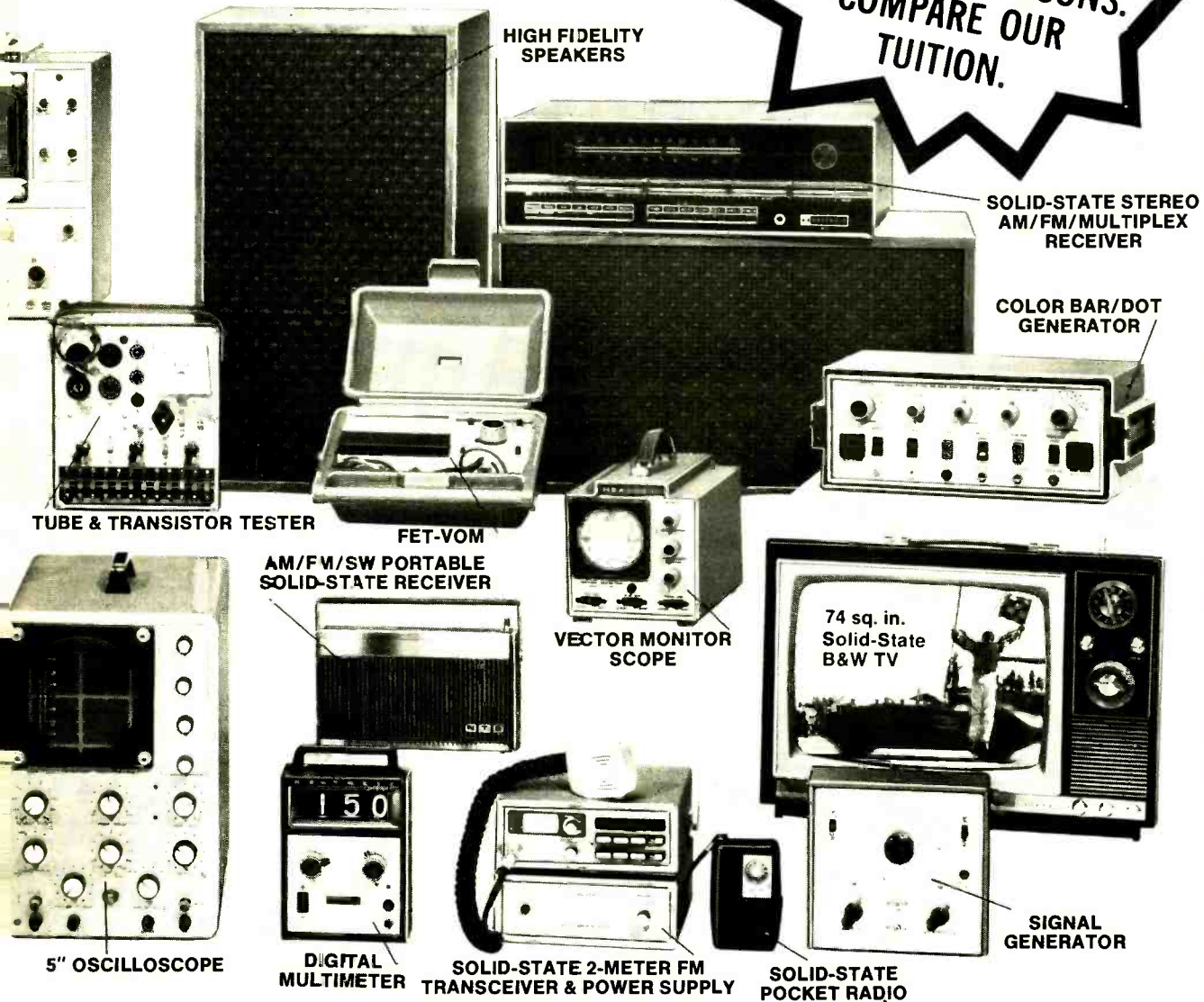

tion privileges spelled out. Make your own comparisons, your own decision. Mail card today, or clip coupon if card is missing.

**NO OBLIGATION. NO SALESMAN WILL CALL**

**APPROVED FOR VETERAN TRAINING**

Get facts on new 2-year extension

**NATIONAL TECHNICAL SCHOOLS**

TECHNICAL-TRADE TRAINING SINCE 1905  
Resident and Home-Study Schools  
4000 So. Figueroa St., Los Angeles, Calif. 90037

**NATIONAL TECHNICAL SCHOOLS**

4000 South Figueroa St., Los Angeles, Calif. 90037

Dept. 206-017

Please send FREE Color Catalog and Sample Lesson.  
NO OBLIGATION. NO SALESMAN WILL CALL.

- |   |  |
|---|--|
| <input type="checkbox"/> Color TV Servicing           | <input type="checkbox"/> Electronics Technology      |
| <input type="checkbox"/> B & W TV and Radio Servicing | <input type="checkbox"/> Computer Electronics        |
| <input type="checkbox"/> Electronic Communications    | <input type="checkbox"/> Basic Electronics           |
| <input type="checkbox"/> FCC License Course           | <input type="checkbox"/> Audio Electronics Servicing |

NAME \_\_\_\_\_ AGE \_\_\_\_\_

ADDRESS \_\_\_\_\_ APT # \_\_\_\_\_

CITY \_\_\_\_\_ STATE \_\_\_\_\_

Please fill in Zip Code for fast service \_\_\_\_\_

- Check if interested in G.I. Bill information.  
 Check if interested ONLY in classroom training in Los Angeles.







# FREE EICO CATALOG

## 358 Ways To Save On Instruments, Citizens Band, Burglar Alarms, Automotive & Hobby Electronics!

The more you know about electronics, the more you'll appreciate EICO. We have a wide range of products for you to choose from, each designed to provide you with the most pleasure and quality performance for your money. The fact that more than 3 million EICO products are in use attests to their quality and performance.

**"Build-it-Yourself" and save up to 50% with our famous electronic kits.**

For latest EICO Catalog and name of nearest EICO Distributor, check reader service card or send 50¢ for fast first class mail service.

**EICO—283 Malta Street,  
Brooklyn, N.Y. 11207**

*Leadership in creative electronics  
since 1945.*



CIRCLE 38 ON FREE INFORMATION CARD

### KOMPUTER KORNER *continued from page 22*

#### Transmit subroutine

The transmit subroutine, shown in Table 1, for the software UART occupies twenty to twenty-five successive program steps in memory once the appropriate PUSH, POP, and RET instructions have been included. Also required is a 9.09 ms time-delay subroutine that corresponds to an asynchronous serial ASCII data transmission rate of 110 Baud, i.e., teletype speed. The program in Table 1 can be described as follows:

Register L is used as the bit counter for the 11-bit ASCII word, and is set initially to octal 013. The seven data-bits plus the parity bit, which is Bit 8, are assumed to be present in the accumulator. At the LO memory address 146, the accumulator is OR'ed to itself to clear the carry bit (shown on the far left in Fig. 2.) In Fig. 2, the least significant data bit

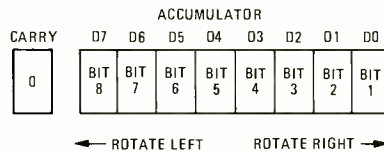
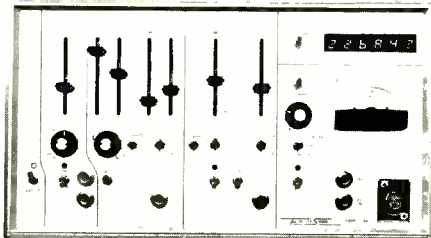

FIG. 2

is Bit 1. At address LO = 147, a RAL instruction is performed to rotate the start bit to bit position D0 in the accumulator. Fig. 3 should provide you with assistance in understanding the four different rotate instructions



**MODEL 100A AUDIO RESPONSE PLOTTING SYSTEM** and general purpose sweep/tone burst/pulse generator consists of two sine /square/triangle function generators, pulse generator, frequency counter and peak amplitude measurement sections. It is primarily intended to generate a frequency response plot on an X - Y recorder or scope.

Time base generator offers symmetrical or independent control of the positive and negative sides of the ramp providing a duty cycle of .7% to 99.3%. Frequency range is .0035Hz to 100kHz. Amplitude is 15Vpp into 500 Ω with ±5VDC offset. The time base output drives the X axis of an X - Y recorder. Manual mode provided for setup.

Audio sweep generator provides manual frequency adjustment or log/linear sweep of 20Hz to 20kHz. Blanking mode produces zero reference line on X - Y recorder or tone burst. Amplitude is 15 Vpp into 500 Ω or 10 Vpp into 8 Ω.

Pulse generator frequency range is .0035Hz to 525kHz. Pulse width is adjusted independent of frequency from 4 seconds to 40 nanoseconds. Outputs are complimentary TTL.

Peak amplitude measurement section measures internal or external signals from mike to power amp level. Amplitude output drives Y axis of X - Y recorder.

Frequency counter is 6 digit, line triggered, and reads either internal or external. Sensitivity is 50 mv peak at 20kHz.

Dimensions: 8 x 14 x 3. Shipping Weight 9 lbs.

\$550, stock to 30 days. Warranty: 1 year.

1894 Commercenter W. #105  
San Bernardino, Ca 92408  
(714) 889-7623



CIRCLE 5 ON FREE INFORMATION CARD

in the 8080A microprocessor instruction set.

At address LO = 150, the start bit is output to the SN7474 data latch. The program then goes into a 9.09 ms time-delay subroutine, after which Bit 1 is rotated into

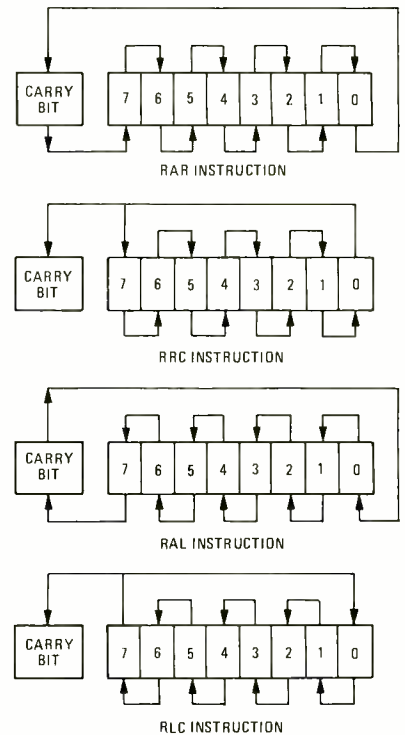

FIG. 3

the D0 accumulator position and the carry bit is set to logic 1. Bit 1 is fed to the SN7474 latch, the ASCII word bit counter in register L is decremented and program control is returned to the time-delay subroutine that is called at address LO = 152. The loop from LO = 152 to LO = 164 is executed a total of eleven times, after which register L becomes zero and the JNZ instruction at address LO = 162 is ignored.

A software UART transmit subroutine possesses a flexibility equivalent to the original 40-pin UART chip. With appropriate modifications to the program or the original accumulator data, you can transmit 5, 6, 7, or 8 data bits; 1 or 2 stop bits; even or odd parity; and parity or no parity. The time-delay subroutine can be modified so that you can transmit at data rates from 60 to 9600 Baud for a 750-kHz clock rate and higher for 2-MHz and 4-MHz clock rates.

The conversion from one data transmission rate to another is easily accomplished with the aid of appropriate software time-delay subroutines that replace R-C time-constant circuits. An additional advantage that is gained from the use of software is the potential to perform code conversions. For example, 5-level Baudot KSR machines are in widespread use and can still be obtained for under \$50. It is not too difficult to develop software that converts ASCII to Baudot and thus produce an inexpensive hard-copy terminal for the laboratory scientist, engineer, ham or computer buff.

#### Receive subroutine

The software UART receive subroutine requires 50 instructions and will not be repeated here. (Copies of the transmit and receive subroutines and a description of the



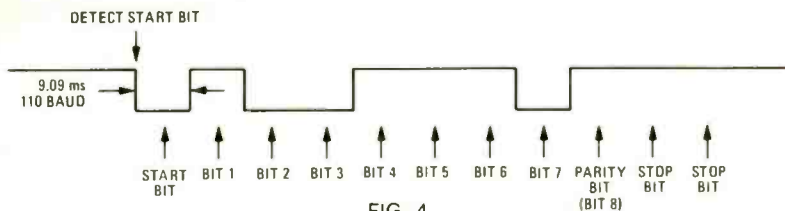

FIG. 4

smart data-entry station are available from Professor Paul Field, Department of Chemistry, Virginia Polytechnic Institute and State University, Blacksburg, VA 24061.) The basic programming concepts associated with the receive subroutine are shown in Fig. 4, which represents an 11-bit asynchronous serial ASCII word that is being detected by the 8080A-based microcomputer with the aid of the SN74126 three-state buffer gate shown in Fig. 1. The program repeatedly tests the serial ASCII input line for a logic 0 state. Once a logic 0 state is detected, which corresponds to a start bit, the program goes into a 4.54-ms wait loop. Upon leaving the wait loop, the program again inputs the logic 0 into bit position DO in the accumulator, thus testing the validity of the start bit. The start bit is rotated to the carry bit and the program then enters a 9.09-ms wait loop, after which it inputs Bit 1 into position DO in the accumulator. Register H is used as the SAVE register that stores the growing ASCII data word. The SAVE register is rotated one position, and the 9.09-ms wait loop is again entered, after which Bit 2 (a logic 0 in Fig. 4) is input into bit position DO in the accumulator. The input of successive data and parity bits continues until the entire 8-bit data word is entered into the SAVE register. The two stop bits are also detected. With appropriate modifications, the program can detect parity or framing errors or an overrun condition. A data-ready flag signal can also be generated from software with the aid of a second SN7474 latch.

#### TIMESHARE

continued from page 67

able A and the second value to B. Line 20 assigns to variable C the value of the square root of the sum of the two entered values to the third power. Line 30 outputs the value of C to the terminal. Line 40 transfers execution back to line 10, and you're ready to execute the program for two new values.

When you have all the results you require, you push the ESC key (escape) to stop the program, then sign off or enter a new program.

Notice the similarity between BASIC and English:

- INPUT—to input a value for a variable
- LET—to let a variable equal a value
- PRINT—to print the results at the terminal
- GOTO—to go to another part of the program.

This similarity exists throughout the BASIC language, which makes it ideal for people who are not computer programmers but need or desire to use a computer.

R-E

#### Applications

The above software UART routines were used in a "smart" remote data-entry station that was tied via a 20 mA current-loop to a PDP 8/L minicomputer in a physical chemistry laboratory. The data entry station intercepted the 20-mA teletype current-loop tied to the minicomputer. The remote data-entry station permitted students to load data into memory and then transmit it as a block to the minicomputer, which analyzed the data and provided a print-out. With the 20-mA current loop operating in the full duplex mode, ten or more remote data-entry stations could be tied to the minicomputer.

This column provides a good demonstration of the software-hardware tradeoffs that can be accomplished using microcomputers. Similar, and perhaps more comprehensive, routines have already been written for all of the popular microprocessor chips, such as the 16-bit PACE or the 8-bit 6800. The faster and less expensive that microcomputers become, the more likely that all moderate speed digital functions will be executed via software. The theme of software replacing hardware is an important one, and we will return to it many times in future columns.

R-E

#### 8,192 x 8 BIT STATIC MEMORY

EXCEPTIONALLY LOW POWER

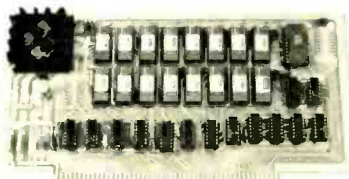

KIT \$295<sup>00</sup>

- ★ ALTAIR 8800 / IMSAI 8080 BUS COMPATIBLE
- ★ FAST 215 nS—FULL SPEED—FOR Z80 ALSO
- ★ EXCEPTIONALLY LOW POWER—LESS HEAT
- ★ LESS THAN OTHER "LOW POWER" MEMORY
- ★ BATTERY STAND-BY CAPABILITY
- ★ ALL SIGNALS TO MOS DEVICES BUFFERED

PROTOTYPING BOARD

Z80-CPU

CARD RACK

16K RAM

2K ROM/2K RAM

LOW PROFILE IC SOCKETS

EDGE CONNECTORS

DB25 CONNECTORS

SHIPPING EXTRA, ADD \$2.00

NJ RES. ADD 5% SALES TAX

ELECTRONIC CONTROL TECHNOLOGY

P.O. Box 6, Union, New Jersey 07083

CIRCLE 67 ON FREE INFORMATION CARD

## Fast, Fool-proof TV Alignment



### B&K-PRECIS ON SWEEP/MARKER GENERATOR

Model 415, \$485

With the B&K-PRECISION Model 415 you can complete a TV alignment in about the time you would spend hooking up the instruments for conventional alignment procedures. It's ideal for testing adjacent channel interference in CATV installations, too.

Everything you need is built into the Model 415—sweep and marker generators, a marker adder and three bias supplies. The 10 crystal-controlled IF markers can be shown either vertically or horizontally on your scope, and they light up on the front panel IF response and chroma bandpass diagrams as you use them.

Proper set alignment is assured and is almost automatic when you follow the Model 415's programmed alignment procedures.

Contact your local B&K-PRECISION distributor for a demonstration, or write for detailed information on how the Model 415 can save you time and increase your profits.

**B&K PRECISION**  
PRODUCTS OF DYNASCAN

6460 West Cortland Avenue  
Chicago, Illinois 60635 • 312/889-9087  
In Canada: Atlas Electronics, Ontario

CIRCLE 79 ON FREE INFORMATION CARD

## THE MEAN LITTLE KIT

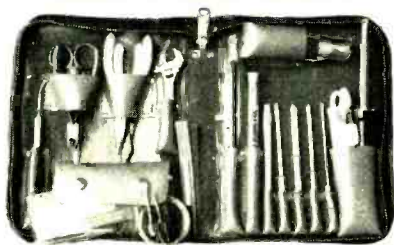

New compact 24-piece kit of electronic tools for engineers, scientists, technicians, students, executives. Includes 7 sizes screwdrivers, adjustable wrench, 2 pair pliers, wire stripper, knife, 2 alignment tools, stainless rule, hex-key set, scissors, 2 flexible files, burnisher, miniature soldering iron, solder aid, coil of solder and desoldering braid. Highest quality padded zipper case, 6 x 9 x 1 3/4" inside. Satisfaction guaranteed. Send check, company purchase order or charge BankAmericard or Mastercharge. We pay the shipping charges.

JTK-6 TOOL KIT ..... \$60.00

### FREE CATALOG

128 pages of hard-to-find precision tools. Also contains 10 pages of useful "Tool Tips" to aid in tool selection. Send for your free copy today!



**JENSEN TOOLS and ALLOYS**  
4117 N. 44TH STREET, PHOENIX, ARIZONA 85018

CIRCLE 23 ON FREE INFORMATION CARD

# equipment reports

## Heath AS-1344 2-Way Column Speaker System Kit



CIRCLE 50 ON FREE INFORMATION CARD

THESE ARE THE NEWEST SPEAKERS IN THE Heathkit line. I was fortunate to get two units out of early production. They are 40 inches tall and 11 inches square which lets them fit easily into almost any room. And the small size is especially important if you need four systems for quadriphonic sound. They are also tall enough so that the speakers themselves, which are physically located in the top half of the cabinet, extend above any low-level obstructions such as coffee tables, lamps and the like that are common to the modern American home.

Each enclosure contains four speakers: two 6-1/2-inch woofers and two 1-inch dome tweeters. The woofers handle 30 watts continuous, the tweeters, 20 watts continuous. Woofers and tweeters are fused separately (in pairs).

This system is truly a one evening project. All that has to be done is to assemble the crossover network and install the speakers. The cabinet itself is fully assembled and finished. It requires no work at all.

The diagram in Fig. 1 shows the schematic

# TIGER .01

Introduced three years ago, our "Tiger .01" is still one of the finest amplifiers available in its power class. This amplifier introduced our 100% complementary circuit which has become a standard feature in many of the better amplifiers. This combined with an output triple produces a circuit that can honestly be rated as having less than .01% IM distortion at any level up to 60 Watts. Relatively low open loop gain and a conservative amount of negative feedback results in clean overload characteristics and good TIM characteristics.

Other features are volt-amp output limiting, plus three fuses and an overheat thermostat. Despite the "budget" price an output meter is standard equipment. Each channel measures 4 1/4 x 5 x 14. Four will mount in a standard width relay rack for four channel systems.

### SPECIFICATIONS

60 Watts—4.0 or 8.0 Ohm load Minimum RMS from 20 Hz to 20 KHz with less than .05% Total Harmonic Distortion.

IM Distortion ..... less than .01%  
Damping Factor ..... 50 or greater 20 Hz to 20,000 Hz.  
Hum and Noise ..... -90 dB

# 207/B Amplifier (single channel) ..... \$110.00 Ppd  
# 207/B Amplifier — Kit ..... \$ 77.50 Ppd

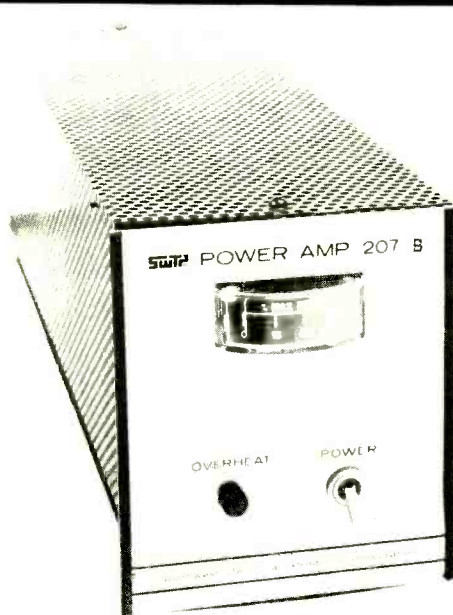

Southwest Technical Products Corp.  
219 W. Rhapsody, Dept. FM  
San Antonio, Texas 78216

CIRCLE 63 ON FREE INFORMATION CARD



of the crossover. The audio signal is coupled to the speaker system through the input terminals. This signal goes directly to the woofers (SPKR 1 and SPKR 2) through fuse F1 and to the tweeter circuit (C1, R1, L1, etc.).

The woofers operate as full-range speakers, covering 35 Hz to 10 kHz. However, above 4 kHz, they no longer maintain good dispersion and the off-axis sound output begins to diminish. This smooth response allows the

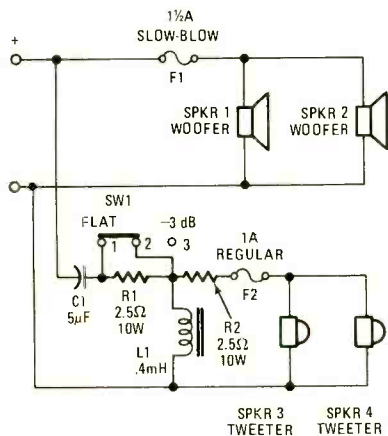

FIG 1

woofers to be operated with no electrical crossover. Fuse F1 protects the woofers against input overload.

The tweeter circuit consists of a high-pass second order filter, level switch S1, and two dome tweeters (SPKR 3 and SPKR 4). The audio frequency choke L1 and capacitor C1 form a high-pass filter while resistor R2 is a series attenuator. Resistor R1 and switch S1 provide 3-dB of attenuation when S1 is in the -3-dB position. Fuse F2 protects the tweeters against overload.

Because of its design, two radiating sides on each enclosure, some variations in speaker position and placement are feasible. These are shown in Figs. 2, 3, 4 and 5. To summarize, the placement of the speakers depends on the acoustic balance of the room and your personal preference in frequency balance. In a soft room (thick carpet, heavy drapes, soft upholstered furniture, etc.) place the level switch in the flat position with the speaker system positioned as shown in Fig. 2. The

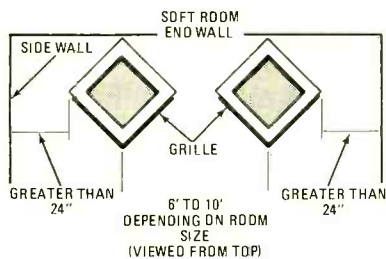

FIG 2

listener should be about as far away from the speakers as the speakers are apart.

In a hard room (no carpet, thin or no drapes, hard surfaced furniture) place the level switch in the -3-dB position and set up the speakers as shown in Fig. 3. The listener should be about as far away from the speakers as the speakers are apart.

Most rooms are a combination of soft and hard. If you have one of these average rooms, experiment with the previously mentioned speaker positions and settings of the level switch to find the combination that provides

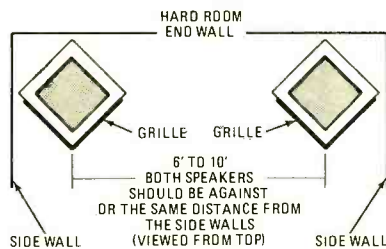

FIG 3

the best balance over the entire listening range.

The speaker system also offers many options as to the amount of direct versus reflected sound. These options, shown in Figs. 4 and 5, are especially useful in narrow rooms or wide rooms where irregular furniture placement is used. Where a wall is used as a reflecting surface, the wall should be smooth and hard.

We found the speakers lived up to their specs: providing a flat energy output from 50 Hz to above 12 kHz with a dispersion of 270° (again, as stated in the manual, on-axis response goes beyond 20 kHz). The system is rated at 4 ohms and never falls below this rating at any frequency.

The cabinet design is an acoustic suspen-

**SPECIAL OFFER!**

**Buy 23-channel CB now. Get new 40-channel later at 1/2 price!**

UPON FCC TYPE ACCEPTANCE

**"Don't be without CB while waitin' for the FCC"**

NO MODIFICATION FEES—NO MODIFICATION DELAYS—OWN AND KEEP TWO UNITS

**handic**<sup>®</sup>

handic USA, Inc. 14560 NW 60th Ave. Miami Lakes, FL 33014

**THE ORANGE EQUIPMENT KNOWN FOR PROFESSIONAL QUALITY THE WORLD OVER**

CIRCLE 27 ON FREE INFORMATION CARD

sion type which has, of course, one limitation: it requires a relatively high-power amplifier. For normal operation a minimum

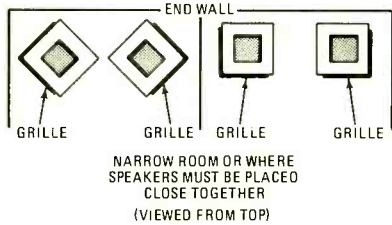

FIG 4

of 5 watts per channel is recommended. However, for a robust listening level you will need 15 to 25 watts per channel. Most of the

power is used in the low frequency range. This is the first place an amplifier will be overtaxed. If there is not enough power, you'll hear it as distorted sound, caused by clipping, on peaks in the music. If you use these speakers in a 15 by 20-foot room with an 8-foot ceiling (24,000 cu ft) and the room contains average furnishings, a peak power of 20 watts per channel into a pair of speakers will produce a sound field equivalent to 100 dB SPL (sound pressure level). This corresponds to the normal peak sound intensity produced by a large orchestra performing in a concert hall.

We connected the speaker system to our Heath Modulous control center and power amplifier. The response was amazingly good: clear, sharp and pleasant to listen to. Because of the height of the speakers above the floor we found it desirable to use the -3-dB

position on the switch to limit what we considered excessive high frequency response. Since we have installed the speakers

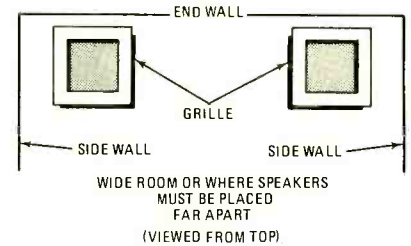

FIG 5

several other people have listened to them and they seem to feel that it sounds better with the switch in the normal position. Perhaps our ears are tainted by prior listening habits. Assembly is really a cinch. The units sound great, look great, fit into almost any decor and are a worthwhile addition to any hi-fi system. **R-E**

## Sencore DVM-35 And DVM-36 Digital Multimeters



CIRCLE 80 ON FREE INFORMATION CARD

THE SENCORE PEOPLE ARE REALLY GOING DIGITAL in a big way. They now have a "set" of digital multimeters for all purposes. There are four models in all. The two in the middle are the *DVM-35* and *DVM-36*. They look enough alike to be twins; both are built in the same portable compact cases made of Cycloc plastic. They say these can be dropped 10 feet to a cement floor without damage. I didn't have the intestinal fortitude to try this, but they look tough!

Despite the similarity, there are differences. The *DVM-35* has a 3-digit readout with 1% full-scale accuracy; Voltage scale are 1, 10, 100, 1000 on AC or DC. For current, 1, 10, 100 and 1000 mA, again both AC and DC. The ability to read alternating current is one

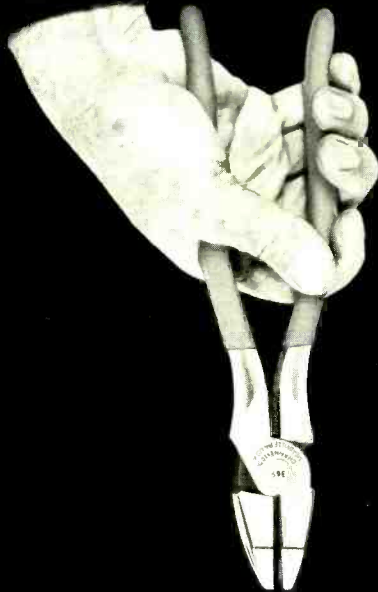

## More Power To You!

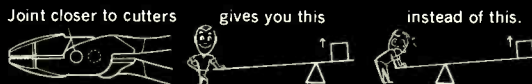

More cutting power with less effort. The plier provides the "extra muscle." Perfectly mated cutters HOLD their edge. They're hand honed, scientifically heat treated. The joint is smooth working as a Swiss watch. Interfaces are precision machined. Drop forged, top quality steel. Beautiful full polished finish. Blue dipped plastic grips optional. Quality in every detail (at no premium in cost). CHANNEL-LOCK No. 369 Hi-Leverage Plier. Ask for it by name.

# CHANNEL LOCK

No. 369 Hi-Leverage Plier—9 Inch

Meet The Rest Of The Family . . . Send For Our Free Catalog

CIRCLE 16 ON FREE INFORMATION CARD



of the handy things in the newer DVM's. On all ranges, if the reading is greater than full-scale, overrange is indicated by the display showing all "8's", and blinking.

For resistance readings, the DVM-35 has a total of six. The lower three, 100, 1000 and 10K are low-power scales with only 0.2 volt impressed across the circuit-under-test. This won't turn on even a germanium transistor. The high scales are 100K, 1000K and 10 megohm, and 1.0 volt is applied to the circuit. So, these can be used for the old faithful in-circuit ohmmeter tests of transistor junctions. You will see a high reading one way and a low the other. For the high reading, the only difference you'll see will be the "infinity" display. Since this is actually an overrange condition to a DVM, the display blinks "888" at you.

The "other brother", the DVM-36 is in the same case. It has a 3½ digit readout and different ranges. Voltage is 2, 20, 200 and 2000 volts both AC and DC. The same basic ranges are used for currents, both alternating and direct. In the DVM-36, the accuracy is 0.5% of full-scale on all voltage and current ranges. Resistance ranges read to an accuracy of 1% of full-scale ± 2 digits. The Ohms ranges use "2's": 200, 2K, 20K, all low-power with 200-mV applied, and 200K, 2000K and 20 megohm on the high power ranges, with 2.0 volts applied across the circuits.

The controls are simple: the range and function switch is very plainly marked. A selector switch on the lower right corner of the panel changes it from AC to DC volts. The on/off switch is on the left and in the middle is a zero-adjust knob. To set this up,

set the selector on DC volts, any range, short the prods and adjust the zero-adjust until the display reads "000" (on both models). You don't have to reverse prods for voltage or current readings. Polarity is automatic: if the voltage is negative, a minus sign lights up. It also lights up on DC current readings, which saves you from the old problem of hooking milliammeters up backward!

Speaking of probes—both of the instruments use the same type, and it has some really handy features. The body of the probe is triangular and it has a guard-ring to keep unwary digits (yours, not on the readout!) from getting into hot stuff. A long, thin red-tip has a very sharp point for making good contact. If you don't believe it's sharp, drop it on your knee.

On one side of the probe, at the front, are two small flush pushbuttons. One of these is marked PUSH-ON. This is a switch, in parallel with the panel switch. You can leave the instrument turned off until you're ready to take a reading. Just push the button, note the reading and let up. This can be a big help in saving the batteries. The other one is marked ISO DCvx2. Holding this down puts an extra 15-megohm resistor in series with the probe; this multiplies the full-scale range by a factor of two. For a 1000-volt scale, this would let you read 2,000 volts. The display reads *one-half* of the actual voltage: say this was 1500 volts. The readout would show "750" as long as the ISO button is held down.

Since this also brings the input impedance of the instrument from its normal 15-megohms up to 30 megohms, this feature can

*continued on page 100*



### Our whole family helped assemble this wonderful Schober Organ... and now we all play it!

Talk about real family fun! We all worked together for a few hours almost every day. Almost too soon, our Schober Organ was finished. Our keen-eyed daughter sorted resistors. Mom soldered transistor sockets, although I had never soldered anything before. And it did our hearts good to see the care with which our son—the only 12—installed the transistors. Me? I was the quality control inspector—they let me do the final wiring.

Our completed Schober Organ compares favorably with a "ready-made" one costing twice as much! (The five models range from \$650 to \$2850.)

Just send the coupon for the fascinating Schober color catalog (or enclose \$1 for a 12-inch LP record that lets you hear as well as see Schober quality).

**The Schober Organ Corp., Dept. RE-158**  
**43 West 61st Street, New York, N.Y. 10023**

Please send me Schober Organ Catalog.  
 Enclosed please find \$1.00 for 12-inch LP record of Schober Organ music.

NAME \_\_\_\_\_  
 ADDRESS \_\_\_\_\_  
 CITY \_\_\_\_\_ STATE \_\_\_\_\_ ZIP \_\_\_\_\_

**CIRCLE 33 ON FREE INFORMATION CARD**

# ONE RIG DOES IT ALL!

**33KV**

**Tube and Solid State**

**THE UNIVERSAL  
PJS-298**

**33KV LEADED GLASS 19" CRT**

EIA recommended to protect against dangerous X-radiation

**A MUST FOR  
TODAY'S  
SERVICING**

**ACCESSORIES INCLUDE:**

- CRT 90° Extension
- Yoke Extension
- Transverter
- Convergence Load
- Universal Yoke
- Convergence Assembly
- Blue Lateral Assembly
- Anode Extenders

**SOLD THROUGH DISTRIBUTORS ONLY**

PLEASE SEND ME MORE INFORMATION

NAME \_\_\_\_\_  
 ADDRESS \_\_\_\_\_  
 CITY \_\_\_\_\_ STATE \_\_\_\_\_ ZIP \_\_\_\_\_

**BUILT-IN SPEAKERS**

Easy audio checking

**40 KV METER**

50aU sensitivity monitor

**FRONT CONNECTORS**

Convenient cable plug-in

**OBSOLETE PROOF**

Plug in modules for up-dating

\$298.98 VALUE

**SPECIAL INTRODUCTORY OFFER**

**\$229.95**

COMPLETE WITH CRT

**TeleMatic**

2849 FULTON ST., BROOKLYN, NY 11207  
 PHONE: (212) 827-1500

**CIRCLE 6 ON FREE INFORMATION CARD**

# HOW TO SAVE HUNDREDS OF DOLLARS ON PARTS. PAINLESSLY.

At CSC, we've developed a family of ingenious Design Mate™ test equipment that gives you professional quality and precision at very *un*professional prices. Each unit can save you money—and time—in a number of interesting ways.

For more information on these, or any other CSC products, see your dealer or write for our catalog and distributor list.



## SAVE MONEY AND TIME WITH DESIGN MATE 1

This precision all-in-one unit combines a solderless plug-in breadboarding system with a built-in better-than-1%-regulated variable 5-15V supply and 0-15V voltmeter. Gives you everything you need to design and test circuits faster than you ever could before. Saves money by eliminating lead damage and heat damage to components. Lets you re-use parts over and over again, to save even more. All for just \$54.95\*.



## STRETCH YOUR BUDGET FURTHER WITH DESIGN MATE 2

Precision function generator lets you test all kinds of equipment, with 1Hz-100kHz signals. Low-distortion sine waves, high-linearity triangle waves, fast-rise-time square waves. Five decade ranges, accurate to 5% of dial setting, with variable 100mV-10V P-P output and constant 600-ohm impedance. At \$69.95\*, it's a lot of signal for very little money.



## SAVE MORE MONEY AND TIME WITH DESIGN MATE 3

Accurate R/C bridge helps you use "bargain" components. Quickly and easily measures resistance 10 ohms—10 meg; capacitance 10pF-1μF—both in decade ranges to within 5% of dial setting. Simple, 2-control operation and positive LED indication make measurements in seconds. At \$59.95\*, it pays for itself in no time.

CONTINENTAL SPECIALTIES CORPORATION



EASY DOES IT

44 Kendall Street, Box 1942  
New Haven, CT 06509 • 203-624-3103 TWX: 710-465-1227  
West Coast office: Box 7809, San Francisco, CA  
94119 • 415-421-8872 TWX: 910-372-7992



# BUILD



## Portable Mini Organ

*Play music anywhere with this self-contained battery-powered mini-organ. It has its own keyboard, speaker, unique pitch-bender and covers a five octave range*

A TOP-OCTAVE DIVIDER WORKS LIKE THIS: You pump a high-frequency clock signal into one of the pins and like magic a full octave of equally tempered musical notes come flowing out of the rest of the pins. As you might expect, this is extraordinarily useful for organ-type musical instruments.

In various single or multiple package configurations, they've been around for years. When they were first developed the price was high enough to effectively limit their application to large, expensive instruments. Now, we're getting out on the "learning curve" and while these devices are still not cheap, they are inexpensive enough to become candidates for some "small" applications.

Like, for instance, here's OZ. It's battery-powered and has a built-in amplifier, speaker and keyboard. You can take it anywhere; into the woods,

**JOHN S. SIMONTON, JR.**

your van, to the beach—places you wouldn't ordinarily expect to find a keyboard instrument. For the musician on the road, it's great for getting your chops down on long bus rides. And as an added benefit, a guitar or other instrument can plug in and share OZ's amplifier. For music students, it's a practice instrument that will fit into the most confining dorm room, apartment or budget.

It's polytonic—which means that you can play notes, intervals or full chords—and its output level is appropriate for most electronic music synthesizers. Yes, it works quite well with the Gnome (*Radio-Electronics*, Nov., Dec. 1975 and Jan. 1976 issues.) To make interfacing easy, OZ features a trigger output that is switch selectable to be either high as

long as any key is down, or a short pulse every time a key is depressed.

It has a really slick touch-operated pitch bender that glissandos, vibrates and trills single notes or whole chords up to a full octave. The harder you press, the more the frequency changes.

### Let's see how it works

The top-octave IC is the real guts of OZ; but, before we look there, we must start with the thing that makes it all go—the clock.

Two CMOS NOR gates (IC6-a and IC6-b, Fig. 1) are configured in a classical astable circuit in which timing capacitor C20 charges and discharges through resistor R42 and the variable TUNE control R57. The nominal frequency of the clock is 500 kHz and is adjustable with the tuning control through an octave range.

## PARTS LIST

All resistors 1/2 watt, 10%.

R1-R18—330,000 ohms  
 R19-R36, R51, R53, R54—22,000 ohms  
 R37—33,000 ohms  
 R38—3.9 megohm  
 R39—150,000 ohms  
 R40, R41, R56, R60—10,000 ohms  
 R42—2700 ohms  
 R43—680,000 ohms  
 R44—100,000 ohms  
 R45, R46, R47—10 ohms  
 R48, R52, R55—2200 ohms  
 R49—4700 ohms  
 R50—1000 ohms  
 R57, R58, R59—5000-ohm potentiometers  
 C1-C18, C24—.005  $\mu$ F, ceramic disc  
 C19, C22, C26, C31—.05  $\mu$ F  
 C20—47 pF  
 C21, C28, C29, C30—.01  $\mu$ F

C23—100 pF  
 C25, C32—1  $\mu$ F, 12-volt electrolytic  
 C27—250  $\mu$ F, 12 V  
 C33—0.22  $\mu$ F, Mylar  
 D1—1N914 diode  
 IC1, IC2, IC3—CD4013  
 IC4—MK-50240  
 IC5—CD4024  
 IC6—CD4001  
 IC7—LM380  
 J1—miniature open circuit phone jack  
 J2—miniature closed circuit phone jack  
 J3—pin jack  
 LED's (6)—MSL-7-50 light-emitting diode  
 Q1, Q2—2N5129 or 2N3904 transistor  
 S1, S3—SPST slide switch  
 S2—2P5T rotary switch  
 Keyboard—18-note DPST switching  
 Miscellaneous hardware, 4 knobs,  
 front panel, vinyl covered case, 8-

ohm speaker, speaker bezel, grille cloth, two 5-lug terminal strips, wire, plastic tubing, coaxial cable, bare wire, cable clamps, wire ties, printed circuit board, LED circuit board, pitch-bender circuit board.

**A complete kit of parts to build OZ, including case, PC boards, keyboard, etc, less batteries, is available from;**

**PAIA Electronics, Inc.**

**P. O. Box 14359**

**Oklahoma City, OK 73114**

**for \$84.95 plus shipping and insurance for 12 lbs. Order No. 3760**

**A set of three circuit boards may be obtained for \$10.00 postpaid. Order No. 3760 PC.**

**The keyboard is available for \$39.00 including postage and handling. Order No. AGO-18.**

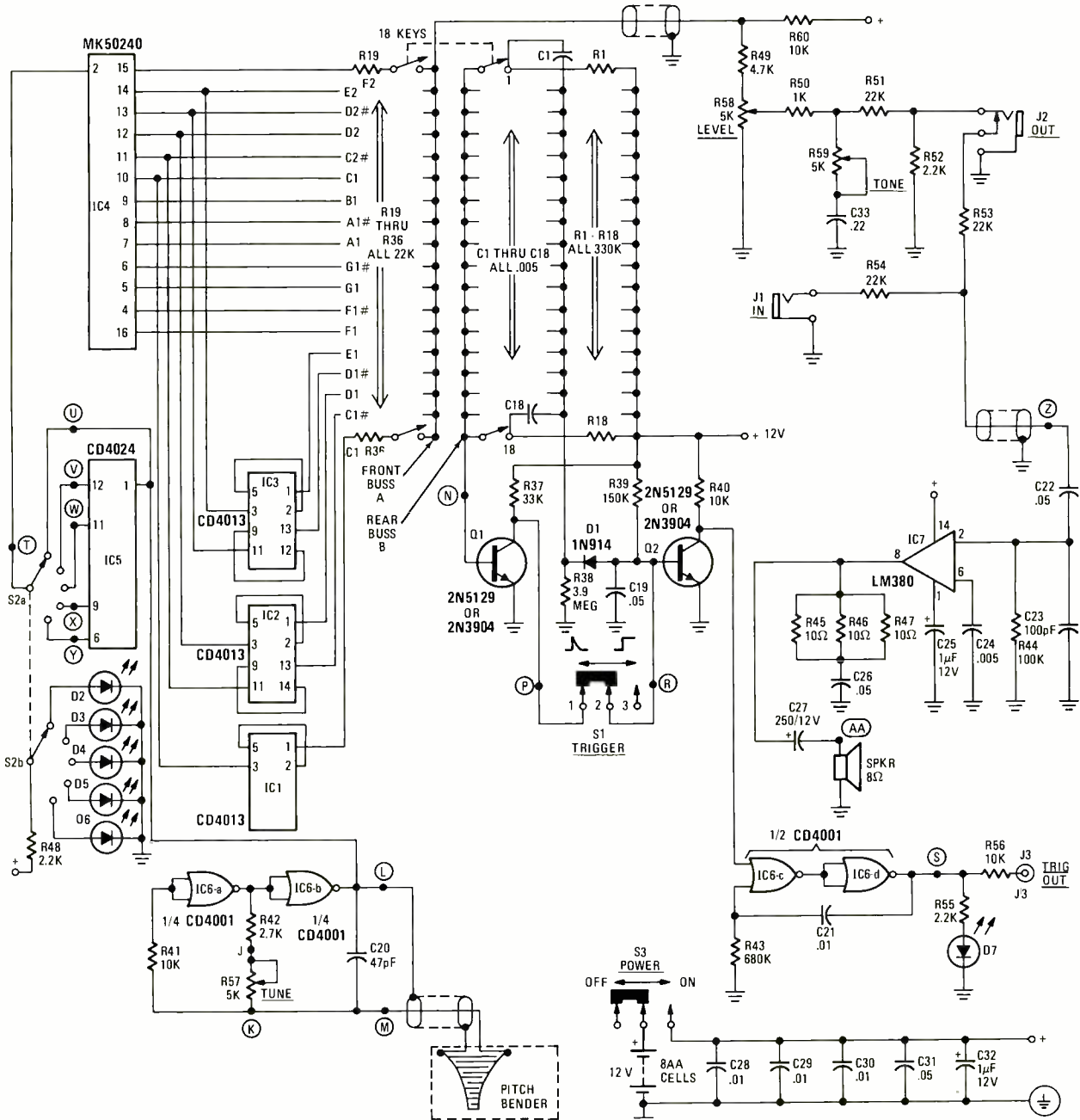

FIG. 1—COMPLETE SCHEMATIC, OZ MINI-ORGAN AND POLYTONIC PITCH SOURCE FOR MUSIC SYNTHESIZERS.



The frequency of this type of astable may also be changed by changing the value of capacitor C20. We don't want to use this as a tuning control for the oscillator, simply because variable capacitors are more expensive than potentiometers.

Wired across the timing capacitor we have a strange looking symbol labeled "pitch bender". This is a small circuit board etched as shown in Fig. 2 and as

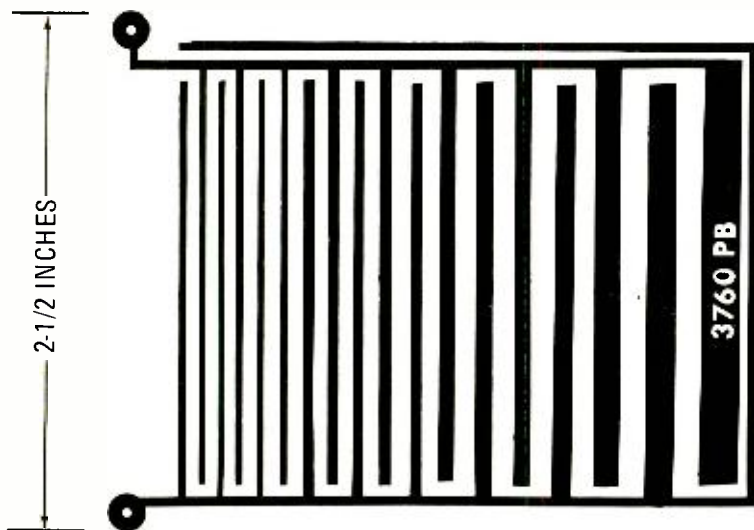

FIG. 2—PITCH BENDER PCB SHOWN FULL-SIZE.

you can see, it consists of an interlaced grid of conductors.

### Bending the pitch

This circuit board is a capacitor; but, unlike most capacitors, it is *designed* to be touch sensitive. In actual use, the conductors of the board are insulated by a thin film of paint so that resistance effects are eliminated.

When there is nothing touching the surface of the plate, its equivalent capacitance is low—a few pF. But when your hand touches the plate, the capacitance increases—your flesh has a higher dielectric constant than the air it is displacing. Pressing harder puts your hand in more intimate contact with the plate, which further increases the capacitance. Increased capacitance produces lower clock frequencies, which in turn lowers the pitch of the notes produced by the top-octave divider.

The five-position rotary switch S2 is a RANGE switch that transposes the OZ keyboard up and down in pitch by exact octave increments. This could have been done by switching resistors or capacitors in the clock, but by far the easiest and most precise way is to apply the clock to a divider chain and then select the divider-chain output that will serve as a clock signal for the top-octave divider. It is probably not necessary to say, but this works because the output of each successive stage in a bistable divider chain is exactly half the frequency of the preceding stage and in the equally

tempered musical scale, a frequency division of one half represents exactly an octave. The divider circuit is a type 4024 CMOS package. Notice that although there are seven stages of division on the IC, we only use four of them. (The fifth position of S2 is a direct connection between the clock circuit and the top-octave IC.)

The second section of S2 is used simply to light front panel LED's that

indicate the setting of the RANGE switch (superfluous, perhaps; but mighty handy on a darkened stage.)

Finally, the clock signal gets to where it does some good, the MK50240 top-octave divider that, in gratitude for being supplied with this elegant square-wave clock signal, produces for us a full octave (plus one note) of equally tempered scale.

But wait; here we have 13 notes—but there are 18 keys on the keyboard. If all those keys are going to produce notes we need to find another five semi-tones somewhere. We get these in essentially the same way that we came up with the range switch; that is, by dividing a note that we already have by 2 to get the same note in the next lowest octave. This is the task of the three 4013 dual type D flip-flops, IC1–IC3.

Key switching in OZ is certainly not elegant, but taking into account where we're headed (a pitch source for synthesizers that can be used as a stand-alone practice instrument) it is certainly cost-effective. When a key switch closes, it simply connects the note that the key represents to the common audio bus.

Notice a couple of things here. First, resistors R19–R36 are in essence mixing resistors; they prevent interaction between the outputs of the MK50240. Secondly, because of R49, R58 and R60, the audio bus that all these notes connect to is displaced from ground by a voltage equivalent to half the supply voltage. There's a reason for this. The

outputs of the top-octave IC are square-waves. If we switch the square waves to an audio bus that is at ground potential, not only is the squarewave (note) going to appear on the bus, but also the average value of the squarewave (half of supply). The average value is a DC level shift as far as the audio bus is concerned and it will ultimately appear in the output as a horrendous "thump" every time a key goes down. It's the *transition* that we hear and by closing to an audio bus that is already half the supply voltage, we eliminate the transition.

We're almost in a position to produce music, but before we do, we need some controls. For example, R58, which allows for varying the level of the signal that will eventually be applied to the amplifier or synthesizer. We also need some control over the harmonic content of those squarewaves coming on to the audio bus. The low-pass T-filter, consisting of R50, R51, R59 (the TONE control) and capacitor C33, does this for us.

If we're always going to use OZ with its internal amplifier and speaker we're home free because the next place the signal goes to is the LM380 amplifier (IC7) that drives the speaker.

But we might not always use CZ like that, so we need a few more goodies. J1 is wired as a mixing input to IC7 for play-along situations or interfacing to other musical gear, and J2 is a closed-circuit phone jack wired to disconnect the OZ pitch source from its internal amplifier when a plug is inserted. If you're going out to external processing gear, you obviously don't want to hear anything until after the processing.

### What type of trigger?

Synthesizers like to have some kind of triggering signal to let them know when to do things and (because it's the most useful way) these triggers usually reflect the keyboard activity.

Two types of triggers are particularly useful. We will look at a step trigger first because it's the easiest. When a key is pressed, a second set of switch contacts closes just after the audio switches close. As you can see from the schematic each of these contacts connects to the positive supply line through a resistor (R1–R18), with the other contact of each switch bussed to the other contact of all the other switches; all of which then connect to the base of Q1. If all the keys are up, Q1 is not conducting and its collector voltage is high.

Assuming that switch S1 is closed (which it must be for us to get step triggers) Q2 is being held on by the current flow through R37, producing a low output voltage at Q2's collector. After passing through the two inversions represented by the NOR gates IC6-c and IC6-d, the voltage is still low and this is what appears at the trigger output

jack J3: nothing. But when a key goes down, things change. Q1 turns on, which turns Q2 off, producing a high collector-voltage that passes through the two NOR gates and appears at trigger output jack TRIG OUT as a voltage. This trigger voltage will remain high as long as *any* of the keys are down and will not return to a low state until *all* the keys have been released.

The second useful type of trigger is one that goes high only momentarily each time a key goes down (whether other keys are already down or not). This is ordinarily called a pulse trigger and OZ generates it like this: For pulse triggers, S1 is open. Also, notice that as long as keys are up, capacitors C1 through C18 are charged essentially to the supply voltage through their respective resistors, R1-R18, and the common resistor R38. The charge on these capacitors is such that the end connected to the switch contact is positive with respect to ground.

When a key switch closes (let's take the first one as typical), the end of C1 that was positive is connected to ground through the base-emitter junction of Q1 (Q1 turns on; but with S1 open, Q1 doesn't connect to anything so we really don't care). When this happens, the other (more negative) end of C1 forces the junction of D1 and R38 below ground potential. C1 immediately begins to charge through Q1 and R38, and as it does, it momentarily turns Q1 off. The result—a short positive-going spike at the collector of Q1. Notice that other keys can now close and their associated capacitors will have identically the same effect that C1 did. Q1's collector will respond with a short positive-spike each time.

This spike isn't really quite long enough and modifying this portion of the circuitry to make it longer, would cost us noise immunity—the trigger circuit would begin responding to the “chatter” that goes along with any switch closure (particularly switches of the kind you find on organ-type keyboards). To make the spike longer, we build a pulse stretcher from IC6-c and IC6-d. The output of the pulse stretcher becomes the actual trigger output. The LED is there to indicate to the user that he is getting a trigger and R55 serves as a current limiter for this LED. R56 is simply an isolating resistor.

### Construction

A complete kit is available, which gets the monkey off your back as far as gathering together all the bits and pieces (case and keyboard, for example) is concerned. Circuit boards are available separately or if you're used to etching your own, you can duplicate the layout shown in Fig. 3. If you prefer perf-board construction, that's fine, providing you

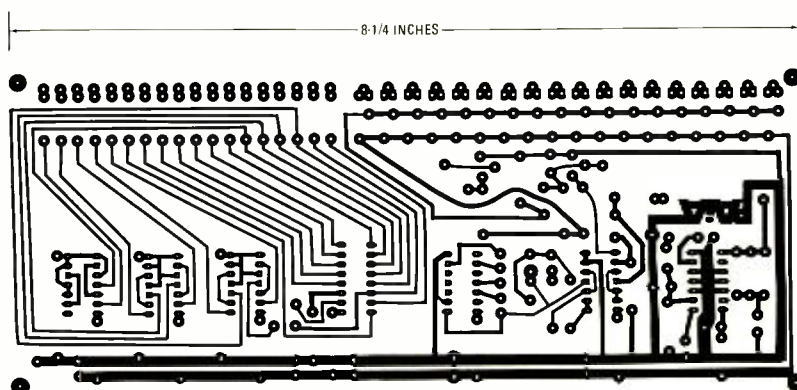

FIG. 3—OZ PRINTED CIRCUIT BOARD SHOWN HALF-SIZE.

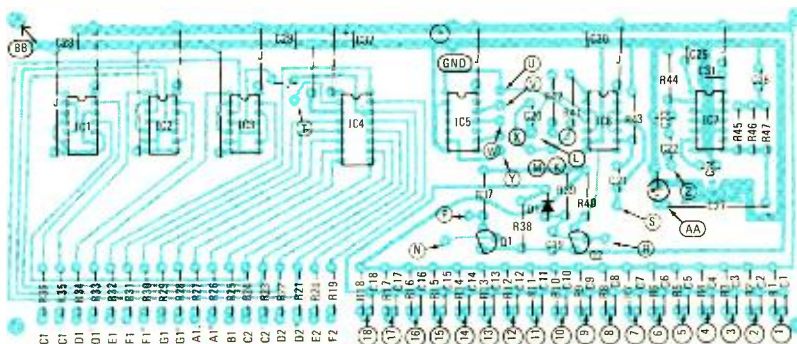

FIG. 4—PC BOARD, PARTS LAYOUT.

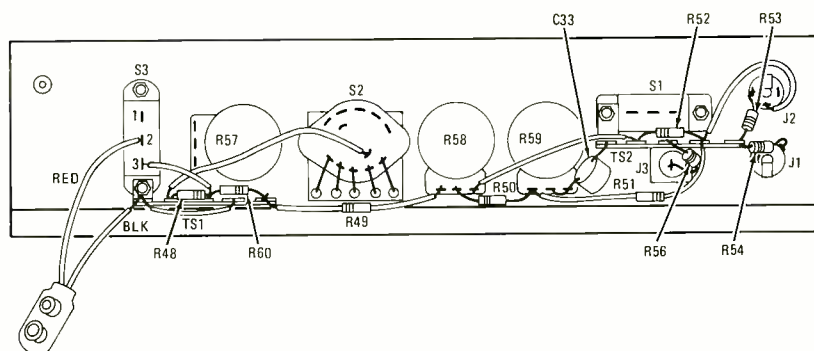

FIG. 5—PARTS MOUNTED AND WIRED entirely on the front panel.

bear in mind the warnings that will follow shortly. But first let me bring something important to your attention.

OZ is one of those devices that could very easily be built with fifty million wires running back and forth between the circuit board, keyboard and control panel. You're going to come up with a lot of wires anyway, but you will notice that in the model illustrated, some parts are on the circuit board (Fig. 4) while others are mounted on terminal strips on the front panel itself. (See Figs. 5 and 6.) This was done to minimize the wire count and I highly recommend that you study the drawings and photos and stick to their precedents as much as possible.

I recommend the following assembly sequence: First, build up the circuit board. All the standard warnings apply here. Watch the polarity of electrolytic capacitors and the orientation of IC's, diodes and transistors: don't heat the parts to the point that they glow cherry

red, etc. An additional thing that you have to worry about is the fact that you're working with CMOS IC's, so you'll want to be careful about accumulated static charges.

With the circuit board assembled, the wires connecting it to the keyboard can be installed. A tip: leave yourself enough length on these wires so that you can have access to the circuit board in case something isn't quite right. But don't make them so long that you are guaranteed to have radiation problems.

Next, wire the front panel (Fig. 5). Note the components that are mounted here rather than on the circuit board. Notice that LED's 1 through 5 are mounted on a small circuit board secured by the shaft of the rotary switch S2. LED 6 is supported by its leads and those of R55. This is not the best way to do the job, but it was the only practical thing we could come up with.

*to be continued*



# BUILD

## Digital Clock For Your Car

*Part I—Preliminary details on a useful automotive accessory that is rarely available as original equipment. A valuable aid for the trucker and road rally enthusiast that is simple and easy to build.*

ROBERT C. ARP\*

THE AUTOMOTIVE INDUSTRY HAS NEVER PROVIDED its customers with the one device to which the economy of the whole world is geared: a clock that keeps time. It would seem, therefore, that this is a natural area for semiconductor manufacturers to exploit.

Until now, the products with which these manufacturers have challenged that need have not been accepted. The complaints from consumers are:

1. The required crystals for an accurate automotive clock are expensive and hard to get.
2. Frequency adjustments to the oscillator require an accurate time interval or frequency counter.
3. Available MOS integrated-circuit clocks designed for vehicular use do not interface directly with low-voltage, dual-in-line displays.
4. Of the displays with which these clocks do interface, LED displays are difficult to read in sunlight, liquid-crystal displays cannot be read in the dark and gas-discharge displays require a high-voltage supply.
5. Display intensity control is not automatic.

\* Product Engineer, National Semiconductor Corp.

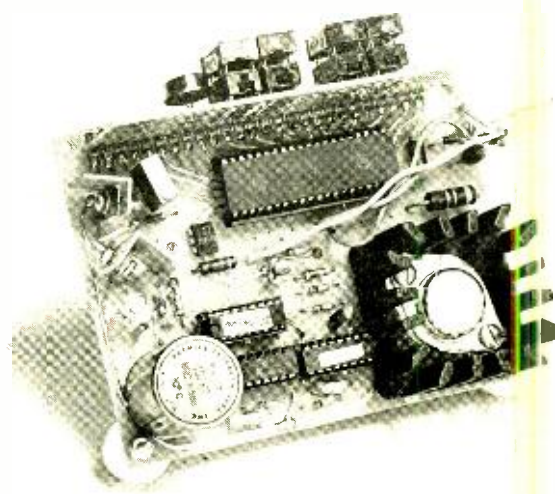
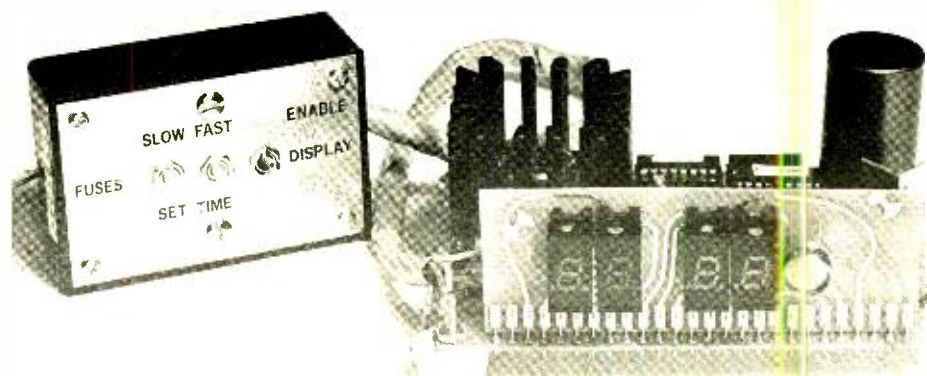

There are also several additional areas of concern. These include:

1. Battery current drain.
2. Physical orientation of displays.
3. Radio interference.
4. Physical size of the finished product.
5. Protection to vehicular wiring.
6. Accuracy.

The introduction of two new products, the MM5385 digital clock and the MM74C928 3½-digit counter, by National Semiconductor Corporation, 2900 Semiconductor Drive, Santa Clara, CA 95051, is the basis for an automotive digital clock with:

1. A crystal-controlled oscillator using a standard 100-kHz crystal. The oscillator may be adjusted without a time-interval or frequency counter.
2. Automatic control of display intensity using a photoresistor.
3. Direct interfacing with 7-segment LED and incandescent displays. The two types of displays are directly interchangeable, using appropriate display boards.
4. Very low power-supply current when ignition switch is off and displays are inhibited.
5. No radio interference.
6. Divide by 2,000 with a single IC to produce the 50-Hz input to

the clock IC.

7. Only three CMOS integrated circuits in addition to the clock IC are necessary.
8. The power supply to fully protect the vehicle and the clock circuitry.
9. Operation with vehicular supplies from 6 to 18 volts.

### How it works

Figure 1 shows the schematic diagram of the Automotive Digital Clock. Protection of the automobile wiring and the battery from shorts in the clock, as well as protection for the clock from reverse-polarity damage, is provided by the F1-D1 combination and F2. If the input voltage to the clock is reversed in polarity, D1 will be forward-biased and F1 will blow very rapidly. The Zener diode, D2, protects the clock from voltage transients or the application of voltage from an incorrectly adjusted voltage regulator or battery charger.

The negative side of the vehicle's battery is used as  $V_{DD}$ ; the positive side is common ( $V_{SS}$  and  $V_{CC}$ ) between  $-5V$  and  $V_{DD}$ . When the ignition switch is on, the optoisolator/coupler enables the display. Voltage regulator IC1 provides a stepdown in absolute value from  $V_{DD}$  to 5 volts. Capacitor C2 is required for regulator stability; it cannot be omitted.

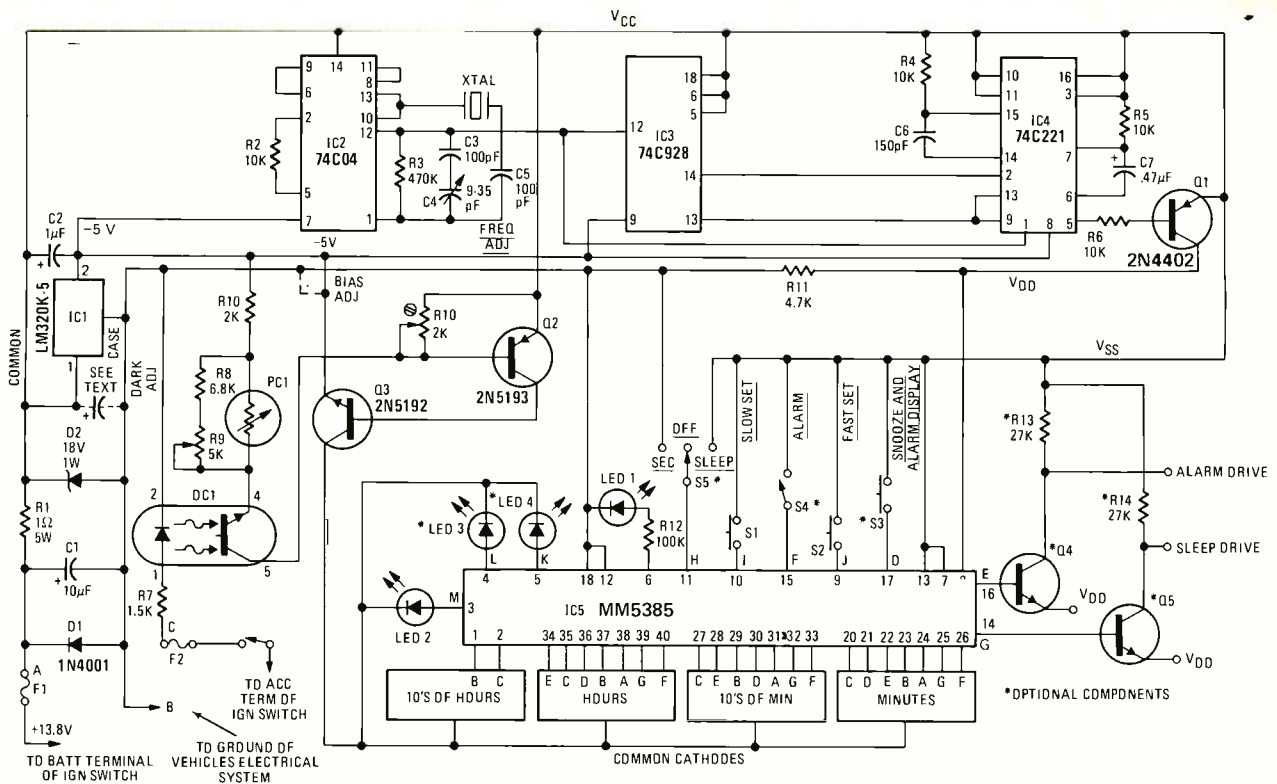

**FIG. 1—COMPLETE SCHEMATIC, AUTO DIGITAL CLOCK.** Components marked with an asterisk are optional—for alarm clock operation. Dotted-line connection from Q3 to V<sub>DD</sub> must be made—and connection from Q3 emitter to -5 volts cut—if incandescent displays are used. Emitter of Q3 may be connected to either V<sub>DD</sub> or to -5 volts, but not to both at the same time.

Crystal-controlled oscillator IC2 operates at 100 kHz. Figure 2 shows the circuit details of the oscillator. The frequency may be adjusted with variable capacitor C4 by observing the output of LED1 (more on this later). Capacitor C3 is included in series with C4 to limit the capacitance of the combination to a range of 8 to 26 pF.

The 100-kHz squarewave developed at pin 12 of IC2 is applied both to pin 1 of the dual

monostable multivibrator IC4 and to the clock input of the 3 1/2-digit counter (IC3 pin 12). During the negative transition of the 100,000th oscillator pulse, the carry-out terminal of the counter (IC3 pin 14) goes high while the oscillator pulse is still low. The carry-out serves as the input to the dual monostable multivibrator.

Figure 3 shows the logic diagram of the dual monostable multivibrator IC4. A low-to-high transition of the carry-out pulse from IC3 (pin 14) triggers the output of the first monostable multivibrator (pin 13) high on a positive input transition if the reset input (pin 3) is high and the 100-kHz clock input is low. These three conditions occur simultaneously each time the carry-out pulse of IC3 goes high. No counts from the oscillator are lost because the pulse width at IC4 pin 13, determined by R4 and C6, is only 2 μs. The pulse that appears at IC4 pin 13 every 20-ms is applied to the reset input of IC3. The 3 1/2-digit counter IC3 is fully reset long before the negative transition of the 100,001th oscillator pulse appears at its clock input. Therefore IC3 divides the 100-kHz output of the oscillator by 2000 to produce the 50-Hz signal required by IC5.

The Q output (IC4 pin 13) is also applied to the input of the second dual monostable multivibrator (IC4 pin 9). The output of the second dual monostable multivibrator (IC4 pin 5) is triggered high on a negative input transition if the reset input (pin 11) and pin 10 are both high. These three conditions are satisfied each time IC4 pin 13 goes low (every 20 ms).

The pulse width at IC4 is extended to 5 ms by the R5-C7 combination. This pulse is used to drive the base of transistor Q1. The collector of this transistor couples the 5-ms pulse to the 50/60-Hz input of the MM5385 digital alarm clock (IC5). The MM5385 is programmed to divide by 50 by connecting

pin 7 to V<sub>SS</sub>.

Figure 4 shows the waveforms developed by the oscillator, counter, monostable multi-

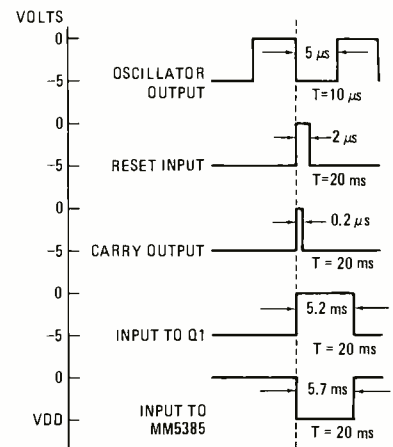

**FIG. 4—WAVEFORMS** from oscillator and multivibrator.

vibrators and transistor Q1 with respect to the common (V<sub>SS</sub> and V<sub>CC</sub>) bus.

### The MM5385 IC

The MM5385 is a monolithic MOS integrated circuit digital alarm clock that has a 12-hour display format (for a 24-hour display format, the MM5386 may be substituted). The features of the MM5385 are presented in Table I, and the base diagram is shown in Fig. 5. The various display modes are listed in Table II and the functions of the setting controls are listed in Table III.

Whenever power is applied to the MM5385, a power failure is indicated by the display flashing at a 1-Hz rate. Applying fast-set or slow-set input (pins 9 and 10, respectively) returns the display to normal.

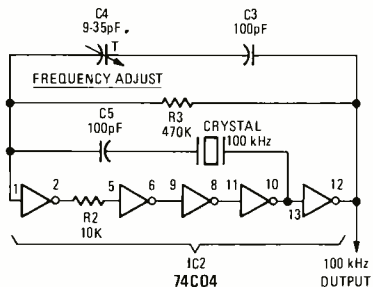

**FIG. 2—DETAIL OF OSCILLATOR** showing the connections to the 74C04 IC.

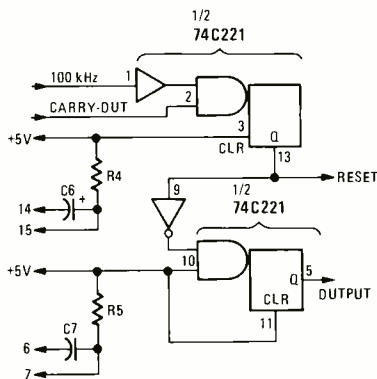

**FIG. 3—THE 74C221 MULTIVIBRATOR.** This unit is a dual monostable type.



## PARTS LIST

All resistors are 1/4-watt, 10%, unless otherwise noted

- R1—1 ohm, 5 watts  
 R2, R4, R5, R6—10,000 ohms  
 R3—470,000 ohms  
 R7—1500 ohms, 1/2 watt  
 R8—6800 ohms  
 R9—Potentiometer—5000 ohms, printed circuit board mounting, 0.5-inch maximum diameter.  
 R10—Potentiometer—2000 or 2500 ohms, printed circuit board mounting, 0.5 inch maximum diameter.  
 R11—4700 ohms  
 R12—100,000 ohms  
 R13, R14—27,000 ohms; optional for alarm clock.  
 C1—10  $\mu$ F 35 volt solid tantalum; Allied 852-5668. Also available from Valley Electronics, 4115 Franklin Ave., Sacramento, CA 95820 for 35¢ as Kemet T366.  
 C2—1  $\mu$ F 35-volt solid tantalum; Allied 852R6674.  
 C3, C5—100 pF polystyrene; Allied 852-0026.  
 C4—9-35 pF trimmer.  
 C6—150 pF polystyrene; Allied 852-0030.  
 C7—.47  $\mu$ F solid tantalum; Allied 852-5689.  
 D1—1, amp, 50 or higher PRV; 1N4001 or equal. Available from Valley Electronics, 15¢ each.  
 D2—17.7V, 1-watt Zener, Professional Replacement PR247; available from Olson Electronics, 260 S. Forge St., Akron, OH 44327. An 18-volt, 1-watt Zener may be used if necessary.  
 Q1—300-mW switching PNP silicon transistor; 2N4402 or equal. Available from Valley Electronics, 30¢ each.  
 Q2—40-watt PNP silicon transistor; 2N5193, MJE371 or equal.  
 Q3—40-watt NPN silicon transistor; 2N5192, MJE521 or equal.  
 Q4, Q5—Optional for alarm clock.  
 IC1—LM320K-5.0 negative voltage regulator.  
 IC2—74C04 hex inverter—CMOS. Available from RGS Electronics, 3650 Charles Street, Suite K, Santa Clara, CA 95050.  
 IC3—MM74C928 3 1/2-digit counter—CMOS.  
 IC4—74C221 dual monostable multivibrator—CMOS. Available from RGS Electronics.  
 IC5—MM5385 digital alarm clock.  
 OC1—Opto-isolator/coupler, MCT2 available from Valley Electronics for \$1.00.  
 PC1—Photoresistor, Clairex CL704L or CL5M4L, Archer 276-116. The Archer 276-116 or equivalent should be used with incandescent displays. Clairex available from Allied; Archer available from Radio Shack. See text.  
 LED1 to LED4—Any small LED; any color. LED2 to LED4 are optional.  
 XTAL—100-kHz crystal; this is a widely available, standard crystal. The main printed circuit board has been prepared to allow crystals up to 1 inch in diameter.  
 F1—0.5-amp fast or normal blow fuse.  
 F2—1/32-amp fast or normal blow fuse.  
 S1, S2, S3—SPST normally open, momentary pushbuttons. (S3 is optional, to be used only in alarm clock.)  
 S4—SPST miniature toggle switch. Optional for alarm clock.  
 S5—SPDT center off, miniature toggle switch. Optional for alarm clock.  
 DISPLAY 1, 2, 3, 4—0.3-inch or larger, 7-segment; incandescent or common ca-

thode LED; 15-mA-per-segment maximum; MAN-74 or DL-704. The incandescent displays and MAN45 LED displays are available at \$2.00 each plus tax and postage, from Valley Electronics, 4115 Franklin Ave., Sacramento, CA 95820.

Heat sinks—Wakefield 680-1.25-A, Allied 957-2670; see text.

IC Sockets—Calectro Cat. No. J4-635 IC Sockets, Molex IC terminals or IC sockets; see text.

Edge Connector—Calectro Cat. No. J4-645 Digi-Klips; a standard 25-pin edge connector may also be used; see text.

Filter—Optional for incandescent displays. For red LED displays, a red circularly polarized viewing screen must be used. Available with bezel from Allied Electronics, 2400 W. Washington Blvd., Chicago, IL 60612 (minimum order: \$15.00 cash), Cat. No. 658-1240 or 658-1260, or from Tracy Design Corp., 15870 Schaefer, Detroit, MI 48227, Cat. No. 920-60. Both the Allied 658-1240 and 658-1260 may be mounted to the display board.

Misc.—mounting hardware, 3/16-inch to 1/2-inch long spacers for 4-40 bolts for the Allied display-filters, spacers for the main printed circuit board, shoulder washers or nuts to space the Wakefield 680-1.25-A heat sink from the main printed circuit board.

Both the main printed circuit board and either display board are available from Henry Bosserman, 3491 Butcher Drive, Santa Clara, CA 95051; etched and drilled main board for \$11.82; etched and drilled display board for \$5.91; both for \$17.00.

With pins 11 and 17 open, the display presents time-of-day information. Sleep time can be displayed by connecting pin 11 to  $V_{SS}$  and seconds can be displayed by connecting pin 11 to  $V_{DD}$ .

Momentarily connecting pin 17 to  $V_{SS}$  inhibits the alarm output for between 8 and 9 minutes. After this delay, the alarm will again be sounded and the alarm time will be displayed. The snooze alarm feature may be repeatedly used during the 59 minutes in which the alarm latch remains set. Connecting pin 17 to  $V_{SS}$  displays alarm time.

Momentarily connecting pin 15 to  $V_{SS}$  resets the alarm latch and silences the alarm. The alarm will automatically sound again in

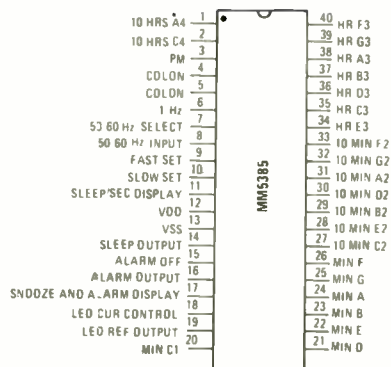

FIG. 5—CONNECTIONS TO MM5385. Pads for all option pins, except pin 18, are provided on the main board.

24 hours (or at a new alarm setting). If it is desired to silence the alarm for a day or more, the alarm "off" input should remain at  $V_{SS}$ .

The sleep output at pin 14 can be used to turn off a radio after a desired time interval

of up to 59 minutes. The time interval is chosen by selecting the sleep display mode (Table II) and setting the desired time interval (Table III). This automatically results in an output, via pin 14, which can be used to turn off a radio (or other appliances). This turn-off may also be manually controlled by a momentary  $V_{SS}$  connection to the snooze input (pin 17).

The display can be inhibited by connecting pin 18 to  $V_{SS}$ . However, for use in the Automotive Digital Clock, the display must be inhibited whenever the ignition switch is turned off. As shown in Fig. 1, the display is inhibited by removing current to the input diode of an optical isolator/coupler when the ignition switch is off. When no current flows through the input diode, the output transistor of the optical isolator/coupler is cut off. This output transistor is in series with the resistor-photoresistor combination that forward biases transistor Q2. When it is cut off, transistor Q2 is also cut off.

Trimmer R9 is adjusted to provide the desired display intensity in total darkness.

TABLE I—FEATURES, MM5385 digital alarm clock

- 50 or 60 Hz operation.
- PM outputs in 12-hour format with a colon flashing at a one second rate.
- 24-hour alarm setting.
- All counters resettable.
- Fast and slow set controls.
- Power failure indication.
- Direct interface to light-emitting diodes with forward current of 3-15 mA.
- 9 minute snooze alarm.
- Pre-settable 59-minute sleep timer.
- Radio frequency interference-eliminating slow-up circuitry at the outputs.

TABLE II—MM5385 DISPLAY MODES

*Selected Display Mode	Digit No.1	Digit No.2	Digit No.3	Digit No.4
Time Display	10's of Hours & AM/PM	Hours	10's of Minutes	Minutes
Seconds Display	Blanked	Minutes	10's of Seconds	Seconds
Alarm Display	10's of Hours & AM/PM	Hours	10's of Minutes	Minutes
Sleep Display	Blanked	Blanked	10's of Minutes	Minutes

\* If more than one display mode input is applied, the display priorities are in order of Sleep (overrides all others), Alarm, Seconds, Time (no other mode selected).

and R10 is adjusted for display intensity under maximum ambient lighting. The photoresistor controls display intensity under all other ambient light conditions. Six circuit elements, the photoresistor, the output transistor of the optical isolator/coupler, R8, R9, R10, and Q2 control the base drive to Q3. Transistor Q3 provides the current drive for all segments of the display. The photoresistor acts as a variable resistor that automatically varies the brightness of the display to provide a pleasing intensity for all conditions of ambient lighting.

Two types of displays may be used with the automotive digital clock: LED displays such as Litronix DL-704. National Semiconductor NSN74R or Monsanto MAN-74 will provide enough intensity for daytime viewing as long as direct bright sunlight does not strike the display. Figure 6-a shows the base diagram and internal connections for the Litronix DL-704 display. The readability of the LED's may be enhanced by placing a red circularly polarized viewing screen (see parts list) in front of the display.

Readability may be made perfect, even in direct sunlight, by using incandescent displays. These displays are attractive enough without a screen. However, a simple plastic screen of any color may be placed in front of the display if desired. The major disadvantage of the incandescent displays is that they may have to be replaced sometime during the life of the car—though many people would probably bet on the displays. Figure 6-b shows the base diagram and internal display for an incandescent display.

### Operation

The time displayed in the normal mode of operation (that mode in which the clock keeps track of time) may be altered by pressing either the FAST SET switch or the SLOW SET switch. Additionally, the FAST SET and SLOW SET switches may be used individually or in combination to perform other functions.

If the SLEEP-SEC switch is placed in the SEC position, the clock will continue to keep track of time, but the 1 pulse-per-second LED does not flash, and the time is not displayed. Instead, the No. 4 display changes digits at a 1 pulse-per-second rate. After a count of 10 seconds, the No. 3 display changes digits, and after 60 seconds the No. 2 display changes digits. The No. 1 display is blank.

If the SLOW SET switch is pressed while the SLEEP-SEC switch is in the SEC position, the display stops counting and is held as long as the SLOW SET switch is closed; the clock does not continue to keep track of time. This action serves to hold the time being displayed in the normal mode.

If the FAST SET switch is pressed while the SLEEP-SEC switch is in the SEC position, displays No. 3 and 4 are reset to "0"; the No. 2 display is not affected.

When both the SLOW SET and the FAST SET switches are pressed simultaneously, and the SLEEP-SEC switch is in the SEC position, the No. 2, 3, and 4 displays are reset to "0"; in addition, the time being displayed in the normal mode is reset to 12:00 AM.

When the SLEEP-SEC switch is placed in the SLEEP position, the clock will continue to keep track of time as above, but displays No. 1 and 2 are blank, and displays No. 3 and 4 display the sleep time.

If the SLOW SET switch is pressed while the SLEEP-SEC switch is in the SLEEP position, the

TABLE III—MM5385 SETTING CONTROL FUNCTIONS

Selected Display Mode	Control Input	Control Function
*Time	Slow	Minutes advance at 2-Hz rate
	Fast	Minutes advance at 60-Hz rate
	Both	Minutes advance at 60-Hz rate
Alarm	Slow	Alarm minutes advance at 2-Hz rate
	Fast	Alarm minutes advance at 60-Hz rate
	Both	Alarm resets to 12:00 AM
Seconds	Slow	Input to entire time counter is inhibited (Hold)
	Fast	Seconds and 10's of seconds reset to zero without a carry to minutes
Sleep	Both	Time reset to 12:00:00 AM
	Slow	Subtracts count at 2 Hz
	Fast	Subtracts count at 60 Hz
	Both	Subtracts count at 60 Hz

\* When setting time sleep minutes will decrement at rate of time counter, until the sleep counter reaches 00 minutes (sleep counter will not recycle).

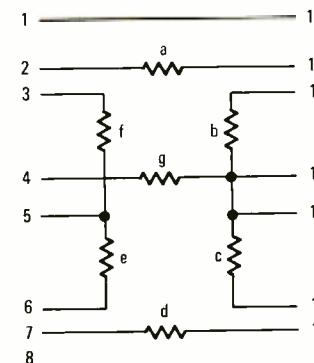
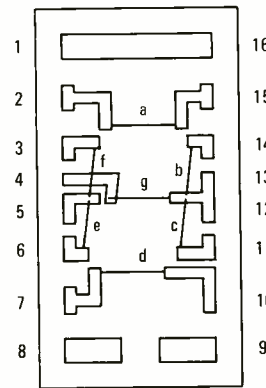
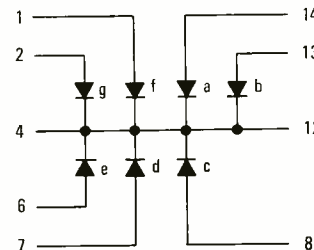
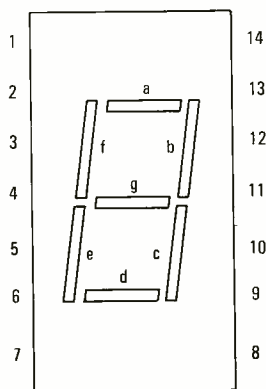

FIG. 6—CLOCK DISPLAY DETAIL. *a* shows incandescent display detail and the internal connections. (Connection between 1 and 16 is used to connect pin 15 to main board.) *b* shows Litronix DL-704 LED and internal connections of the unit.

No. 3 and 4 displays count backwards at a 2-Hz rate from "00", which is equivalent to "60", to "00".

If the FAST SET switch, or if both the FAST SET and the SLOW SET switches are pressed, while the SLEEP-SEC switch is in the SLEEP position, the No. 3 and 4 displays count backwards at a 60-Hz rate from "00", which is equivalent to "60", to "00".

With the SLEEP-SEC switch in the SLEEP position, if the SLOW SET switch or the FAST SET switch is used to adjust the No. 3 and 4 displays to a set of digits, the sleep timer will be activated for the number of minutes indicated by them. The sleep counter will immediately begin to count down to "00". During the count-down, whether the SLEEP-SEC switch is in the SLEEP or the NORMAL position,

the output at pin 14 of the MM5385 can be used to turn on a radio at the beginning of the indicated time interval (up to 59 minutes). When the sleep counter, which counts downwards, reaches "00" minutes, the sleep output drive is removed, thereby turning off the radio. The turn-off may also be manually controlled by a momentary  $V_{SS}$  connection to the snooze input (pin 17 of the MM5385). Of course, many other appliances may be controlled, including a photographic enlarger.

Pressing the SNOOZE-ALARM DISPLAY switch causes the alarm time to be displayed. The alarm time may be changed by pressing either the SLOW SET switch or the FAST SET switch. Pressing both the FAST SET and SLOW SET switches will reset the alarm time to 12:00 AM.

*continued on page 79*



# ROUNDUP



## TV Games

PART II. *New competition for prime time viewing adds a new dimension to an old medium*

FRED BLECHMAN

THE TV GAME INDUSTRY HAS RECENTLY EXPERIENCED TREMENDOUS Growth. To bring our readers up-to-date, last month we presented a listing of the TV games that are currently available.

This month, part 2 presents the details of these games.

### Game and kit roundup

Because of design secrecy, FCC approval pending or incomplete designs, many sources contacted for information did not reply. Here are some details on those that replied, or where information was derived from another source.

**Advanced Electronics:** Offering only plans, PC boards and IC's, Advanced Electronics caters only to the advanced builder. The plans are clearly presented and printed, and appear to be quite complete. Also, the variety of plans offered is most extensive. For example, the 9-page Pong plans cover Pong, Tennis, 4-Player Tennis and Soccer. For an additional \$7 you can order Pong Extras (8 pages) that cover circuitry for 7 more options, most of them easily added to the original games: Handball, Warball, Elimination, Fotsball, Digital-Controlled Paddles, Multiple Paddles and Multiple Balls.

Plans for Anti-Aircraft 1 & 2 (10 pages) are more complex,

and involve the use of 107 IC's and a PRCM (pre-programmed read-only memory). The game of Anti-Aircraft consists of missile firing units at the lower corners of the screen, with airplanes randomly moving across the sky. Missile firing and angle are controlled by the players with the intent of hitting an enemy plane which, in one version, can climb or dive to avoid the missiles. This is a game equivalent to the type found in amusement centers, even to the flashing of the screen when a plane is hit.

The 12-page plans for Jaws-2 and Space Race have some similarities with Anti-Aircraft—69 IC's are identical but are wired differently for control and image presentation. Jaws-2 shows 2 divers, a fish and a shark displayed on the screen. Players (divers) compete to catch the most randomly moving fish before being "eaten" by the randomly swimming shark that is programmed to home in on any nearby diver!

Space Race has player-controlled rockets that attempt to move vertically up the screen without being hit by small horizontally-moving meteoroids.

Since the clock, sync, score and video output circuits are designed to be the same for all of Advanced Electronics'

games, they offer a PC board for \$12.95 that holds 28 IC's plus various resistors and capacitors. For the Jaws-2, Space Race and Anti-Aircraft 1 & 2 games, the PC board to hold 40 IC's, a ROM (Read-Only Memory) and associated circuitry, is \$15.95; this is for locating and moving the objects and forming their images on the screen.

**Advanced Microcomputer Products:** The General Instruments AY3 8500-1 MOS/LSI TV IC, used in the majority of ready-made TV games, is offered by itself for \$39.95, with a PC board and instructions for \$49.95 or as a kit with video output (no case) for \$69.95. The instructions cover all six games (Tennis, Hockey, Squash, Pelota, and Rifle Shoot 1 & 2), but the parts in the kit do not include the photo-sensitive rifle parts to be offered at a later date.

The plans are not designed for a beginner and are poorly reproduced. However, the assembly of a TV game from this IC is relatively simple and involves mostly the addition of switches. The external oscillator and video output circuits require two inexpensive IC's. The advantage of this kit is the number of builder-selected options available with this very versatile game chip.

**Allied Leisure Industries:** Manufacturers of 29 different coin-operated pinball and specialty amusement games, Allied Leisure has entered the home video-game market with two

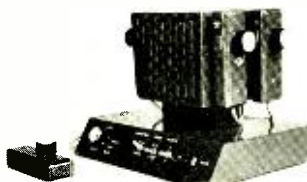

**ALLIED LEISURE,** (above) the *Name of the Game No. 1*, (left) the *Name of the Game No. 2*.

units. One is a 2-player unit, another is a 4-player unit. Each player uses a hand control unit with a 12-foot cord.

**APF Electronics:** This handsome furniture-styled console in black, walnut and silver, allows two players to compete in three games (Tennis, Hockey, and Squash), or 1 player to

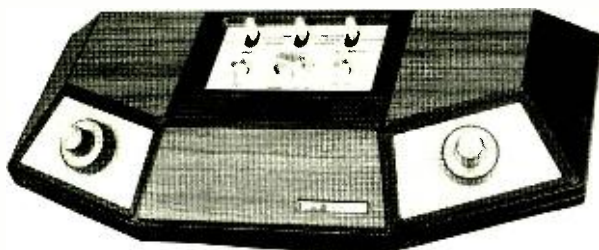

**APF ELECTRONICS,** *TV Fun Games*.

compete against the game. It uses most of the options available with the General Instrument IC, except for the rifle games.

**ARS Systems:** If you like to do it yourself, ARS offers plans for a Basic TV Ping-Pong Game (6 sheets) for \$3.25 that includes a description of operation and construction information, a complete parts list, parts sources, parts layout diagram and a schematic. This is definitely for an advanced experimenter. The instructions include an on-board modulator for TV Channels 2, 3 or 4. Over 50 IC's are used in the basic design. Separate plans are available for Score Display (a pair of 2-digit LED displays that count from 00 to 99 with reset capability) for \$2.25; Sound plans are \$2, and plans for a regulated power supply (5V 1.5A) are \$2.50.

**Atari:** The basic *Pong* unit, also sold under the Sears label, was one of the two initial video game entrants into the consumer field (the other was the Magnavox *Odyssey*). One of

the unusual features of the Atari units is the variation of ball speed and deflection. In a volley (a series of paddle contacts with no misses in-between), the ball speed is constant for the first three hits, and the ball deflects off the paddle at any one of 7 angles (depending on which part of the paddle contacts



**ATARI,** *Super Pong*.

the ball). However, on the 4th through 7th paddle contact in a volley, the ball speeds up and the deflection angles are narrowed. The 8th paddle contact speeds up the ball to its top speed, and the paddle deflection angles are their narrowest. You can play against the machine by positioning the paddles to "lock-up" the ball in a repeating pattern.

**Cal Kit:** The basic *Ping-Pontronics* kit (TV-3) uses 12 IC's mounted on a single PC board and is furnished with an excellent assembly manual. It still is not recommended for beginners, however. An optional accessory kit (TV-4, \$33) that can be mounted directly to the main game board adds scoring, two sound effects and automatic serve to the basic game. A special drilled and silk-screened case (TV-11, \$12.50) contains the whole game, including options. If you want the basic PC board, it's available as TV-1 for \$12. The PC board for the sound and score add-on option (TV-2) is \$8.50. For \$15.50 you can order all the IC's for the basic game (TV-6) and all the basic game sockets (TV-8) for \$6.

The finished basic game has several unusual features: the ball speed can be controlled over a wide range, from rather slow to very fast, and SLAM buttons cause the ball to double in speed for catching your opponent off guard. A feature called *Aimshot* allows you to closely control the ball return angle—it depends on what part of the paddle hits the ball. While some games provide up to seven return angles based on paddle contact, this game provides 16! A CYBERNETICS MODE switch selects either man against machine, for either side, or machine versus machine.

Games played are Ping-Pong, Gravity (ball bounces in an arc simulating gravity), Handball (1 player) and Basketball (player tries to shoot ball through gap in upper court boundary).

**Coleco:** One of the first games using the General Instrument IC to be sold in stores—usually in the toy department—this unit offers many of the options contained within the IC. The on-screen digital scoring, 3-toned sound, and variations in



**COLECO INDUSTRIES,** *Telstar*.

ball-speed and paddle-size (beginner, intermediate and professional) keep the game interesting. Games played are Tennis, Hockey and 1-player Handball (so you can practice against the machine).

The Classic model appears to be the same unit in a more luxurious wooden case.



**Continental Microsystems:** Three versions of Bang are awaiting FCC approval as this is being written. It is possible that the V44CS unit, when it reaches the stores, will have *wireless* remote controls and a photoelectric rifle for the two rifle-games. In the rifle games, a bright spot moves across the screen. You aim the rifle at the spot and pull the trigger. The rifle has a lens and photocell to detect if you are precisely on target. If you pull the trigger and are right on target, the trigger pulse and photocell pulse coincide to register a hit, and the target disappears. The other games are the typical GI IC games. To add color, the GI IC is used with additional circuitry.

**Exterprex:** The four games played with this unit are Tennis, Hockey, Squash and Robot. Most of the options offered by the GI IC are switch-selected. The levers used to control paddle movement are linear potentiometers and are more natural in use than the knobs (rotary potentiometers) found on most units.

**Entex:** Basically a toy manufacturer, Entex has entered this field with a game that has several unique features. It operates on the UHF channels of your TV (adjustable from Channels 26 to 31). It has a vertical and a horizontal hold control on the console to lock-in an unsteady picture. Both vertical and horizontal paddle movement can be controlled to play Tennis, Table Tennis or Squash. Scoring is manual, using score-keeping dials.

**Fairchild:** The Video Entertainment System is the first home video electronic game to use replaceable *Videocart* cartridges to provide an unlimited number of format selections. Two games resident in the System are Tennis and Hockey. The first add-on cartridge (\$20) adds Tic-Tac-Toe, Shooting Gallery and Doodle (a tracing game.) A total of 17 games are planned to be available by Christmas, with others to follow. Educational and other applications are also planned.

The heart of the system is the game console which incorporates a Fairchild F8 Microprocessor and four solid-state RAM's (Random Access Memories).

Although the comparison chart seems lacking in checkmarks for this unit, that's because specific information is lacking as this is written, not because this unit doesn't have the tabulated features. In all likelihood, this system will offer more options than any other unit covered, simply because of the inherent flexibility of the microprocessor/cartridge design approach.

**First Dimension:** Four different models are offered. The *Video Sports 76* uses many of the options of the GI chip, with the *Video Sports 76C* adding color when used with a color TV. The *Mark IV* uses a different chip and slide controls, but otherwise is very similar to the *76C*. The model FD 3000W is



FIRST DIMENSION models *Mark IV* (left) and *FD3000W* (right).

a more advanced design offering six games in one, two or four players, and even features boundary adjustment controls for a perfect display. (This compensates for non-linearity on many TV sets.) Surprisingly, however, for such a sophisticated design, horizontal advancing bars above the court boundary indicate individual scores instead of on-screen digital scoring.

**Global Video:** A large 50-inch diagonal big-screen color television receiver primarily designed for taverns, lounges, offices, schools and clubs, this unit can be used with closed circuit television, video cassettes, slide and movie projectors and also with their own 4-player *Challenge* video game.

**Heath:** The lowest-priced complete kit using all the features of the GI IC, this game is intended to be connected to Heathkit solid-state color and black-and-white TVs, with five easy clip-on connections to the chassis (and a cable connector



HEATH model *GD-1350*

for easy removal). Two target games will not be usable until the optional rifle is available early next year.

**IEA:** Three models are offered by this Canadian manufacturer. The *Tele-tainment II* plays seven games: Ping-Pong, Squash, Handball, Basketball, Catch, Trapsheet, Zany Rebound, and Crazy Catch. It appears to use discrete IC's rather than a dedicated game IC. *Tele-tainment III* and *IV* are almost identical; the *III* has a stylish molded plastic console with one wired remote control, while the *IV* is housed in a solid mahogany case of the same design, without remote.

**Interfab:** This very versatile game, formerly called *Fong IV*, is offered in three kit forms. The "B" kit is fully wired and tested with vertical and horizontal sweep oscillator tuned. The unit only requires mechanical assembly into the main cabinet and remote control enclosures, and costs \$99.50. For \$89.50 you can order the "C" kit that has the main board



INTERFAB, *TV Tennis* shown above. Internal view of *TV Tennis* shown at right.



completely soldered and short-circuit tested, but requires cabling to the switches and controls. The "D" kit, for \$79.50, has all the main board components properly mounted and held to the top of the board in a plastic package. Simply solder on the underside, remove the plastic, then wire to the controls and switches.

All kits include a pre-drilled cabinet, pre-drilled remote control cases, all hardware, wire and cables. The unit uses 43 IC's, 93 resistors, 42 capacitors, 18 diodes and 4 transistors mounted on a two-sided PC board, so it's not for a beginner. The instructions are adequate for assembly and troubleshooting, but if you lack the equipment or know-how and your unit doesn't work properly, Interfab will repair and tune your unit for \$15 including return postage!

Since you build this unit yourself, you can make modifications. For example, you can add or change resistors to move the borders of the two basic games, Tennis and Handball. You can replace the knob controls for vertical and horizontal movement with joysticks. Also, you can modify the two automatic games (man vs. machine or machine vs. machine) to allow a miss now and then. You do this by inserting a 470K 1/2W resistor in series with the AUTOMATIC switch for either or both sides.

The output of this game, as supplied in kit form is video. However, the PC board is etched for the addition of a UHF modulated oscillator using a 2N5770 transistor, 4 resistors, 2 capacitors and a piece of brass or copper. The typical circuit is

furnished by Interfab or could be found in radio circuit handbooks—or you could use the PXV-2A VHF Modulated Oscillator mentioned earlier in this article.

**Interstate Industries:** This unit plays the GI IC standard games Tennis, Hockey, 2-player Handball and 1-player Handball in black-and-white, but offers all the available paddle and ball options as well as using wired remote controls. The game is packaged in a relatively small smartly-styled main console.

**James:** Kit A, for \$179.95, consists of a *professional* game PC board that is assembled and tested, and 2 *professional* Kraft joysticks (these joysticks are used in radio-control for model airplanes and are very high quality). This is the same game seen in many commercial establishments. Accessory B, for \$3.95, consists of six feet of ribbon cable (flat multi-conductor color-coded insulated wires) and three switches.

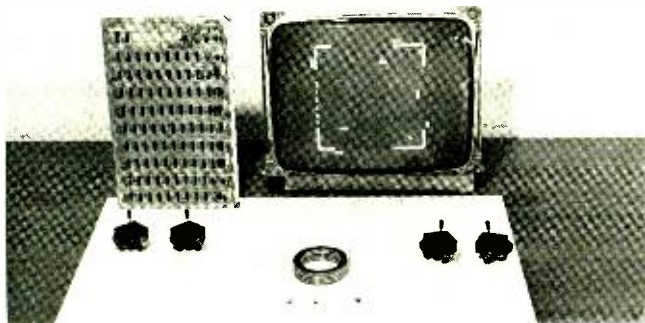

JAMES ELECTRONICS, Accessories A, B and C.

You can add two more Kraft joysticks with Accessory C for \$39.95. There are actually four ways to play this game, selected by two switches: 1 player against the machine, 2 players against each other, 3 players against the machine or 4 players against each other. Scoring marks show at the beginning of a game and one mark disappears with each score down to zero. No enclosure is offered and the output is strictly black-and-white video. Also, a regulated 5-volt 2-ampere power supply must be added.

**Lafayette:** The *Tournament 2000* is made for Lafayette by Unisonic. It uses a GI chip and offers most of the options, including the two rifle games. It appears to be the only unit in this report that INCLUDES the electronic rifle, which has the

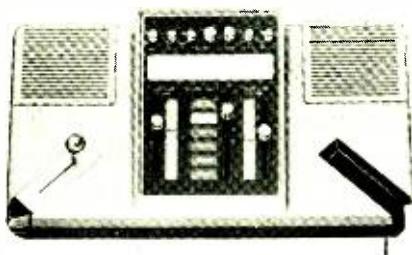

LAFAYETTE, *Tournament 2000*.

additional feature of a removable stock and barrel to convert it into an electronic pistol. With wired remote slide controls and manual scorekeeping in addition to the on-screen digital score display, this may be the most versatile unit in its price range. Furthermore, Lafayette lowers the price at times in limited special promotions.

**Magnavox:** Although the older *Odyssey 100* and *200* models

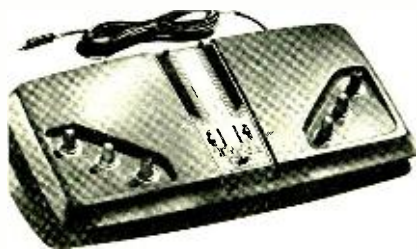

MAGNAVOX, *Odyssey 500*.

are still in some stores, the newer models (300, 400 and 500) have more features and are being heavily promoted. Also, Magnavox is the first to offer a video game built-into a color TV receiver. They are also offering the first ready-made home video game (*Odyssey 500*) with simulated playing figures on the screen instead of rectangles, and full-color playing fields. (Some color displays only have colored paddles, ball or score). The regular games are Tennis, Hockey and Smash (Handball) with Soccer added to the model 500 and Smash omitted from the model 100.

**Microelectronic Systems:** The games are *Ricochet* (player versus machine in 3-wall Handball), Racquetball (2-player 3-wall Handball), Tennis and Hockey. Various switches and buttons provide 72 possible game combinations!

**National Semiconductor:** This game uses the National MM57100 TV Game IC to provide all the logic necessary to generate backgrounds, paddles, ball and digital scoring for Hockey, Tennis and Handball. A 3.58 MHz crystal and a divide-by-3½ IC provide full color—including different colored backgrounds for each game—on color TV sets. There

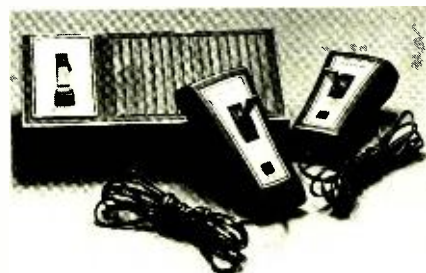

NATIONAL SEMI-CONDUCTOR, *Adversary*.

are three selectable paddle sizes and the ball speed increases automatically after 4 hits. Hockey can be played with one player for practice against the machine. The paddles deflect the ball or puck at any one of seven angles depending upon the point of contact with the paddle, but no switch is provided to change these angles. Unlike many units, this design is limited to manual serve only and the sound comes through the TV speaker. The unit is strictly AC powered.

**RCA:** The Distributor and Special Products Division has filed an application for FCC type approval for a new TV game. Although, at presstime, we have little information on this new game, it is said to be based on the RCA COSMAC microprocessor. According to present plans, it is tentatively scheduled for introduction on a regional basis during January 1977, and will be offered for nationally later in the year.

**Radio Shack:** This unit appears to be identical with the Microelectronics *Ricochet*, except for the names given to the games.

**Southwest Technical Products:** This is a relatively simple kit using only 10 IC's, but only has video output. Single white squares on each side of the screen represent space ships that can be moved vertically by the players. Each can also fire a single-burst "laser beam" at the opponent. If hit by the beam, the opponent's ship disappears from the screen and he loses. However, if the laser beam misses, the aggressor's ship blinks for several seconds while his laser is "recharging". During this recharge time (since he can't fire) his only defense is to keep out of his adversary's line of fire. To add to the fun, the movement controls are intentionally sluggish!

**Tokyo Phoenix:** The four games in this unit are the standard GI IC games of Tennis, Hockey, Squash and 1-player Handball. The sound comes through the TV, so there is a possibility of leaving the game on unintentionally after turning off the TV.

**Universal Research:** The *Video Action* series includes a Game Table and an educational game called Fact. The Game Table appears to be the *Video Action IV* with a black-and-white video monitor built into an eight-sided table with a card-playing top and checkers/chess/backgammon inserts that are removed during video game play. The automatic

*continued on page 84*



# CB Radio

## 23 or 40 When Should You Buy?

*If you're hesitant about buying a 23-channel CB because the new 40-channel models are on the way—don't be. Here's why*

FRED PETRAS

LIKE MANY READERS OF RADIO-ELECTRONICS WHO ARE THINKING of buying a Citizens band radio, you may be caught in the confusion surrounding CB's expansion from a 23-channel to 40-channel medium on Jan. 1, 1977. And, typically, you may have decided to forego your purchase. "Why buy a 23-channel CB now, when in a matter of weeks it will be obsolete?" was the question you posed to yourself, and answered with a decision to sit tight.

The Federal Communication Commission's announcement in late July that as of Jan. 1, 1977, 17 new Class-D channels would be added, also had an effect on current owners of CB equipment. "In effect," they told themselves, "come the New Year, our 23-channel rigs are dead as a dodo."

Both negative assumptions are false. The prospective CB buyer, holding off, may be doing himself a disservice. That decision may be costing him money. Why? Because at the moment the CB market is a big bargain field, with prices of 23-channel transceivers slashed as much as 50 percent by manufacturers and dealers to make way for new 40-channel models. If ever there was a time to buy a CB, now is it. Instead of buying a "starter" model as you may have been planning, you can now buy a deluxe unit and still have a few dollars left in your budget.

"But," you say, "Why buy something that will be obsolete?" Push the thought from your mind: you have some options, some "outs," to protect your investment.

### Buyer protection

Those options are in the form of "buyers' insurance plans" being offered by manufacturers and/or their dealers to protect your investment. The 23-channel set you buy today—at a big-bargain price—can either be factory-modified at a low cost to accommodate the 17 new channels, or, you can exchange it for a 40-channel set, again at low cost, or, you can get a big discount or trade-in on a new 40 by way of a certificate you obtain with your 23-channel set purchase.

Typical of these plans are those from Hy-Gain and Pearce-Simpson. If you buy one of their current 23-channel transceivers and decide in 1977 that you'd like 40-channel capability, merely send the unit back to the factory (postpaid) along with \$25. It will be returned to you (postpaid) "remanufactured" with 17 more channels. Under Patcom's

plan, consumers buying its Pace CB equipment before Jan. 1 can have it updated to 40 channels any time during 1977 for "no more than 20 percent additional cost," or \$25 to \$90, depending on the unit. SBE has a similar plan, with conversion costs ranging from \$35 to \$95. Under RCA's plan, conversions cost \$40; J.I.L. charges \$35.

Sharp Electronics offers purchasers of a 23-channel rig a chance to exchange it for a brand new 40-channel unit at a cost of only \$30, up to Jan. 31, 1977.

And there are other protection plans. Dynascan, for example, has a two-way deal: if you buy one of its Cobra 23-channel models now, you get a certificate entitling you to a conversion to 40 channels at \$40, or a \$40 discount on a new 40-channel Cobra CB. Handic allows purchasers of its 23-channel CB's to turn in a certificate for a new 40-channel model at half price (without trading in the 23). Colt Communications, under their "Investment Protection Trade-In Program," allows purchasers of its 23-channel model 280, through March 15, 1977, the option of trading in that set



COBRA 139

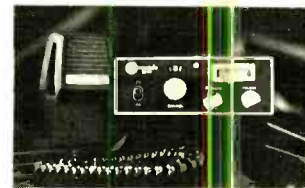

COMMANDO 2310



EICO 7723



GEMTRONICS GTX-23

toward a new 1977 Colt model and apply 100 percent of the purchase price paid against the suggested retail price of the 40-channel unit. Kris, Inc., is offering purchasers of its 23's up

to \$140 credit toward purchase of a 40-channel model.

Perhaps the most generous program—especially in terms of time—is offered by Channel Master. Under its "Future 40" buyer protection program, purchasers of its 23-channel transceivers (who also receive a \$39.95 *Power Wing* antenna free with their purchase) receive a certificate guaranteeing either conversion or swap privileges for a span of 2½ years, in three "time slots." Between Jan. 1 and June 30, 1977, a retrofit conversion on the firm's model 6832 will cost \$44.95, a swap

determine what the protection plan is, and make sure it applies to the unit you intend to buy. Another point to consider in the plans outlined above is that Dec. 31 is given as the cut-off time for purchases of 23-channel rigs that will be protected. As we go to press, rumors are rampant that more 23's are on the way from the Orient and some will be arriving in the United States too late to be sold by Dec. 31. It is quite possible that some of the protection plans will be extended, to cover 23-channel set purchases after Jan. 1. Again, check before you buy.)

### When to buy

The one outstanding factor that makes the purchase of a 23-channel CB now a no-lose proposition is that in many, if not most instances, the price differential between what you *save*



**BOSHEI C-7500**



**BROWNING SST**



**HANDIC 2350**



**GENERAL ELECTRIC 3-5820**

for a new 40-channel unit, \$74.95. From July 1, 1977 to June 30, 1978, the retrofit costs \$54.95, the swap \$84.95. From that point to June 30, 1979, the conversion will cost \$64.95, the swap \$94.95. Such conversion/swaps will be priced somewhat lower on the firm's model 6830.

(Channel Master notes that it is making this kind of offer because it feels that "Forty-channel operation will be generally limited until 1978. There will be over 25 million mobile 23-channel units in use in 1977, and very few 40-channel units. Therefore, a consumer may not wish to exercise his retrofit or swap options until he feels that enough 40-channel transceivers are on the air.")

For those prospects considering a combination stereo player/CB rig, Clarion Corp. of America has an interesting trade-in program. Purchasers of its component-type in-dash cassette and cartridge combinations that feature a separate 23-channel transceiver module can have a brand new 40-channel version of the module, along with a new microphone, for about \$129.

At presstime, other companies were finalizing plans for

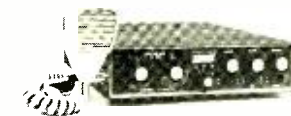

**PALOMAR Digicom 100**



**PACE CB-166**



**PEARCE-SIMPSON Bobcat 23C**



**GLOBE ELECTRONICS 9000**

by buying a 23-channel rig will be *greater* than the amount you might pay for a conversion, exchange, or trade-in. For instance, you might buy a big-name 23-channel CB at \$89.95 now versus the regular price of \$139.95, for a saving of \$50, and later pay only \$25 to \$40 for a conversion.

And there's another way to look at it. While you can buy a 23-channel now at a bigger-than-usual discount, you will not likely be able to buy a 40-channel at discount when they initially become available. The old law of supply and demand will prevail. The new 40-channel models will be in short supply for many months, according to the best information we have at presstime. This will be due to the short production period between the time the FCC type-approves the new sets, and January 1, their availability date.

Furthermore, the new 40-channel models will be higher priced than their 23-channel counterparts, by an estimated average of 20 percent. Thus, the new 40-channel version of the \$139.95 23-channel model you bought for \$89.95 will sell for about \$169.95. Allowing \$25 to \$40 for a conversion, you come out at least \$40 ahead by buying that 23-channel model **NOW**.

Another assurance that 23-channel CB will not be obsolete



**MIDLAND 13-882C**



**KRIS XL-23**



**JOHNSON 123SJ**



**HY-GAIN Hy-range V**

conversions, exchanges and trade-ins to encourage prospective CB'ers to go out and buy 23-channel CB now, with the assurance that their purchases have a long future and will not be obsolete.

(NOTE: While the above applies to most major, nationally-advertised brands, there are exceptions that generally apply to products from lesser-known manufacturers. Before you buy,



**SBE Cortez**



**J.I.L. 606CB**



**RCA 14T200**

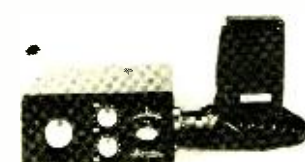

**NUVOX TC-5020**



comes from the industry itself. A handful of American companies who make CB's for export to Canada and European countries—where 23-channel will prevail—intend to continue making some 23-channel models for the American market. Thus, if you find you don't actually need 40 channels, you can go out and buy a 23-channel model next year or the year after, albeit not at the kind of discount you'd obtain today. One such company is Pathcom, producer of Pace brand CB products. RCA, which will be marketing nine 40-channel models in 1977, early in October introduced two new 23-



LAFAYETTE Telsat SSB-100



PANASONIC RJ-3200



ROBYN DG-30



SHAKESPEARE GBS/5000

channel models. A company spokesman said the move was in line with RCA's belief that "Most CB activity will remain on the existing 23 channels for a long time." He went on to say "There are approximately 15 million 23-channel CB units in use today. Throughout many areas of the country, 23 channels are more than sufficient for normal operation."

One Massachusetts sales rep firm, in a letter to its dealers, noted that "after Jan. 1, 1977, 90 to 95 percent of all general CB communications will continue on the present 23 channels for several years at the very least. And at current price levels, the 23-channel sets are *quite a buy*."

In fact, some manufacturers envision a continuing life for 23-channel CB even after 40-channel hits the market. Their reasoning is that the two types are actually two product categories, with the approximate 20 percent price differential between them automatically setting them up as such. Priced lower, the 23-channel models will attract the first-time buyer or the consumer on a budget. The 40-channel models will be "upgrades" or "stepups" for the more sophisticated or more involved CB'er.

Current owners of 23-channel transceivers, worrying about their equipment being as dead as a dodo bird, should not have such fears. Their equipment will have the potential to serve



CRAIG 4103



ROYCE 1-662



SILTRONIX Cherokee SSB-23A



STANDARD Horizon 29

them indefinitely. The FCC will be among the first to point that out. As noted in the October issue of *Radio-Electronics*, FCC chairman Richard Wiley said, "No present CB sets will in any way be made obsolete. The FCC is very disturbed by

any suggestion to the contrary." The suggestions referred to by Mr. Wiley are a variety of newspaper and magazine reports negative about 23-channel CB. One Chicago newspaper, for instance, erroneously topped an article about the upcoming channel expansion with the headline "Buying A CB Radio? Wait, Advise the FCC."

(As of October 1, the FCC was processing some 85,000 CB license applications per week. This would bear out widely scattered reports to the effect that consumers "in the know" are not letting 40-channel CB keep them from investing in 23-channel CB.)

### The future of 23 channels

As far as 23-channel CB's becoming obsolete is concerned, the following are some reasons why it won't. First off, the CB world will not change overnight. It will, in effect, gradually phase out from one state-of-the-art into another, with the new state-of-the-art not necessarily a worthy advance for all CB'ers. Overall, there will be a noticeable change—but only after a considerable while. For instance, it will be many months, perhaps as much as two years according to some manufacturing sources, before enough 40-channel models will be sold so that new-set purchasers will have someone to talk to. And this 40-channel CB population rise will occur mostly in major cities where channel congestion is greatest. The rural-area user may go begging for lack of possible air contact on the new channels.

Contributing to a lack of CB communications on the new channels will be an expected shortage of 40-channel rigs in the first half of 1977. As noted, manufacturers will have only a short period in which to make new equipment before the sale date arrives. Some companies, whose products fail to make the grade at FCC testing labs, will not have 40-channel sets for sale come Jan. 1.

Secondly, no one really expects a mad rush of consumers to the nearest CB store to pick up a 40-channel model. Initial purchasers will be CB "nuts"—those who have to be first on the block with the latest; and avid keepers-up-with-the-Jones'. According to many sources—manufacturers, sales representatives, dealers—most people with 23-channel sets will stick with them once they check out all the ramifications of the 23/40-channel situation, and find that there are really very few reasons to switch to 40-channels. Let's enumerate some of those ramifications . . .

- Most CB'ers settle down to operations on a few channels once they've got their basic dial-chasing out of the way. These few channels prove sufficient in most localities.

- The opening of 17 new channels will not affect the two most popular channels—9 and 19. Channel 9 will continue to be the emergency channel. Channel 19 will be the truckers' channel.

- All current 23 channels will continue to be used. Only Channel 11 will be modified; now a "calling only" channel, it will lose that restriction come Jan. 1.

- If you live in a congested metropolitan area, the addition of 17 new channels will eventually decongest the current 23-channels to some degree—making for better communications on them.

- The new channels will be more interference prone because many illegal single-sideband sets operate on them.

- Many industry executives say that 23-channel rigs will prove to be better performers than most of the upcoming 40-channel models because of the FCC's strict modulation requirements for the new models. Those requirements will cut the broadcasting range of the 40-channel models. It's also claimed that the strict new chassis radiation requirements will also contribute to reducing transmission range of the new sets.

So, summing up, we'd like to say this: There is no reason to hold off buying a 23-channel CB in the current buyer's market, and possibly pass up one of the best electronic product bargains you may ever see.

R-E

# Analog Voltmeters

*alive and well today and tomorrow*

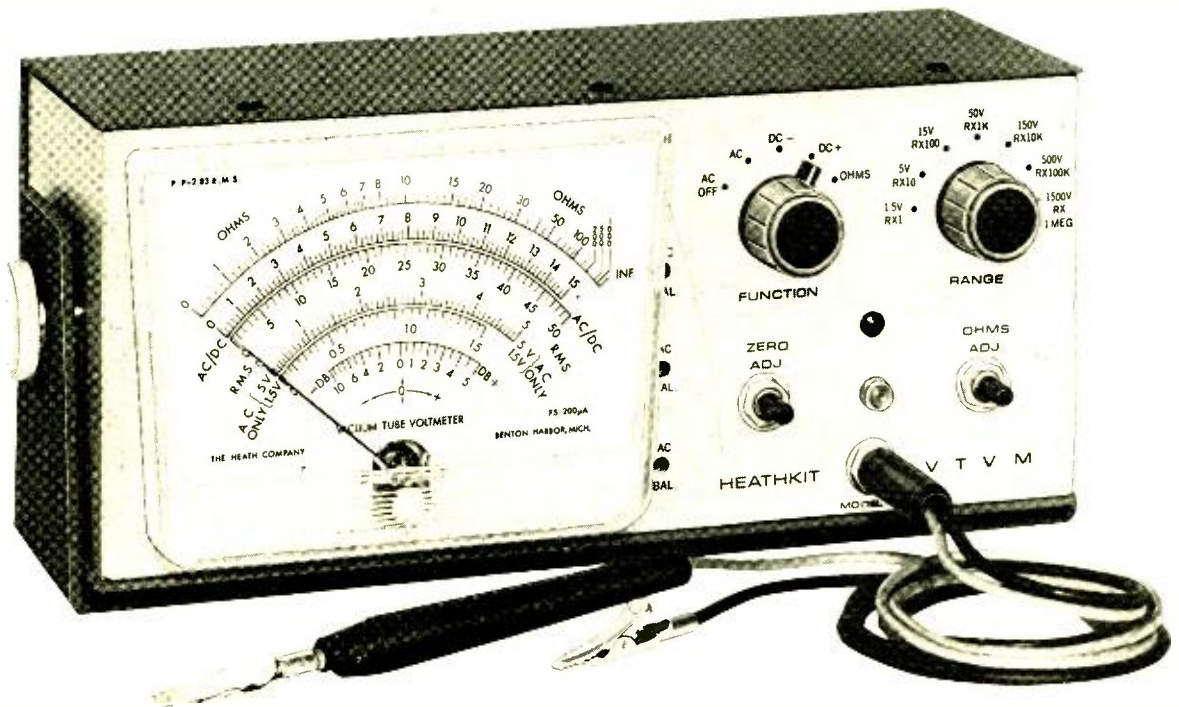

*The analog voltmeter has not been abandoned. Here's a rundown of the different types currently available—their features, specifications and applications*

**CHARLES GILMORE\***

\* Manager Design Engineering, Heath Co., Benton Harbor, MI.

AS THE COST OF THE DIGITAL MULTIMETER continues to go down, many people are beginning to worry about the future of the analog multimeter. Although it has lost some of its popularity to the digital meter, the analog instrument still has many advantages. Foremost is that of price. The lowest priced digital meter, with a 1 to 1.5 percent accuracy, is in the \$80 range, while \$30 still buys a perfectly suitable electronic analog meter with almost as great accuracy (2 to 3 percent).

The analog meter will be with us for some time, due to its sheer numbers. Digital multimeters number in the hundreds of thousands—*analog* voltmeters in the millions. That many meters will not be simply thrown away.

The analog meter actually offers advantages over its digital counterpart in some operations. When the measurement objective is a trend rather than a specific voltage, the analog meter has the simplest display to interpret. Examples of trend

measurement are *peaking*, *dipping*, and *zeroing* (nulling). Many measurements—especially in electronic maintenance or service—are trend rather than absolute measurements. The digital meter is especially difficult to use in this mode, and can cause error and frustration.

Frequently, special scales are needed for certain meter uses. Special nonlinear scales, such as decibels, are particularly difficult to develop with the digital meter, but can be set up on an analog meter with little or no added expense. (The person who needs a meter calibrated in decibels is likely to have an analog meter for that purpose.)

Often the analog meter offers the lowest cost, truly portable, multifunction operation. Small size is expensive in any meter. Small analog meters tend to be lower in cost than correspondingly small digital meters. Part of the reason for the reduced size is the normally smaller power requirement of the analog meter.

## What is an analog multimeter?

Figure 1 is a simplified block diagram of the electronic analog voltmeter. Essentially not far different from its passive cousin the VOM, the electronic analog meter contains an amplifier in addition to the meter and the input attenuator. The rectifier, which permits AC operation, may be located in either the input to the amplifier, or after it.

The amplifier gives the electronic analog voltmeter some advantages. It provides high input-impedance, thus reducing circuit loading considerably. It amplifies the input signal so the voltmeter's maximum sensitivity is not determined by the sensitivity of the meter movement itself, and it permits operation over a wider frequency range than is possible with simple meter rectifier types.

## Three kinds of meters

Electronic analog multimeters come in three basic types. The original was the



vacuum-tube voltmeter (VTVM). Though the sophisticated electronics technician may turn his nose up at the vacuum tube, many VTVM's are still built and sold today. It is a moderately accurate, highly stable, low cost voltmeter. To some extent the VTVM has been replaced, especially in the more sophisticated applications, by the transistor voltmeter (TVM). Most TVM's do all a VTVM can do, and more. There are relatively few low-cost TVM's on the market today.

The transistor volt-ohmmeter (TVOM) is a close relative of the TVM. Frequently the only difference is that the TVM is designed as a bench instrument while the TVOM is designed as a portable one. The TVOM is often referred to as an FET VOM. This name comes from the field-effect transistor used to obtain a high-impedance input.

A third class of electronic analog meter is the AC instrument. There are both AC VTVM's and AC TVM's. The AC voltmeter measures AC voltages only, though it can measure very low levels of AC, especially compared to the ordinary VTVM or TVM. Some AC voltmeters are also able to display decibels on a linear rather than the conventional compressed scale.

### The VTVM

Figure 2 is a simplified schematic diagram of two conventional dual-triode DC VTVM's. Note the first circuit may be drawn two ways, as a bridge circuit with two of the arms being triodes, (Fig. 2-a) or as a differential amplifier with one input referenced to common (Fig. 2-b). The VTVM bridge circuit may also be drawn as shown in Fig. 2-c, which when redrawn in Fig. 2-d, shows a pair of cathode followers.

The bridge or differential configuration has a number of advantages. It provides a simple method of making a zero adjustment, and if the tubes are well matched, it is quite free from effects caused by time and temperature.

The input attenuator of the VTVM is usually a simple voltage divider with a total series resistance of 10 megohms. The accuracy of the divider is dependent on the accuracies of its resistors—the loading by the tube is negligible.

The input impedance of the VTVM is often specified as 11 megohms. This consists of the 10-megohm impedance of the attenuator plus one megohm at the probe tip. The additional megohm, which is shunted by the capacitance of the probe's shielded cable, forms a low-pass filter. This filter keeps AC signals (especially RF) from the input attenuator and out of the tube bridge, which is sensitive to such signals. (The 1-megohm resistor at the probe tip must be taken into account when calculating the voltage division.)

When the VTVM is switched to AC, a rectifier is inserted in the signal path. This peak-responding voltage-doubler is inserted ahead of the bridge, as shown in Fig. 3. Most range attenuation takes place at the DC attenuator, after rectification. This is because the greater the AC signal on the rectifier (without exceeding breakdown voltage) the more linear the conversion to DC. Non-linearities become great enough on the lowest AC range to

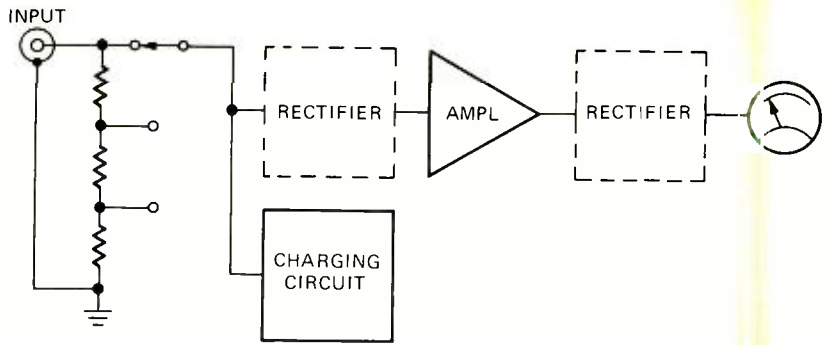

FIG. 1—ELECTRONIC ANALOG MULTIMETER, generalized block diagram.

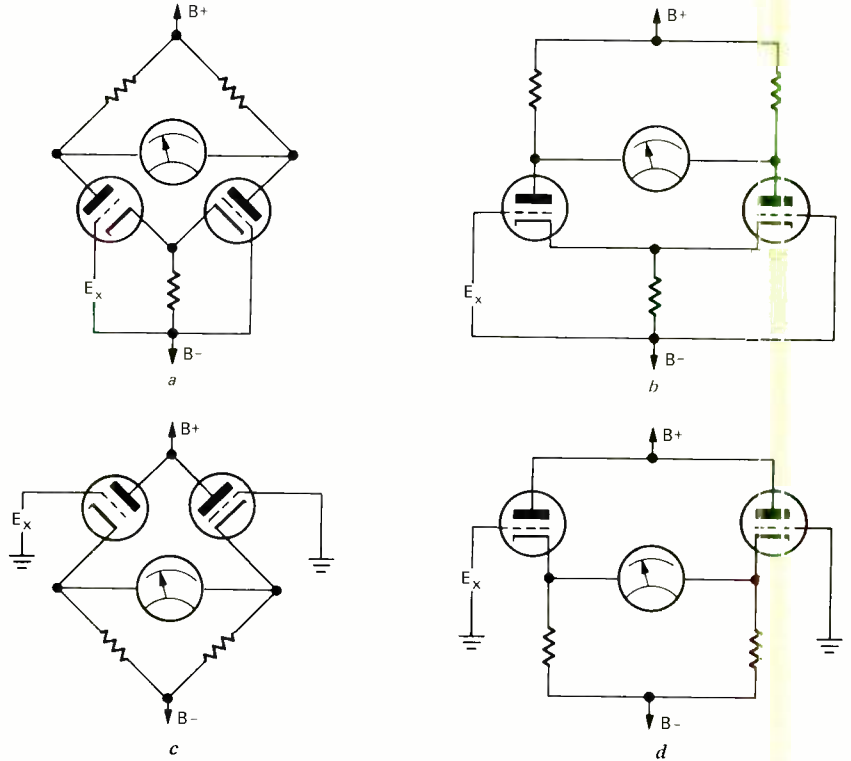

FIG. 2—TWO BASIC BRIDGE CIRCUITS of the VTVM. Each is drawn first as a bridge, then as a differential amplifier, with one of the inputs returned to common ground.

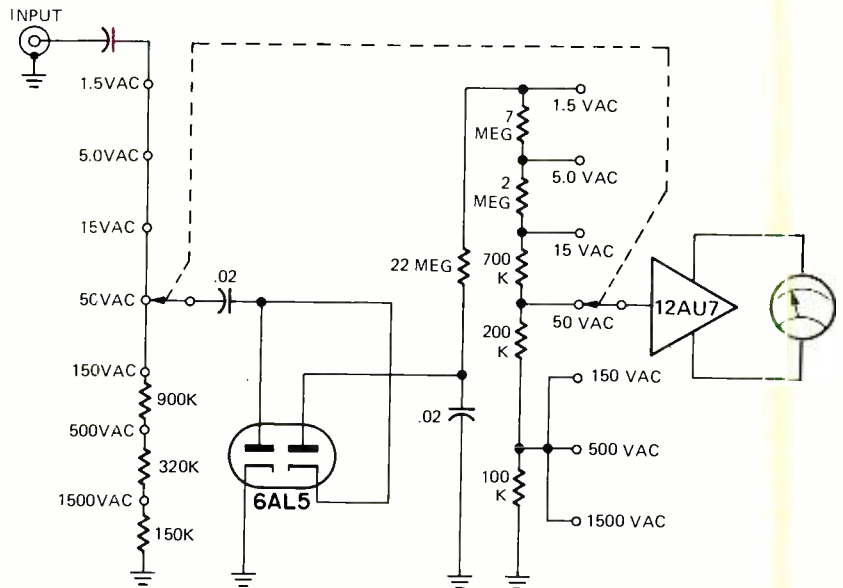

FIG. 3—A SIMPLIFIED SCHEMATIC of the AC portion of the Heathkit model IM-18 vacuum tube voltmeter.

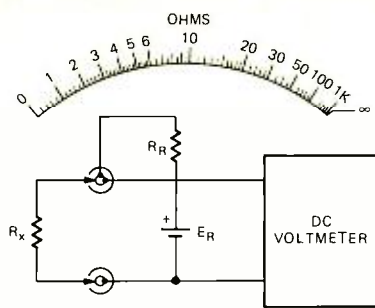

FIG. 4—BASIC OHMMETER CIRCUIT. Adjustments bring the meter to full scale with probes open-circuited.

require a specially calibrated meter scale. Signals in excess of 150 volts are attenuated, as higher voltages exceed the peak reverse voltage of commonly used rectifier tubes. The AC attenuator is not compensated when it is limited to a one-megohm total series impedance.

If either a 10-megohm attenuator or extended high-frequency response is required, the attenuator requires variable capacitors in parallel with the resistors. These capacitors are adjusted to ensure that the capacitive portion of the voltage divider is of the same ratio as the resistive portion. The capacitors provide the correct voltage division for high-frequency signals while the resistors provide the division for the low-frequency and DC signals.

The rectifier of the type shown in Fig. 3 has a DC output voltage proportional to the peak-to-peak value of the applied AC voltage. Most AC measurements, however, are made in terms of the RMS value of the signal. A voltage divider at the rectifier output reduces the peak-to-peak DC to a DC voltage equal to the RMS value of the rectified AC signal. Some VTVM's have a mode permitting direct display of peak-to-peak voltages. The RMS values are accurate only if the peak-to-peak to RMS ratio is 2.828—that is to say, if the input signal is a pure sine wave. Square, triangle and pulse waveforms give erroneous readings on the RMS scale, but read correctly on a peak-to-peak scale.

### The VTVM as ohmmeter

The common ohmmeter circuit for the VTVM is the voltage-divider type. In this circuit (Fig. 4) the meter scale has a non-linear calibration. The voltage across the unknown resistance ( $R_x$ ) is the ratio of the unknown resistance to the sum of the range resistor ( $R_R$ ) and the unknown resistor. Typically, the lowest resistance range uses a 10-ohm range resistor. With no resistance across the terminals, the voltmeter shows the open-circuit voltage of the battery. This point is calibrated as infinity on the ohmmeter scale. With a 10-ohm resistor connected to the terminals, half the battery voltage is displayed on the scale. Ten ohms is the center-scale reading of this meter. With a direct short across the terminals, the meter reads zero. When the ohmmeter is switched to the  $\times 100$  scale, the total series (range) resistance is increased to 100 ohms. This gives us a center-scale reading of 100 ohms. Each succeeding range of the ohmmeter increases the series resistance by a factor of 10. (Occasionally, other values of series resistance are used.)

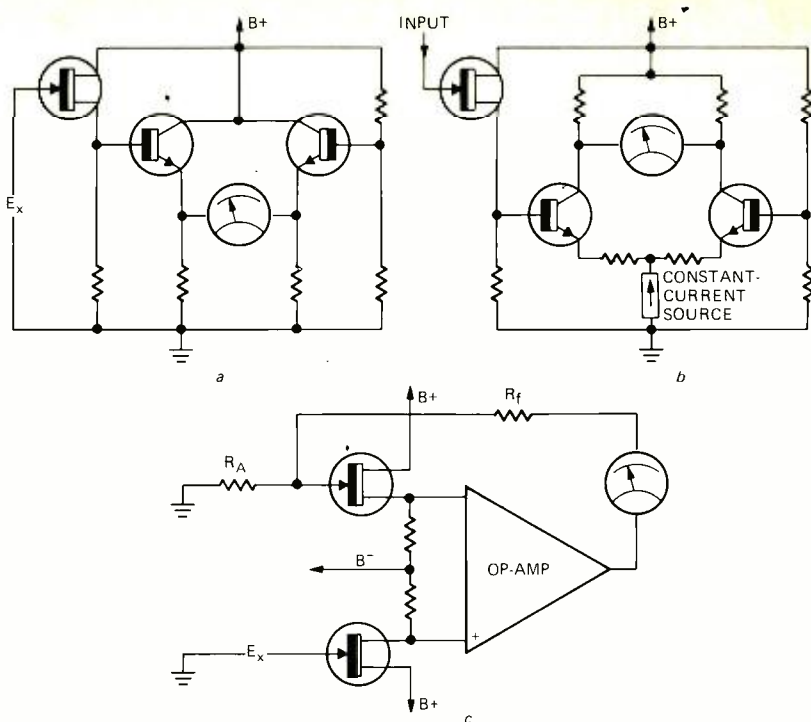

FIG. 5—THREE BASIC AMPLIFIERS for the VTVM. The Heathkit IM-17 VTVM is shown in a. The Heathkit IM-25 TVM is shown in b. It follows the classic VTVM bridge with gain. The Heathkit IM-104 TVOM, using an operational amplifier is shown in c.

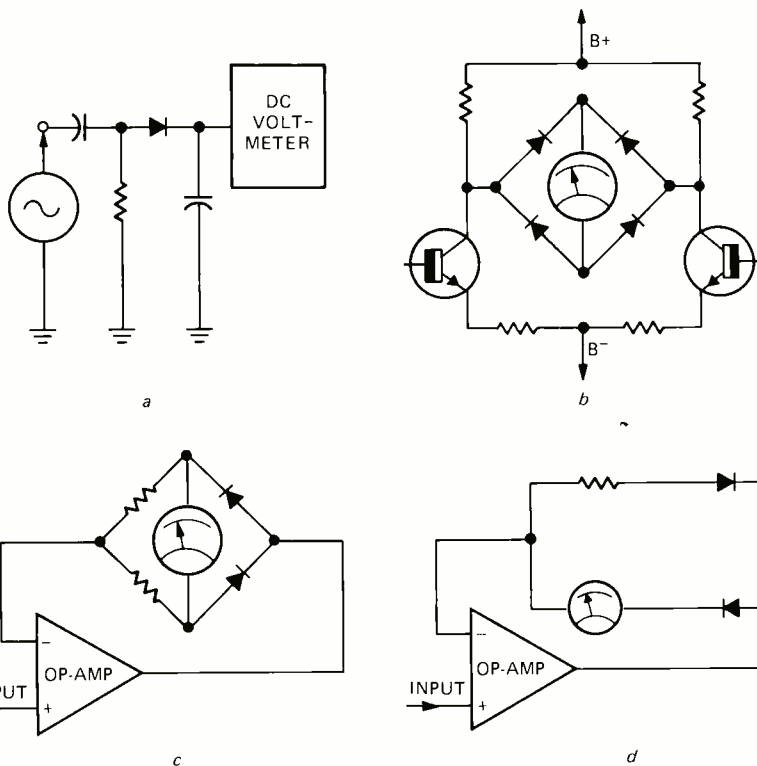

FIG. 6—FOUR TVM RECTIFIER CIRCUITS. Type used on very simple TVM's is shown in a. Rectifier is peak responding. A full-wave bridge used after the differential amplifier in b. Rectifier is average responding. Full-wave bridge used with the operational amplifier, also average responding, is shown in c. Another operational amplifier circuit is shown in d. Rectifier is half-wave and average responding.

### The TVM

The original TVM was nothing more than a solid-state version of the VTVM. Expanding knowledge has changed the design from the original simple one. Shown in Fig. 5 are three circuits used as the DC section of solid-state electronic multi-meters. Fig. 5-a is the simple balanced

bridge, characteristic of many VTVM's. In the solid-state version, the low impedance of the bipolar transistor loads a high-impedance attenuator. Consequently, a field-effect transistor is used as the input device. There is no gain in such a circuit, so TVM's of this type have a maximum  
(continued on page 82)



# How Noise is Measured in HI-FI

*Manufacturers measure signal-to-noise ratios differently. Before you compare, know the differences*

**LEN FELDMAN**  
CONTRIBUTING HI-FI EDITOR

THERE IS ONE SPECIFICATION RELATING TO high-fidelity equipment that has received increasing attention in recent years. That specification is noise, or more properly, signal-to-noise ratio. If one defines distortion as the presence of any signal in the output of a piece of equipment that is not present at the input, then noise is certainly a form of distortion. The only difference between harmonic or intermodulation distortion and "noise" is that harmonic and IM distortion consist of discrete identifiable frequencies whereas noise, as we commonly refer to it, contains varying amounts of random frequencies. It is generally agreed that noise that occurs outside the audio spectrum (above 20,000 Hz or below 20 Hz), while certainly within the broad definition of noise, is of no great concern. For this reason, noise measurements were originally made with low-pass and high-pass filters having cut-off points that eliminated the affects of noise beyond the limits of the audio spectrum.

## **Annoyance factor**

Recently, I received a letter from a reader who complained that he had been studying the specifications of two competing receivers that he was considering for his hi-fi system. Since his prime interest was in listening to records, he was particularly concerned with the phono signal-to-noise (S/N) ratio. Receiver "A" claimed a phono S/N ratio of 60 dB, while receiver "B" boasted a phono S/N ratio of 70 dB. Both specifications were referenced to an input signal level of 2.5 millivolts and both receivers had equal output power capability, so he was convinced that neither manufacturer was playing any

games by varying the input or output reference level. Convinced that receiver "B" would be his choice, he found a dealer who stocked both models and did some listening tests. Much to his surprise, receiver "B" had noticeably more hum (easily discernible during quieter passages of music on the record he was playing) than receiver "A". And hum certainly qualifies as one form of "noise", even if it does consist of discrete frequencies (usually 60 Hz and multiples thereof). Was the manufacturer of receiver "B" lying in his published specifications? Not at all. What the maker of receiver "B" had failed to specify is that his measurements were made using a "weighting network"—in this case, an "A" weighting network.

Long ago, researchers discovered that humans do not hear all frequencies at the same *audible* level when all frequencies are reproduced at equal measured intensity. The now familiar Fletcher-Munson curves reveals that particularly at low listening levels, we are less sensitive to extreme bass and extreme high frequencies. Since noise, in any reasonable piece of hi-fi equipment is reproduced at very low levels, it stands to reason that this "non-flat response" characteristic of human hearing would play an important role in evaluating the annoyance factor of noise. As an example, 60-Hz hum reproduced at 60-dB below some arbitrary loud listening level *should* be less annoying to a listener than a 1000-Hz tone reproduced at the same level. Similarly, a hissing type of noise containing primarily frequencies over 10,000 Hz should be less audibly annoying than high-frequency noise centered at around 5,000 Hz or so. These considerations gave rise to the first three types of "weighting networks" that are common-

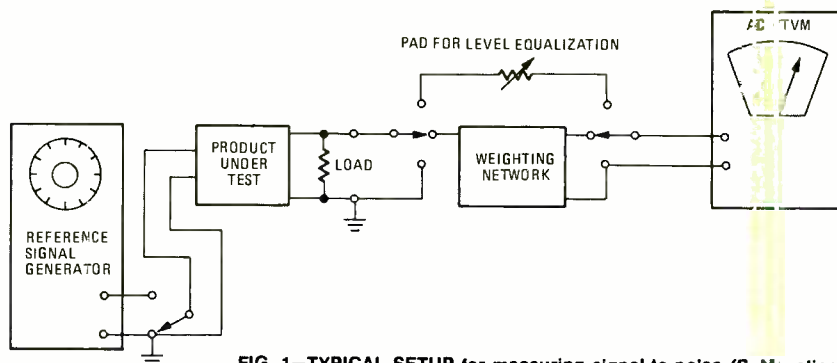

FIG. 1—TYPICAL SETUP for measuring signal-to-noise (S/N) ratios.

ly used in acoustic and electrical noise measurements. The three weighting curves are known as "C" weighting, "B" weighting and "A" weighting. They were standardized by the American National Standards Institute (ANSI). When making noise measurements, the weighting networks are inserted between the output of the device being measured and an average-reading AC voltmeter. The setup is shown in Fig. 1. A reference output level is first established by applying some known input to the device. This reference output level is very often the rated output of the device being tested. The signal is then removed from the input, the input is grounded and the weighting network is inserted between the output of the device being tested and the AC meter. If the network has an insertion loss, this loss must be taken into account when the noise reading is taken. The noise read on the voltmeter is then expressed as "so many dB below the reference output" and, for a complete description of the measurement, the words "A Weighted" (or "B", or "C") should be added.

## **ABC's of weighting networks**

The standard "C" network has a frequency response with a continuous roll-off above 10,000 Hz and below 20 Hz. This roll-off is at a rate of 6 dB-per-octave or greater.

The "B" weighting network is similar to the "C" network but with the addition of a simple high-pass network having its half-power (-3dB) point at 160 Hz.

The "A" network changes the response with respect to a "C" network by the same amount as two simple cascaded identical non-isolated resistor-capacitor high-pass networks, each having its half power (-3 dB) point at 280

Hz. The frequency response characteristics of each of these networks is plotted in Fig. 2.

Figure 3 shows a simple circuit that has the same frequency response as an "A" network. It is designed to operate from a 600-ohm source impedance and to be terminated at its output with at least a 1-meg ohm impedance of a vacuum-tube voltmeter.

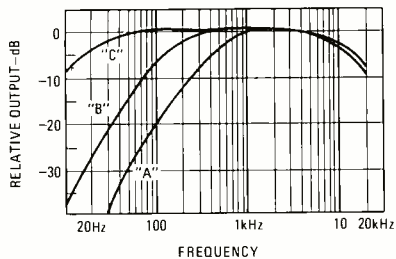

FIG. 2—STANDARD WEIGHTING CURVES commonly used in measuring signal-to-noise ratios.

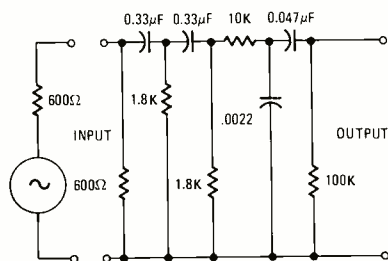

FIG. 3—"A" WEIGHTING CHARACTERISTIC is provided by simple passive circuit.

### Built-in noise weighting

The principle of interposing a specific frequency-response characteristic that is designed to lessen noise is familiar to anyone who has studied FM broadcasting standards. An FM receiver has a built-in low-pass R-C filter after the FM detector that attenuates frequencies above 1 kHz.

To illustrate the affects of the built-in low-pass filter, Fig. 4 shows two succes-

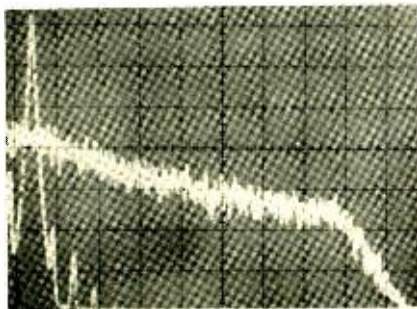

FIG. 4—NOISE FROM FM TUNER is attenuated at high-frequencies because of 75 microsecond de-emphasis.

sive sweeps of our spectrum analyzer. In this case, the sweep was linear and each box from left to right on the graticule represents a span of 2 kHz. The sharp peak at the left is our reference signal (1 kHz). For the second sweep, this signal was removed, and the signal strength was reduced to zero. The random noise

is shown to have decreasing amplitude with frequency when measured from the main output of the tuner because we are measuring the noise after the signal has passed through the so-called 75-microsecond de-emphasis network. It is down some 14 dB or so at 10 kHz (mid-trace).

Next, we connected our measurement setup directly to the detector output of the same tuner (ahead of the de-emphasis network) and again repeated the two sweeps, making sure that our reference 1-kHz tone was at the same relative level as before. Disregarding the lower sweep (that resulted from residual noise in our measurement system), you will note that the noise (at the center of the scope face, vertically) has an almost constant amplitude from 0 to 20,000 Hz. Clearly, if both the de-emphasized output in the case of Fig. 4 and the "flat" output of Fig. 5 were read as a

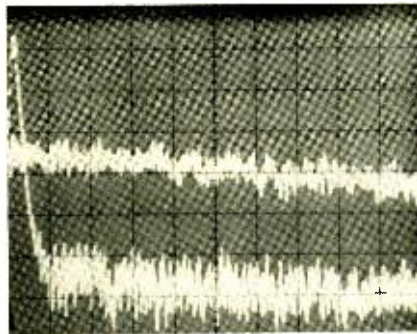

FIG. 5—NOISE FROM FM DETECTOR has almost constant amplitude due to the lack of de-emphasis.

single measurement on a VTVM, the reading in the case of the "flat" output would be many dB greater than that of the de-emphasized noise output.

### The "A" weighting curve

Shown in Fig. 6 is another dual-sweep presentation on our spectrum analyzer.

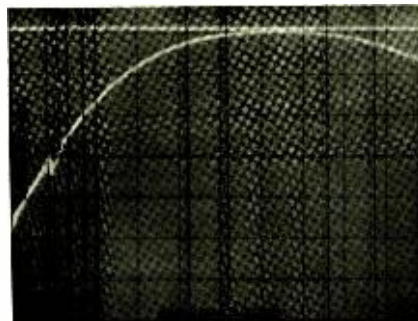

FIG. 6—ACTUAL "A" WEIGHTING network frequency response.

The horizontal line at the top is a reference level sweep from 20 Hz to 20,000 Hz. This time the spectrum analyzer is set for a logarithmic sweep. Each octave takes up the same amount of space from left to right, the way we are most accustomed to examining an audio frequency response. The superim-

posed curved response is that obtained by inserting the "A" network of Fig. 3 between the swept-frequency signal source and the spectrum analyzer's input that was adjusted to take into account the insertion losses of the filter network. Compare this curve with the hand drawn plot of the official "A" weighting characteristic of Fig. 2. Note that at 60 Hz, response of the network itself is down some 40 dB, while at 120 Hz it is down approximately 15 dB (each vertical division on the scope face equals a 10-dB change in amplitude).

In any noise measurements using an "A" weighting network, hum components will not contribute to the "single reading" on a voltmeter. Only noise in the region from around 500 Hz to 10 kHz will determine what the averaging-VTVM will read. If a given piece of equipment had substantial noise above 10 kHz, this component of noise would also be attenuated by the roll-off action of the network above 10 kHz. The shape of the "A" weighting response curve was designed to correspond with what many researchers believed to be the "annoyance" factor of noise rather than with its absolute amplitude.

### Annoyance factor

More recently, studies have suggested that the so-called "annoyance factor" of noise does not necessarily correspond with the "equal loudness" curves of the old Fletcher-Munson studies. The more recent DIN network differs somewhat from the "A" weighting network in that it includes a sharp cut-off filter above 9 kHz. Recent developments in audio have extended the bandwidth of hi-fi equipment to well beyond 15 kHz, and many audiophiles now believe that a "correct" weighting network (that will truly correlate annoyance factor with metered noise readings) must be capa-

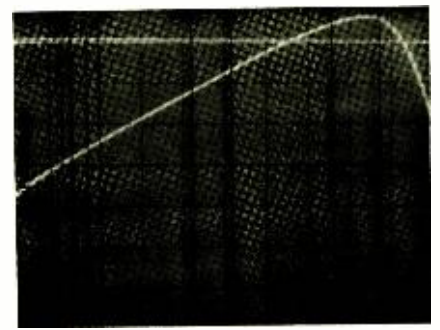

FIG. 7—CCIR WEIGHTING NETWORK frequency response.

ble of taking extreme high-frequency noise into account.

One such network is known as the CCIR weighting network and its characteristics are shown in Fig. 7 using the same double-sweep method used in Fig. 6. Two things are particularly interesting about this curve. Notice that in the



region above 2 kHz and extending to about 12 kHz, the curve actually *emphasizes* noise contained in that bandwidth. In other words, this network implies that noise at around 3 to 6 kHz, if present in a system, is actually *more* annoying (and should be given greater emphasis in any measurement) than program information contained in that same region of frequencies. The other difference between the "A" weighting network and the CCIR network is that attenuation in the newly proposed weighting network occurs at a higher frequency at the high end of the spectrum.

Comparing the frequency response of the "A" network (Fig. 6) with the new CCIR network (Fig. 7) reveals that for frequencies below 2 kHz, the CCIR network de-emphasizes noise contributions to a greater degree than does the "A" network while for frequencies between 2 kHz and 15 kHz, noise contributions within that range are emphasized with respect to the "A" network. Clearly, the CCIR network is going to reveal those hi-fi-products that have high-frequency hiss or noise as having poorer S/N ratios than will the "A" curve, while those products that have a somewhat greater noise contribution at low frequencies will yield a poorer overall S/N figure when measured with an "A" network than when measured with the CCIR network.

Since noise measurements of tape and tape decks are concerned more with tape hiss than with hum and low frequency noise, the CCIR method would seem to lend itself particularly to such measurements. To illustrate this, we altered the sweep of our spectrum analyzer so that it would sweep linearly (so that the high-frequency region would not be as compressed as it is in log sweep and would therefore be easier to analyze in detail), so that one horizontal division equals a sweep of 2000 Hz (beginning at 0 Hz at the left). Using a high-quality cassette deck, we first established a reference level below which the noise was to be measured

using no weighting network whatever, as shown in Fig. 8. We then recorded a

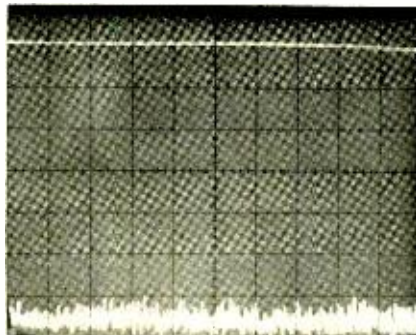

FIG. 8—TAPE NOISE from cassette deck measured with no weighting network.

no-signal condition on the tape for some sufficient time and played back the "noise" for our second sweep (lower sweep of Fig. 8). Noise level is practically constant over the entire range of sweep.

Next, we inserted the "A" weighting network between the output of the tape deck and the spectrum analyzer and repeated the two sweeps. The upper sweep of Fig. 9 shows the characteristic

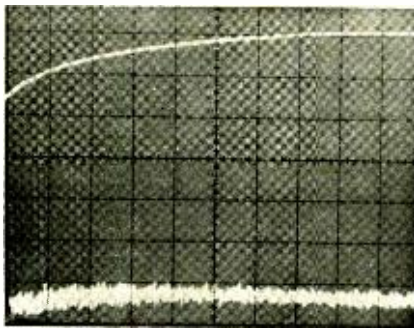

FIG. 9—TAPE NOISE from cassette deck measured with "A" weighting network.

of the "A" network, while the lower sweep exhibits diminished noise at the low-frequency end of the spectrum. Finally, we inserted the new CCIR network and repeated the same measurement, after first establishing the same flat reference level as before.

Figure 10 shows that the noise spectrum follows the response of the CCIR network and, in fact, the noise content from about 4 kHz to 12 kHz is actually emphasized by the action of the active CCIR network while it is steeply attenuated at the high end of the spectrum (above 15 kHz) and less severely attenuated at the low end.

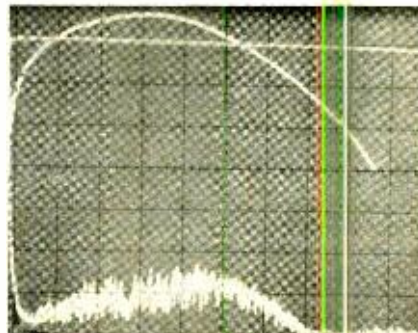

FIG. 10—TAPE NOISE from cassette deck measured with CCIR weighting network.

If the CCIR method were to be adopted universally for audio noise measurements, according to its proponents (which include Dolby Laboratories) there would be closer correlation between the readings obtained on an average reading VTVM and the annoyance factor of the noise, making for a more meaningful comparison between similar products. Of course, any measurement of hum would be meaningless using this system, and one would have to revert back to the "C" weighting network for such measurement.

The important thing to note about all this is that unless the industry adopts a uniform method of noise measurements, one manufacturer's 60-dB S/N ratio may or may not be as good as another's. So long as that is true, we really have no meaningful way in which to compare this important specification when considering the purchase of a piece of hi-fi equipment—whether a tuner, a receiver, a tape deck or an amplifier. **R-E**

## Electronic technicians honor two outstanding members

The NESDA Man of the Year Award was this year presented—for the first time—to two members: Dick Pavek, President of Tech Spray, Amarillo, TX, and Miles Sterling, owner of Electro TV, Garden Grove, CA.

Mr. Pavek was cited for his outstanding efforts on behalf of the Certified Electronics Technician (CET) program of the Association. His firm, Tech Spray, this year underwrote a substantial portion of an individual's CET test fee.

Miles Sterling was cited for his vigorous and courageous efforts on behalf of independent consumer electronics service dealers. It was Miles who initiated the \$6 million lawsuit against several large electronics manufacturers, charging illegality

in the method of handling warranty payments to independent service dealers. Besides waging war on the giants, he spent many weeks and much personal effort in working for the passage of California Senate Bill 568, which will eliminate inequities in the California warranty practices law that have given trouble to independent service technicians.

Awards were also given to a number of members and association officers:

**NESDA Outstanding Officer**, to Leroy Ragsdale, Ft. Smith, AR, who was President last year.

**NESDA Outstanding Committee Chairman**, to Paul F. Dontje, CET, Arvada, CO, Chairman of NESDA's Business Management Committee.

**The Hal Chase Memorial Award**, presented to the outstanding state Association president, to John Cioni, president of NESDA's fastest growing organization, the Arizona State Electronics Association. **The Jack Betz Memorial Award**—in honor of the year's outstanding local association president—to Cliff Lum of Honolulu, past president of HESDA of Hawaii.

An award for the outstanding state association publication went to the *OTSA News Channel*, Salem, OR; Al Lamer, CET, Editor. The award for the outstanding local association publication was won by *ARTSD News*, Columbus, OH; Don Blazer, CET, Editor. The award winners were selected by the editorial staff of *Radio-Electronics* magazine.

# Be the “New Professional” in electronics

**CREI trains you at home  
for one of the most important  
career levels in electronics —  
plus offers you special  
arrangements for engineering  
degrees**

Most people think there are only two levels of careers in electronics: the technician level and that of the degree engineer.

There is, however, a third and very important level. It is that of the engineering technician or *practical* engineer. The growing importance of this career level has created what might well be called the “New Professional” in electronics.

If you look at the various levels of employment in electronics, you will understand why this “New Professional” is so important.

The average technician is a person who has had vocational training in electronics. He understands the basic principles of electronics so he can troubleshoot, repair and maintain equipment. He usually works under close supervision in performing his duties.

The engineer has college training in electronics. He usually supervises technician personnel and is responsible for planning and developing of electronic equipment and systems. Frequently, however, engineers are more heavily trained in the scientific principles of electronics and less in their practical application.

The engineering technician, by contrast, is a specialist in the practical application of electronics. His training usually consists of a two-year college program in electronic engineering technology. In many organizations, the engineering technician handles several of the responsibilities of the degree engineer. He often has the title of engineer.

CREI programs are designed to give you at home the same level and depth of training you receive in a two-year college program in electronic engineering technology. CREI programs are, in fact, more extensive than you will find in many colleges. And CREI gives you the opportunity to specialize in your choice of the major fields of electronics.

## **Unique Design Lab**

CREI gives you both theory and practical experience in circuit design with its Electronic Design Laboratory Program. The professional equipment included in this program allows you to construct, test out and correct the circuits you design until you have an effective circuit.

This Lab Program helps you understand advanced electronics. It also gives you practical experience in many other important areas of electronics, as in pro-



# Career Training at Home

totype construction, breadboarding, test and measurement procedures, circuit operation and behavior, characteristics of electronic components and how to apply integrated circuits.

Only CREI offers the unique Lab Program. It is a complete college Lab and, we believe better than you will find in most colleges. The "Lab" is one of the factors that makes CREI training interesting and effective. And the professional equipment in this program becomes yours to keep and use throughout your professional career after you complete the training.

## Engineering Degree

CREI offers you special arrangements for earning credit for engineering degrees at certain colleges and universities as part of your home study training program. An important advantage in these arrangements is that you can continue your full time job while "going to college" with CREI. This also means you can apply your CREI training in your work and get practical experience to qualify for career advancement.

## Wide Program Choice

CREI gives you a choice of specialization in 14 areas of electronics. You can select exactly the area of electronics best for your career field. You can specialize in such areas as computer electronics, communications engineering, microwave, CATV, television (broadcast) engineering and many other areas of modern electronics.

## Free Book

In the brief space here, there isn't room to give you all of the facts about CREI college-level, home study programs in electronics. So we invite you to send for our free catalog (if you are qualified to take a CREI program). The catalog has over 80, fully illustrated pages describing your opportunities in advanced electronics and the details of CREI home study programs.

## Qualifications

You may be eligible to take a CREI college-level program in electronics if you are a high school graduate (or the true equivalent) and have previous training or experience in electronics. Program arrangements are available depending upon whether you have extensive or minimum experience in electronics.

# Send for this FREE Book describing your opportunities and CREI college-level programs in electronics

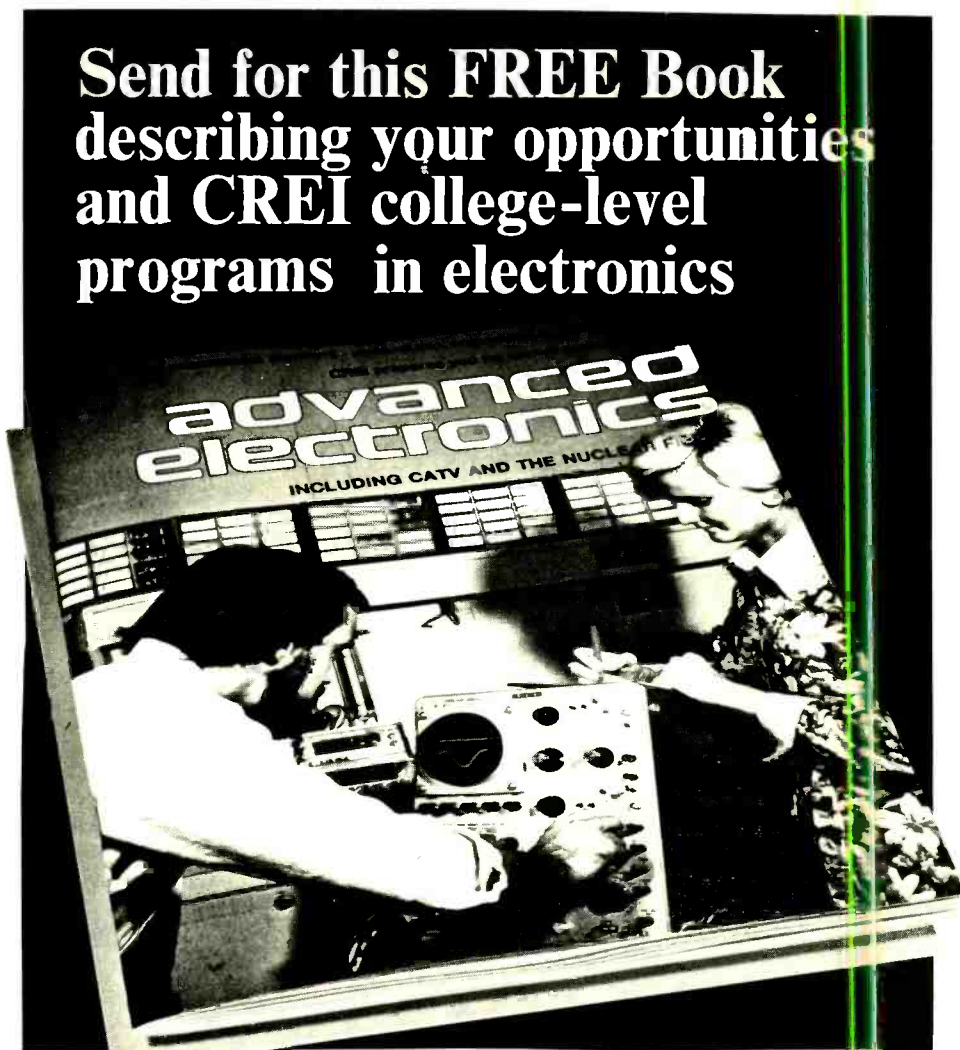

Mail card or write describing qualifications to

**CREI** **CAPITOL  
RADIO  
ENGINEERING  
INSTITUTE**

McGraw-Hill Continuing Education Center  
3939 Wisconsin Avenue Northwest  
Washington, D.C. 20016

Accredited Member National Home Study Council

## GI Bill

*CREI programs  
are approved  
for training of  
veterans and  
servicemen under  
the G.I. Bill*



# Radio-Electronics

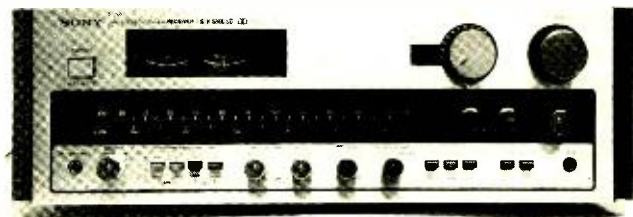

## Tests Sony STR-6800SD Receiver

1

LEN FELDMAN

CONTRIBUTING HI-FI EDITOR

UNLIKE MANY OF THE MAJOR HIGH-FIDELITY component receiver manufacturers, Sony Corporation had, for several years, refrained from "model changes" every few months. They preferred to keep their receiver product line intact for the past three years or so. Now, in a major redesign sweep, Sony has come up with three new receivers ranging in suggested retail price from \$400 to \$600. The highest-powered (and highest priced) of these is their new model *STR-6800SD*, shown in Fig. 1, and this new receiver looks completely different from earlier Sony models. The front panel controls, dial layout and metering arrangement have been completely reshuffled for what, in our opinion, is a much more logical grouping of functions.

The most often used volume and tuning control knobs are together at the upper right of the panel, with the click-stop detented volume control flanked by a handy 20 dB audio muting switch. A rectangular power on/off pushbutton and signal-strength and center-of-channel tuning meters are at the upper left, with the signal meter doubling as a multipath indicator. To the right of the meters are Dolby and stereo FM indicator

lamps. The dark-colored dial area across the center section of the panel has a linear FM scale with markings at every 200 kHz and a less accurately defined AM scale. An illuminated pointer travels along an opening between these scales and increases in illuminated length when a station is tuned in accurately. Quite a startling effect when you see it happen for the first time! To the right of the dial scales are TAPE and MONITOR selector switches and a five-position program SELECTOR switch. The combined use of the TAPE and MONITOR switches permit copying from one tape deck to the other, in any direction, plus monitoring of either deck connected to the receiver.

Along the lower edge of the two-tone dial area are located the HEADPHONE jack, SPEAKER selector switch (up to three pairs of speakers can be connected, with up to two switchable for simultaneous listening in two locations), LOW FILTER and HIGH FILTER switches, dual concentric BASS and TREBLE controls (for independent adjustment of left and right channels), BALANCE control, ACOUSTIC COMPENSATION switch (with settings for fixed bass boost, loudness compensation or mid-band "presence" emphasis), FM MUTING switch, DOLBY FM switch, MULTIPATH switch (which alters the function of the signal

strength meter, as previously mentioned), MONO/STEREO switch, EXTERNAL adaptor switch and an AUX input phone jack that parallels the AUX input jacks located on the rear panel.



A view of the rear panel is shown in Fig. 2. Connections are provided for 75- or 300-ohm FM antennas as well as an external AM antenna. The usual input and output jacks for PHONO 1, PHONO 2, AUX, TAPE 1 and TAPE 2 are logically arranged, as are the in and out jacks for connection of an extra adaptor. A chassis-ground terminal is located just below the phono inputs and directly above the pivotable AM ferrite bar antenna. An FM discriminator output jack is provided for future use with a possible 4-channel FM adaptor. The three sets of speaker terminals are of the spring-loaded "piano key" type that accept stripped ends of speaker wires without the need of any tools. Three convenience AC outlets are also provided on the rear panel. Figure 3 illustrates the variety of components that may be connected to and used with the Sony *STR-6800SD* receiver.

The internal layout of the receiver is shown in Fig. 4. The entire front end, IF circuitry, AM circuitry, stereo decoder and Dolby decoding circuitry are all wired on a single large PC board, which also includes the 4-gang FM and 2-gang AM tuning capacitor. A heat-sink structure can be seen in the photo running across the full width of the chassis, near the rear. An MOSFET is used in the RF section of the FM front-end. A phased-locked-loop circuit is used for the stereo multiplex decoding section, and IC's are used for the built-in Dolby decoding circuitry. Tone controls are of the negative feedback type. The power-amplifier section is equipped with an electronic protection circuit as well as with a relay system which interrupts signal flow to the loudspeaker terminals in the event of an overload or shorted condition. This relay also delays receiver turn-on for a few seconds to permit power-supply voltages to reach stable values.

### FM measurements

A summary of measurements made for the

### MANUFACTURER'S PUBLISHED SPECIFICATIONS:

#### FM TUNER SECTION

**IHF Usable Sensitivity:** mono, 1.7  $\mu$ V. **50-dB Quieting Sensitivity:** mono, 3.5  $\mu$ V; stereo, 45  $\mu$ V. **S/N Ratio:** mono, 73 dB; stereo, 68 dB. **Harmonic Distortion:** 1 kHz: mono, 0.2%, stereo, 0.3%. 100 Hz: mono, 0.2%, stereo, 0.3%. 10 kHz: mono, 0.2%, stereo, 0.6%. **Intermodulation Distortion:** mono, 0.2%; stereo, 0.3%. **Frequency Response:** 30 Hz–15 kHz, +0,–1.5 dB. **Capture Ratio:** 1.0 dB. **AM Suppression:** 54 dB. **Image Rejection:** 75 dB. **IF Rejection:** 100 dB. **Spurious Rejection:** 100 dB. **Subcarrier and SCA Rejection:** 60 dB. **Muting Threshold:** 5.0  $\mu$ V. **Stereo Separation:** 40 dB at 1 kHz; 35 dB at 100 Hz; 35 dB at 10 kHz.

#### AM TUNER SECTION

**Usable Sensitivity:** 250  $\mu$ V internal antenna; 100  $\mu$ V external. **S/N Ratio:** 50 dB. **Selectivity:** 35 dB. **Image Rejection:** 40 dB. **IF Rejection:** 35 dB. **THD:** 0.5%

#### AMPLIFIER SECTION

**Power Output:** 80 watts continuous per channel, 8 ohm loads, 20 Hz to 20 kHz. **Rated THD:** 0.15%. **IM Distortion:** 0.15% at rated power. **Damping Factor:** 40 at 8 ohms. **Input Sensitivities:** Phono 1 & 2: 2.5 mV; Aux, Tape and Adaptor: 250 mV. **Signal-to-Noise Ratios:** ("A" weighted) Phono: 72 dB; High Level 90 dB. **Frequency Response:** Phono: RIAA:  $\pm$  0.5 dB; High Level: 10 Hz to 30 kHz, +0,–2 dB. **Tone Control Range:**  $\pm$  10 dB at 100 Hz (bass) and 10 kHz (treble). **High and Low Filters:** 6 dB-per-octave at 5 kHz, 10 kHz, 50 Hz and 25 Hz.

#### GENERAL SPECIFICATIONS

**Dimensions:** 19 $\frac{1}{4}$  W  $\times$  6 $\frac{9}{16}$  H  $\times$  16 $\frac{1}{4}$ -inches D. **Weight:** 36 $\frac{1}{2}$  lbs. **Power Consumption:** 225 watts (max), 120 V, 60 Hz. **Suggested Retail Price:** \$600.00.

FOR MANUFACTURER'S LITERATURE, CIRCLE 61 ON FREE INFORMATION CARD



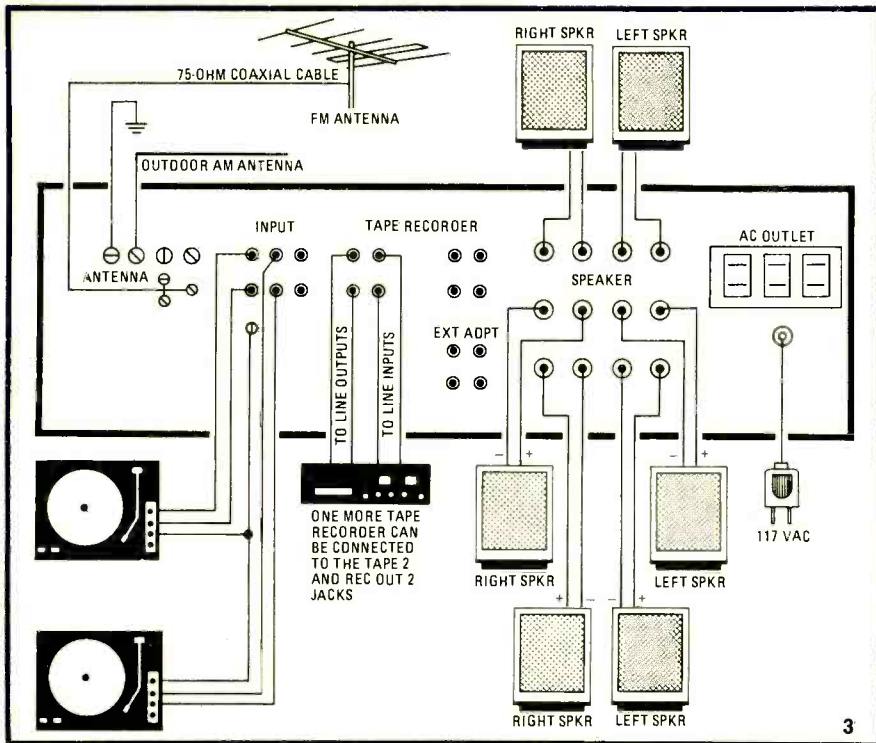

receiver the better. Even Sony makes no great sensitivity claims for this circuit. (100  $\mu\text{V}$  of usable sensitivity, using the external antenna terminal, compares very poorly with 15, 20 and 30  $\mu\text{V}$  figures normally obtained for AM circuits included in higher priced receivers). No doubt, this is another area in which compromises were needed to achieve the price goal while retaining more important circuit features and power capability in the amplifier section.

We verified the performance of the Dolby decoding circuitry by listening to at least two FM stations in our area that broadcast Dolby regularly and the usual improvement in noise reduction and dynamic range was evident. We also verified the fact that the de-emphasis at the output of the tuner section is changed from 75 microseconds to 25 microseconds automatically when the Dolby push button switch is depressed. This is confirmed in the two frequency-sweep traces in the scope photo of Fig. 5. The upper trace is the de-emphasis response at 25  $\mu\text{s}$  while the lower trace shows the roll-off characteristic needed to compensate for broadcast pre-emphasis of 75 microseconds. Note the steep drop-off at 19 kHz—a desirable characteristic caused by the low-pass filters built into the multiplex decoder output circuits to improve sub-carrier product rejection.

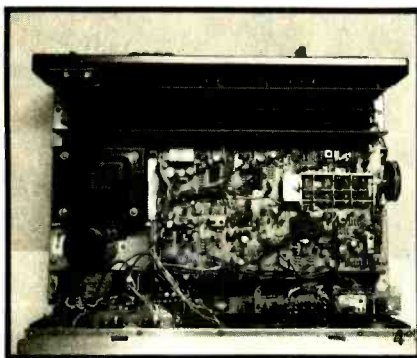

FM tuner section will be found in Table I, together with our comments regarding those measured results as they relate to a receiver in this price and power category. While FM measurements were, for the most part, excellent, it is obvious that in order to reach this selling price certain design compromises and trade-offs had to be made, particularly in the area of such secondary specifications as AM suppression ratio, alternate channel selectivity and stereo distortion. Receivers in this power and price category from some other manufacturers have had better, overall tuner sections than the one engineered into this Sony receiver. On the other hand, many of the competitive models have higher price tags and lack the Dolby decoding feature that is generally conceded to be worth around an extra 100 dollars if bought separately.

Stereo separation, on the other hand, was extremely good and stable, and stereo threshold and muting threshold were just where we like to see them. Tuning meter indications agreed perfectly with minimum-distortion tuning points, and dial calibration was never off by more than a pointer-width. The multipath indicating function of the signal-strength meter worked well. (We were able to test it by using the rotator connected to our outdoor antenna and orienting the antenna for minimum indication on this meter).

The less said about the AM section of the

**TABLE I**  
**RADIO-ELECTRONICS PRODUCT TEST REPORT**

Manufacturer: **Sony**

Model: **STR-9800SD**

**FM PERFORMANCE MEASUREMENTS**

	R-E Measurement	F-E Evaluation
<b>SENSITIVITY, NOISE AND FREEDOM FROM INTERFERENCE</b>		
IFH sensitivity, mono ( $\mu\text{V}$ )(dBf)	1.7 (9.8)	Excellent
Sensitivity, stereo ( $\mu\text{V}$ )	4.0 (17.2)	Good
50-dB quieting signal, mono ( $\mu\text{V}$ )	2.8 (14.1)	Very Good
50-dB quieting signal, stereo ( $\mu\text{V}$ )	33 (35.6)	Average
Maximum S/N ratio, mono (dB)	72	Very good
Maximum S/N ratio, stereo (dB)	68	Excellent
Capture ratio (dB)	1.2	Excellent
AM suppression (dB)	55	Good
Image rejection (dB)	75	Average
IF rejection (dB)	100 +	Superb
Spurious rejection (dB)	100 +	Superb
Alternate channel selectivity (dB)	73	Good
<b>FIDELITY AND DISTORTION MEASUREMENTS</b>		
Frequency response, 50Hz to 15 kHz ( $\pm$ dB)	+0, -2.0	Fair
Harmonic distortion, 1kHz, mono (%)	0.15	Good
Harmonic distortion, 1kHz, stereo (%)	0.20	Very good
Harmonic distortion, 100 Hz, mono (%)	0.19	Good
Harmonic distortion, 100 Hz, stereo (%)	0.33	Fair
Harmonic distortion, 6 kHz, mono (%)	0.15	Very good
Harmonic distortion, 6 kHz, stereo (%)	0.30	Excellent
Distortion at 50-dB quieting, mono (%)	1.2	Fair
Distortion at 50-dB quieting, stereo (%)	0.35	Good
<b>STEREO PERFORMANCE MEASUREMENTS</b>		
Stereo threshold ( $\mu\text{V}$ ) (dBf)	3.3 (15.6)	Very good
Separation, 1 kHz (dB)	44.0	Excellent
Separation, 100 Hz (dB)	42.0	Excellent
Separation, 10 kHz (dB)	33.0	Excellent
<b>MISCELLANEOUS MEASUREMENTS</b>		
Muting threshold ( $\mu\text{V}$ )	4.0	Good
Dial calibration accuracy ( $\pm$ kHz @ MHz)	0.2	Excellent
<b>EVALUATION OF CONTROLS, DESIGN, CONSTRUCTION</b>		
Control layout		Very good
Ease of tuning		Very good
Accuracy of meters or other tuning aids		Excellent
Usefulness of other controls		Very good
Construction and internal layout		Good
Ease of servicing		Good
Evaluation of extra features, if any		Excellent
<b>OVERALL FM PERFORMANCE RATING</b>		<b>Very good</b>

## Amplifier measurements

Table II summarizes the measurements made on the preamplifier and power amplifier sections of the STR-6800SD receiver. It is obvious from these results that the power amplifier section is conservatively rated and has extremely low harmonic-distortion at output power levels up to its rated value and

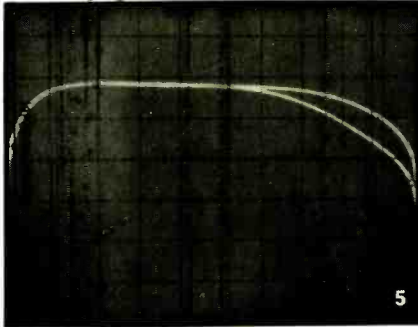

beyond. Though IM distortion was a bit higher at rated output, it was nevertheless still below the rated figure of 0.15% and decreased substantially for all lower power values.

While our measured hum-and-noise figures in phono seem to be "just on the borderline (compared to published specifications), bear in mind that Sony lists these specifications on the basis of an A-weighting curve (which tends to de-emphasize the hum contribution), whereas our measurement is an unweighted one that measures wideband noise from 20 Hz to 20 kHz, including all hum components. In unweighted terms, the 71 to 72 dB figures obtained are excellent. Phono overload of 100 millivolts was deemed adequate if not outstanding and should cause no problem with cartridges having nominal outputs up to about 5 mV or so (which accounts for most popular cartridges with which the receiver is likely to be used).

Range of bass and treble controls is plot-

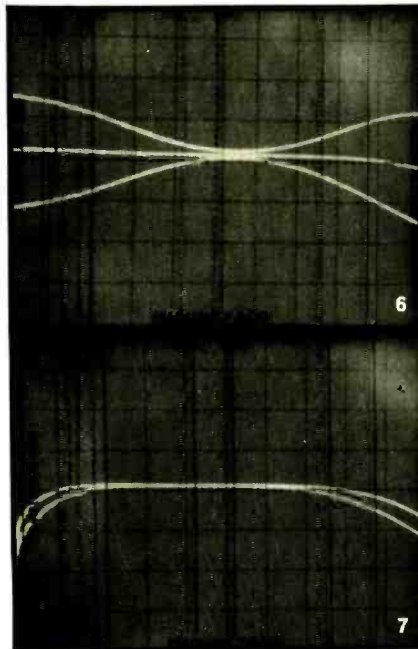

ted, by means of our spectrum analyzer, in the scope photo of Fig. 6, while the action of the selectable low-cut and high-cut filters is shown in Fig. 7.

We also measured the response of the

### TABLE II

## RADIO-ELECTRONICS PRODUCT TEST REPORT

Manufacturer: **Sony**

Model: **STR-6800SD**

### AMPLIFIER PERFORMANCE MEASUREMENTS

	R-E Measurement	R-E Evaluation
<b>POWER OUTPUT CAPABILITY</b>		
RMS power/channel, 8-ohms, 1 kHz (watts)	93.1	Excellent
RMS power/channel, 8-ohms, 20 Hz (watts)	86.0	Excellent
RMS power/channel, 8-ohms, 20 kHz (watts)	90.0	Excellent
RMS power/channel, 4-ohms, 1 kHz (watts)	N/A	---
RMS power/channel, 4-ohms, 20 Hz (watts)	N/A	---
RMS power/channel, 4-ohms, 20 kHz (watts)	N/A	---
Frequency limits for rated output (Hz-kHz)	16-25	Excellent
<b>DISTORTION MEASUREMENTS</b>		
Harmonic distortion at rated output, 1 kHz (%)	0.028	Superb
Intermodulation distortion, rated output (%)	0.115	Good
Harmonic distortion at 1 watt output, 1 kHz (%)	0.025	Excellent
Intermodulation distortion at 1 watt output (%)	0.020	Excellent
<b>DAMPING FACTOR, AT 8 OHMS</b>	40	Very good
<b>PHONO PREAMPLIFIER MEASUREMENTS</b>		
Frequency response (RIAA $\pm$ ___dB)	1.0	Fair
Maximum input before overload (mV)	100	Good
Hum/noise referred to full output (dB) (at rated input sensitivity)	71/72	Excellent
<b>HIGH LEVEL INPUT MEASUREMENTS</b>		
Frequency response (Hz-kHz, $\pm$ ___dB)	8-30, 3.0	Very good
Hum/noise referred to full output (dB)	88	Good
Residual hum/noise (min. volume) (dB)	90	Fair
<b>TONAL COMPENSATION MEASUREMENTS</b>		
Action of bass and treble controls	See Fig. 7	Good
Action of low frequency filter(s)	See Fig. 8	Good
Action of high frequency filter(s)	See Fig. 8	Fair
<b>COMPONENT MATCHING MEASUREMENTS</b>		
Input sensitivity, phono 1/phono 2 (mV)	2.5/2.5	
Input sensitivity, auxiliary input(s) (mV)	250	
Input sensitivity, tape input(s) (mV)	250	
Output level, tape output(s) (mV)	250	
Output level, headphone jack(s) (V or mW)	N/A, 8-10K ohm	
<b>EVALUATION OF CONTROLS, CONSTRUCTION AND DESIGN</b>		
Adequacy of program source and monitor switching		Very good
Adequacy of input facilities		Excellent
Arrangement of controls (panel layout)		Good
Action of controls and switches		Good
Design and construction		Excellent
Ease of servicing		Good
<b>OVERALL AMPLIFIER PERFORMANCE RATING</b>		Very good

### TABLE III

## RADIO-ELECTRONICS PRODUCT TEST REPORT

Manufacturer: **Sony**

Model: **STR-6800SD**

### OVERALL PRODUCT ANALYSIS

Retail price (suggested)	<b>\$600.00</b>
Price category	<b>Medium/high</b>
Price/performance ratio	<b>Very good</b>
Styling and appearance	<b>Excellent</b>
Sound quality	<b>Excellent</b>
Mechanical performance	<b>Good</b>

**Comments:** An intelligent rearrangement of the traditional control layout common to most receivers, as well as a new, two-tone framed looking panel treatment makes this new top-of-the-line receiver from Sony look a bit different from either the familiar "blackout" look, or the newer, all-light colored front-panel look which seems to have become popular of late. The included Dolby decoding circuitry makes the price of this powerful receiver even more attractive, although we wish that some means of calibration of the Dolby levels (such as a built-in test tone) would have been incorporated, since Dolby test-tones broadcast by stations are becoming increasingly less frequent. A first look at the insides of the chassis tends to be a bit disappointing, for the layout seems more like that of a mass-produced set, with a great deal of circuitry all on one major PC board and a fully exposed and unshielded RF section—tuning gangs and all. Despite this, however, measurements were not affected by this layout, and neither was actual performance. Power output is very conservatively rated, and pre-conditioning tests did not result in any thermal shut-down or undue heating of the heat-sink structures or power transformer of this receiver. The tape-copy selector switch, the ACOUSTIC COMPENSATOR switch and the front-panel aux input jack add extra versatility to this unit and provisions for an extra adaptor (for 4-channel decoders, graphic equalizers, etc.) mean that you can retain full use of both other tape monitoring functions even if and when these extras are added later.



ACOUSTIC COMPENSATOR switch positions at a -30 dB setting of the master VOLUME control. Under those conditions, the loudness compensation circuitry boosts bass frequencies by some 10-dB at 50-Hz and treble frequencies by a more moderate 3-dB at 10-kHz. When the LOW switch position is selected, only the bass is boosted, to the extent of around 9-dB at 50-Hz, while in the PRESENCE position, a very moderate 3-dB of boost is added at mid-frequencies, centered at around 1000 Hz. Unfortunately, Sony made no provision for

using BOTH loudness compensation and PRESENCE action at the same time. Such an option would have been desirable, since the purposes for each are different.

### Summary and listening tests

Our overall product analysis as well as our reactions to the listenability and ease of control use of the Sony STR-6800SD will be found in Table III. While we can certainly appreciate Sony's desire to offer a powerful receiver at an unusually attractive price, we

would almost wish that the company had devoted a bit more engineering effort to the tuner sections of the receiver, even if that would have meant raising the price somewhat. As the receiver now stands, just about everything that could have been offered at this price has been included and if "watts per dollar" is of prime concern, the STR-6800SD offers a very excellent cost/performance ratio. If you want more power, better tuner performance, or some of each, you'll just have to spend more money. R-E

# Yamaha B-2 Amplifier

IN THE DECEMBER 1975 ISSUE OF RADIO-Electronics we discussed the then new power FET's that had begun to find their way into audio amplifying equipment, notably Yamaha's model B-1, which is still very much a part of that company's amplifier line. Those interested in learning more about the theory and operation of power FET's (or, V-FET's, as they are called) may wish to refer back to that article. Now, Yamaha has come up with a lower powered amplifier using much of the same technology; their model B-2, shown in Fig. 1.



Dominating the black front-panel are a pair of peak-reading meters that are calibrated from -50 dB to +5 dB. Since there are two sets of input jacks and facilities for connection of two pairs of speakers on the B-2, the remaining pushbuttons to the right of the meters select which inputs are to be applied to the amplifier, which speakers are to operate and permit turning off of all speakers during level adjustment. The four rotary controls provide sensitivity adjustment to compensate for different speaker efficiencies. A toggle switch at the left of the panel turns the amplifier power on and off.

Figure 2 shows the rear panel of the B-2. A most unusual speaker cable connection terminal arrangement is provided. Speaker wires are inserted in exposed holes and tiny thumb-knobs are rotated (much like a screw head) until the wires are firmly and perma-

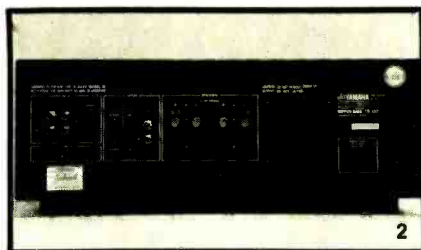

nently clamped. In addition to the two sets of input jacks (selectable from the front panel) there are two additional input jacks that permit using the front-panel meters either for power readings of other amplifiers or for voltage readings referenced to 0 dBm (0.775 volts).

Two adjacent switches determine whether the meters are to be used internally or exter-

nally and whether the meters are to be calibrated to read in watts across 8 ohms, or in terms of input voltage. Another slide switch near the input jacks (which are single-circuit phone-plug type rather than phono-tip jacks) selects between either a DC input or "normal" input. In the NORMAL position, DC-blocking capacitors are connected to the input but the input nevertheless maintains a flat response down to about 10 Hz. Yamaha suggests that the switch be set to the NORMAL position to prevent accidental application of a DC voltage to the input from preamplifiers or other program sources. In the DC position, the amplifier operates as a direct-coupled circuit from input to output.

An unswitched AC receptacle can be used for equipment that draws no more than 300 watts. Figure 3 illustrates how the B-2 would be incorporated in a complete high-fidelity

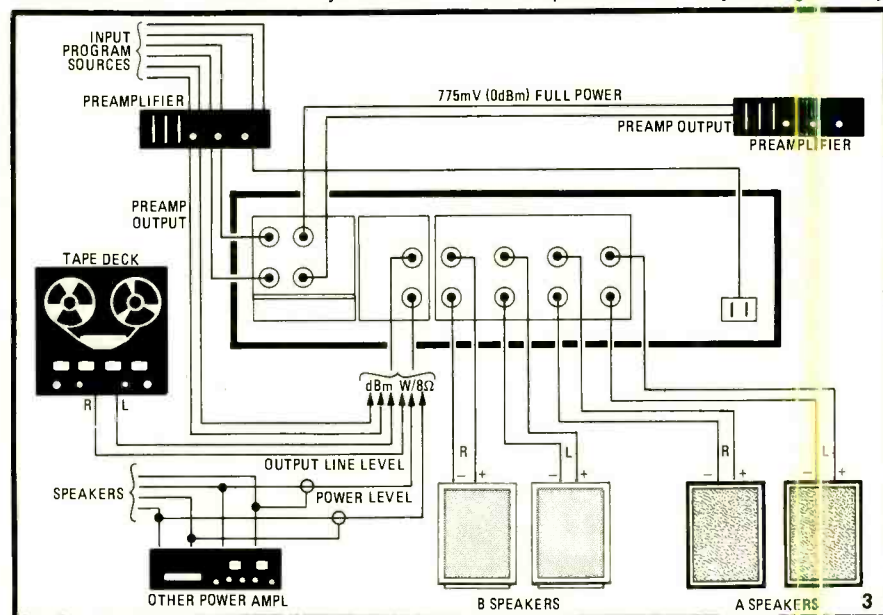

### MANUFACTURER'S PUBLISHED SPECIFICATIONS:

**Rated Power Output:** 100 watts per channel, 20 Hz to 20 kHz, with no more than 0.08% total harmonic distortion, 8 ohm loads (140 watts, 4 ohms). **IM Distortion:** 0.03%, at 50 watts, 4, 8 or 16 ohms. **Damping Factor:** 70 at 1 kHz. **Frequency Response** (1 watt, normal setting): 10 Hz to 100 kHz, +0, -1 dB. **Input Sensitivity:** 0.75 V. **Input Impedance:** 25,000 ohms. **Signal-To-Noise:** (IHF "A" Weighting): 115 dB. **Meter Range:** -50 to +5 dB (0 dB = 100W into 8 ohms, or 0 dBm). **Power Consumption:** 290 watts. **Dimensions:** 17 1/8 W x 6 H x 14 5/8-inches D. **Weight:** 57-lbs 3-oz. **Suggested Retail Price:** \$850.00.

component system. The second power amplifier shown illustrates how the meters might be used to monitor power output of another amplifier.

### Internal construction

As can be seen in the photo of Fig. 4, separate power transformers are used in each channel of the B-2. Massive heat sinks containing the parallel connected 2SK 76 and 2SJ26 (N-channel and P-channel) power V-

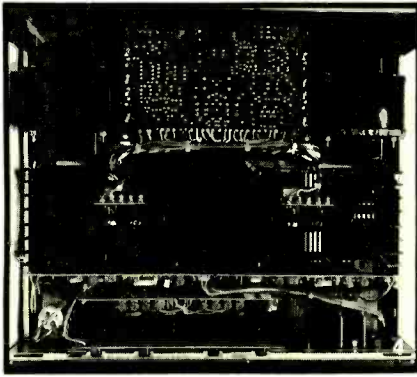

FET's are centrally located across the width of the chassis. The semiconductor complement includes no fewer than 95 bipolar transistors, 66 diodes (including LED's), 2 IC's, 8 V-FET's and 4 small-signal FET's. Space limitation prevents a detailed analysis of the circuit itself, but a brief summary of the circuit elements used may prove to be of interest to readers. The circuit configuration consists of a first-stage differential FET cascode-bootstrap circuit, a pre-driver stage with current-mirror differential push-pull amplification, a driver stage featuring full complementary-symmetrical push-pull, and an output stage using the aforementioned V-FET's in a complementary configuration with parallel push-pull direct-coupled outputs to form a true DC amplifier.

Carefully matched low-noise FET's in the first stage are thermally coupled and form a differential amplifier that insures against long-term drift in the center potential that is directly connected to the speakers. The high-gain FET's used, along with temperature compensated constant-current source bias, provide a common-mode-rejection-ratio that is so high that the center-potential drift is maintained within 10 mV. The owner's manual provides additional detailed technical data regarding the rest of the circuits used in the B-2 and will be of immense interest to the technically minded owner of this amplifier.

### Test measurements

Major test results obtained during bench measurement are listed in Table I and may be compared with manufacturer's published

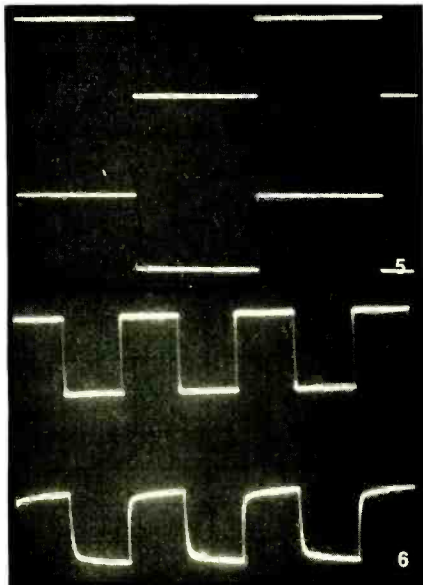

specifications shown elsewhere in this report. In order to study some of the claims made by the manufacturer beyond the normal power output, frequency response and distortion measurements, we subjected the amplifier to several other tests. With the amplifier set to the DC input mode, we applied a 10-Hz squarewave to the input (upper trace of Fig. 5) and applied the resultant output to the lower trace of our dual-trace oscilloscope. The amazingly flat squarewave reproduced by the amplifier is so similar to the input that it would be difficult to tell which is which. The squarewave frequency was then adjusted to 10 kHz, and the lower trace of Fig. 6 illustrates the wide bandwidth of the B-2 as well as its excellent transient response and

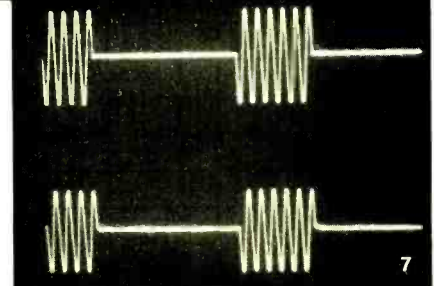

risetime. Finally, we applied a 10-kHz tone burst with approximately a one-third duty cycle to the input (upper trace of Fig. 7) and displayed the output in the lower trace of that

*continued on page 78*

TABLE I

### RADIO-ELECTRONICS PRODUCT TEST REPORT

Manufacturer: Yamaha

Model: B-2 Power Amplifier

#### AMPLIFIER PERFORMANCE MEASUREMENTS

	R-E Measurement	R-E Evaluation
<b>POWER OUTPUT CAPABILITY</b>		
RMS power/channel, 8-ohms, 1 kHz (watts)	112.5	Excellent
RMS power/channel, 8-ohms, 20 Hz (watts)	106.0	Very good
RMS power/channel, 8-ohms, 20 kHz (watts)	106.0	Excellent
RMS power/channel, 4-ohms, 1 kHz (watts)	146.0	Excellent
RMS power/channel, 4-ohms, 20 Hz (watts)	144.0	Excellent
RMS power/channel, 4-ohms, 20 kHz (watts)	142.0	Excellent
Frequency limits for rated output (Hz-kHz)	10-55	Excellent
<b>DISTORTION MEASUREMENTS</b>		
Harmonic distortion at rated output, 1 kHz (%)	0.0035	Superb
Intermodulation distortion, rated output (%)	0.058	Very good
Harmonic distortion at 1 watt output, 1 kHz (%)	0.008	Superb
Intermodulation distortion at 1 watt output (%)	0.008	Superb
<b>DAMPING FACTOR, AT 8 OHMS</b>		
	75	Excellent
<b>INPUT SENSITIVITY (For rated output, V)</b>		
	0.75	
<b>FREQUENCY RESPONSE (Hz-kHz, ±1 dB)</b>		
	DC-90 kHz	Superb
<b>HUM/NOISE REFERRED TO FULL OUTPUT (dB) (unweighted)</b>		
	108 dB	Superb
<b>OVERALL AMPLIFIER PERFORMANCE RATING</b>		Excellent

TABLE II

### RADIO-ELECTRONICS PRODUCT TEST REPORT

Manufacturer: Yamaha

Model: B-2 Power Amplifier

#### OVERALL PRODUCT ANALYSIS

Retail price	\$850.00
Price category	High
Price/performance ratio	Excellent
Styling and appearance	Very good
Sound quality	Excellent
Mechanical performance	Very good

Comments: There are those who would argue that laboratory testing of an amplifier does not necessarily disclose how that amplifier will sound and how it will compare with other amplifiers whose measurements equal, surpass or fall short of those of an amplifier being tested. We must admit that we, too, have often encountered such seeming disparities between measured and listened-to results. Such was not the case with the Yamaha B-2. It measured exceptionally well—and it sounded even better. What issue we will take with some of the statements made with regard to this product (and Yamaha's higher powered B-1) have to do with the claim that it "sounds" like a tube-type amplifier. The V-FET certainly behaves differently from a bipolar transistor, but that does not necessarily mean that it duplicates the performance of a triode. Those who insist that tube-sound offers a degree of "warmth" not found in any transistor equipment will probably not alter their opinion even after hearing the B-2. The manner in which it goes into "clipping" is not all that different from clipping observed with amplifiers using conventional bipolar transistors. Once an amplifier clips in this manner, the harmonic distortion products will be pretty much the same regardless of whether bipolar or V-FET's are used. What has been reduced to almost the vanishing point is any evidence of "notch distortion", so that listening at low and medium power levels is thoroughly transparent. Transient response, evaluated with a variety of difficult recorded material, was outstanding, but we have heard other amplifiers (which use conventional bipolar devices) that do just as well once they have been designed for excellent risetime and wide bandwidth. Certainly, the audio purist seeking a high-powered basic amplifier will want to include this new amplifier from Yamaha amongst the units auditioned before reaching any conclusions regarding the place of the power V-FET in the world of audio.





### 1) Tennis

With the tennis game the picture on the television screen would be similar to Figure 2 with one 'bat' per side, a top and bottom boundary and a center net, the individual scores are counted and displayed automatically in the position shown. The detail of the game will depend upon the selection of the options. Considering the situation where small bats are used and all angles, after the reset has been applied, the scores will be 0, 0 and the ball will serve arbitrarily to one side at one of the angles. If the ball hits the top or bottom boundary it will assume the angle of reflection and continue in play. The player being served must control his bat to intersect the path of the ball. When a 'hit' is detected by the logic, the section of the bat which made the hit is used to determine the new angle of the ball.

To expand on this, all 'bats' or 'players' are divided logically into four adjacent sections of equal length. When using the four angle option it is the quarter of bat which actually hits which defines the new direction for the ball.

The direction does not depend upon the previous angle of incidence. With the two angle option the top and bottom pairs of the bats are summed together and only the two shallower angles are used to program the new direction for the ball.

The ball will then traverse towards the other player, reflecting from the top or bottom as necessary until the other player makes their 'hit'. This action is repeated until one player misses the ball. The circuitry then detects a 'score' and automatically increments the correct score counter and updates the score display. The ball will then serve automatically from the center line towards the side which had just missed. This sequence is repeated until a score of 15 is reached by one side, whereupon the game is stopped. The ball will still bounce around but no further 'hits' or 'scores' can be made. While the game is in progress, three audio tones are output by the circuit to indicate top and bottom reflections, bat hits and scores.

### 2) Hockey/Soccer

The 'hockey' type game is shown in Figure 3, and with this game each participant has a 'goalkeeper' and a 'forward'. The layout is such that the 'goalkeeper' is in his normal position and the 'forward' is positioned in the opponent's half of the playing area.

When the game starts, the ball will appear travelling from one goal line towards the other side. If the opponent's forward can intercept the ball, (Figure 3a), he can 'shoot' it back towards the goal. If the ball is missed it will travel to the other half of the playing area and the first team's forward will have the opportunity of intercepting the ball and redirecting it forward at a new angle according to the 'player' section which is used, (Figure 3b). If the ball is 'saved' by the 'goalkeeper' or it reflects back from the end boundary, the same forward will have the opportunity to intercept the outcoming ball and divert it back towards the 'goal'.

A 'score' is made in the 'hockey' game by 'shooting' the ball through the defined goal area. The scoring and game control is done automatically as for the tennis game. The same audio signals are used to add atmosphere to the game.

### 3) Squash

This game is illustrated in Fig 4. There are two players who alternately hit the ball into the court. The right hand player is the one that hits first, it is then the left hand player's turn. Each player is enabled alternately to insure that the proper sequence of play is followed.

### 4) Pelota/Practice

This game is similar to squash except that there is only one player

### 5) Rifle Shooting

This game is illustrated in Fig 5. It has a large target which bounces randomly about the screen, a photocell in the rifle is aimed at the target. When the trigger is pulled the shot counter is incremented, if the rifle is on target the hit counter is incremented, a hit noise is generated and the target is blanked for a while. After 15 shots the score appears but the game can still continue.

### 6) Rifle Game No. 2

In this game the ball traverses the screen from left to right under control of the manual serve button. Otherwise the game is as above.

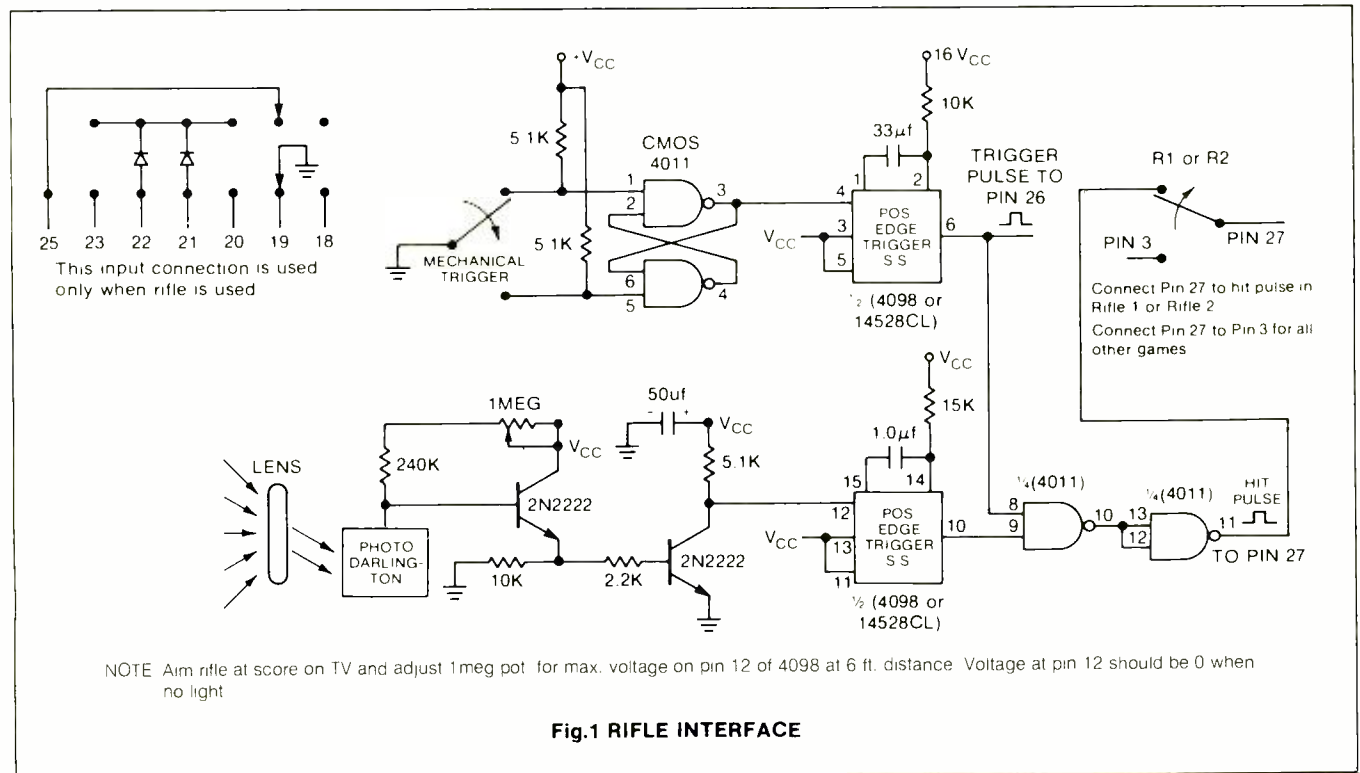

Fig.1 RIFLE INTERFACE



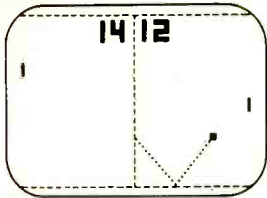

Fig.2 TENNIS GAME

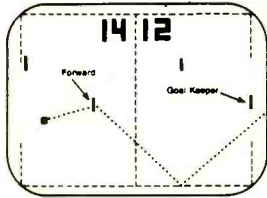

Fig.3 HOCKEY GAME

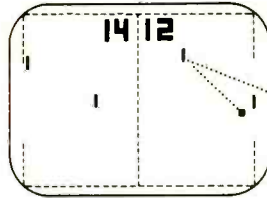

Fig.3a RETURN OF 'GOAL SAVE' Fig.3b 'SHOOTING' FORWARD

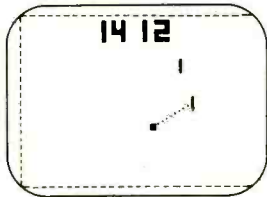
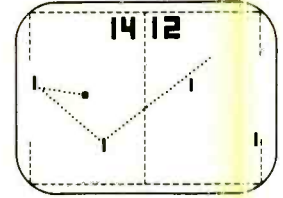

Fig.4 SQUASH

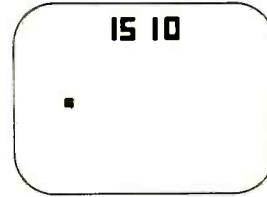
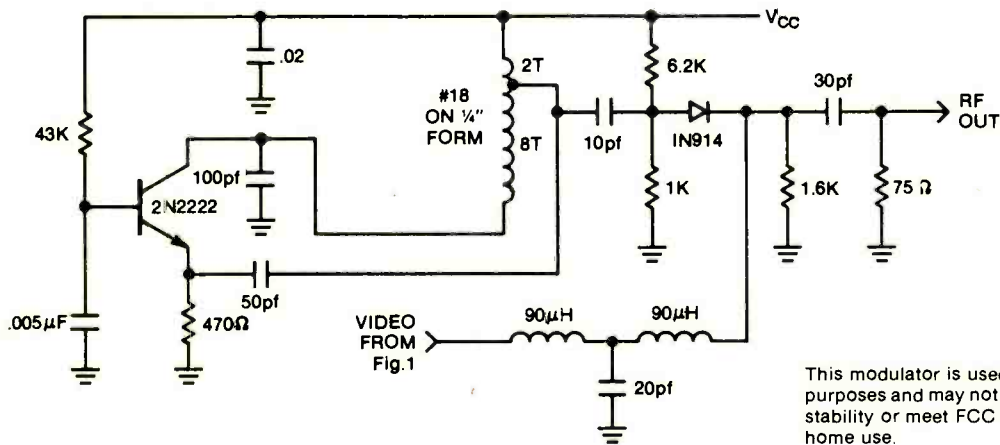

Fig.5 RIFLE SHOOT



This modulator is used in the lab for test purposes and may not possess the long term stability or meet FCC requirements for home use.

Fig.6 VHF MODULATOR

## PACKAGE OUTLINES

### 28 LEAD DUAL IN LINE

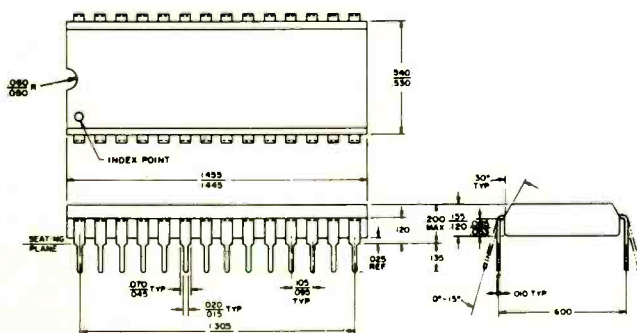

PLASTIC

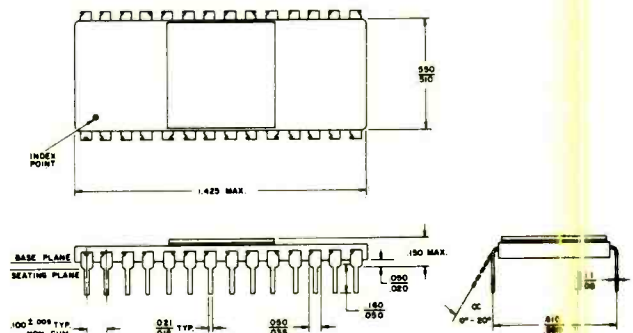

CERAMIC

## PIN FUNCTIONS

### Left Bat Input

### Right Bat Input

An R-C network connected to each of these inputs controls the vertical position of the bats. Use a 10K resistor in series with each pot.

### Reset

This input is connected momentarily to  $V_{SS}$  (Logic '0') to reset the score counter and start a game.

### Bat Size

This input is left open circuit (Logic '1') to select large bats and connected to  $V_{SS}$  (Logic '0') to select small bats. For a 19" T.V. screen, large bats are 1.9" and small bats are 0.95" high.

### Ball Angles

This input is left open circuit (Logic '1') to select two rebound angles and connected to  $V_{SS}$  (Logic '0') to select four rebound angles. When two angles are selected they are  $\pm 20^\circ$ , when four are selected they are  $\pm 20^\circ$  and  $\pm 40^\circ$ .

### Ball Speed

When this input is left open-circuit, low speed is selected (1.3 seconds for ball to traverse the screen). When connected to  $V_{SS}$  (Logic '0'), the high speed option is selected (0.65 seconds for ball to traverse the screen).

### Tennis, Hockey/Soccer, Squash, Pelota/Practice,

### Rifle Game 1 and Rifle Game 2

These inputs are normally left open circuit (Logic '1') and are connected to  $V_{SS}$  (Logic '0') to select the desired game.

Note: The "Shot" and "Hit" inputs have on-chip pull-down resistors to  $V_{SS}$ . All other inputs (except the "Bat" inputs) have on-chip pull-up resistors to  $V_{CC}$ .

### Manual Serve

This input is connected to  $V_{SS}$  (Logic '0') for automatic serving. When left open circuit (Logic '1') the game stops after each score. The serve is indicated by momentarily connecting the input to  $V_{SS}$ .

### Shot Input

This input is driven by a positive pulse output of a monostable to indicate a "shot".

### Hit Input

This input is driven by a positive pulse output of a monostable which is triggered by the shot input if the target is on the sights of the rifle.

### Sound Output

The hit (32ms pulse/976Hz tone), boundary reflection (32ms pulse/488Hz tone) and score (32ms pulse/1.95Hz tone) sounds are output on this pin.

### Sync Output

The T.V. vertical and horizontal sync signals are output on this pin.

### Ball Output

The ball video signal is output on this pin.

### Score and Field Output

The score and field video signals are output on this pin.

### Left Player Output/Right Player Output

The video signals for the left and right players are output on separate pins.

## ELECTRICAL CHARACTERISTICS

### Maximum Ratings\*

Voltage on any pin with respect to  $V_{SS}$  pin ..... -0.3 to +12V  
Storage Temperature Range ..... -20°C to +70°C  
Ambient Operating Temperature Range ..... 0°C to +40°C

\*Exceeding these ratings could cause permanent damage. Functional operation of these devices at these conditions is not implied —operating ranges are specified below.

### Standard Conditions (unless otherwise noted)

$V_{CC}$  = +6 to +7V  
 $V_{SS}$  = 0V

Operating Temperature ( $T_A$ ) = 0°C to +40°C  
F Clock = 2.01 MHz  $\pm 1\%$

Characteristics at 25°C and $V_{CC}$ = +6 Volts	Min	Typ	Max	Units	Conditions
<b>Clock Input</b>					Maximum clock source impedance of 1K to $V_{CC}$ or $V_{SS}$ .
Frequency	1.99	2.01	2.03	MHz	
Logic '0'	0	—	0.5	Volts	
Logic '1'	$V_{CC}-2$	—	$V_{CC}$	Volts	
Pulse Width —Pos.	—	200	—	ns	
Pulse Width — Neg.	—	300	—	ns	
Capacitance	—	10	—	pF	$V_{IN} = 0V, F = 1MHz$
Leakage	—	100	—	$\mu A$	$V_{IN} = +9.5V$
<b>Control Inputs</b>					Max. contact resistance of 1K to $V_{SS}$
Logic '0'	0	—	0.5	Volts	
Logic '1'	$V_{CC}-2$	—	$V_{CC}$	Volts	
Input Impedance	—	1.0	—	M Ohms	Inputs have 100K $\Omega$ pull up to $V_{CC}$
Rifle Input	—	1.0	—	M Ohms	Pull up to $V_{CC}$ Pull down to $V_{SS}$
<b>Outputs</b>					
Sync. Logic '0'	—	—	1.0	Volt	1 out = 0.5mA
Logic '1'	$V_{CC}-2$	—	—	Volts	1 out = 0.1mA
Ball. Logic '0'	—	—	1.0	Volt	1 out = 0.5mA
Logic '1'	$V_{CC}-2$	—	—	Volts	1 out = 0.1mA
<b>Sound</b>					
Logic '0'	—	—	1.0	Volts	1 out = 0.5mA
Logic '1'	$V_{CC}-2$	—	—	Volts	1 out = 50 $\mu A$
<b>Power Supply Current</b>	—	50	—	mA	



## COLOR OPTION

This option (the circuit is shown in the diagram immediately below) allows for the display of the various games in full color with different colors defining the playing area, team players, ball, boundaries, net and score.

The color application diagram is broken up into six sections, a main clock generator, a color burst locator, a phase angle generator, a phase angle multiplexer, a luminance multiplexer, and a summing network.

The main clock generator produces the 3.579 MHz clock for all the color clocks used and a 2.045 MHz clock for the chip clock. It includes 3 CMOS packages and a 3.579 MHz crystal.

The color burst locator produces the time slot after the sync pulse, being initiated from

the AY-3-8500, for a period of 11 cycles of the color frequency, approximately 3.1  $\mu$ s.

The phase angle generator produces the phase angles for all the colors used. It consists of a single CMOS package of inverters. These inverters produce phase angles, ap-

proximately 135° away from their inputs.

The phase angle multiplexer feeds the correct angle for each output from the game circuit into the summing network. This section consists of a single MOS multiplexer package.

The luminance level multiplexer produces the proper DC level for any given color so that the color is of the correct intensity. Also included is the logic necessary for generating the background timing and color. This consists of a MOS multiplexer package and two CMOS packages.

The summing network combines all the DC and AC signals without distorting their levels into a single output for RF modulation at TV receiver frequency. This section consists of 3 n-channel FET's and assorted resistors and capacitors.

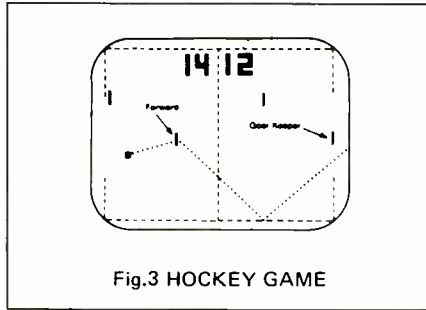
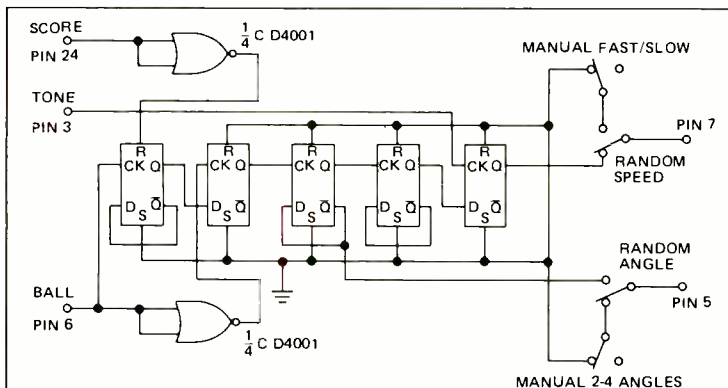
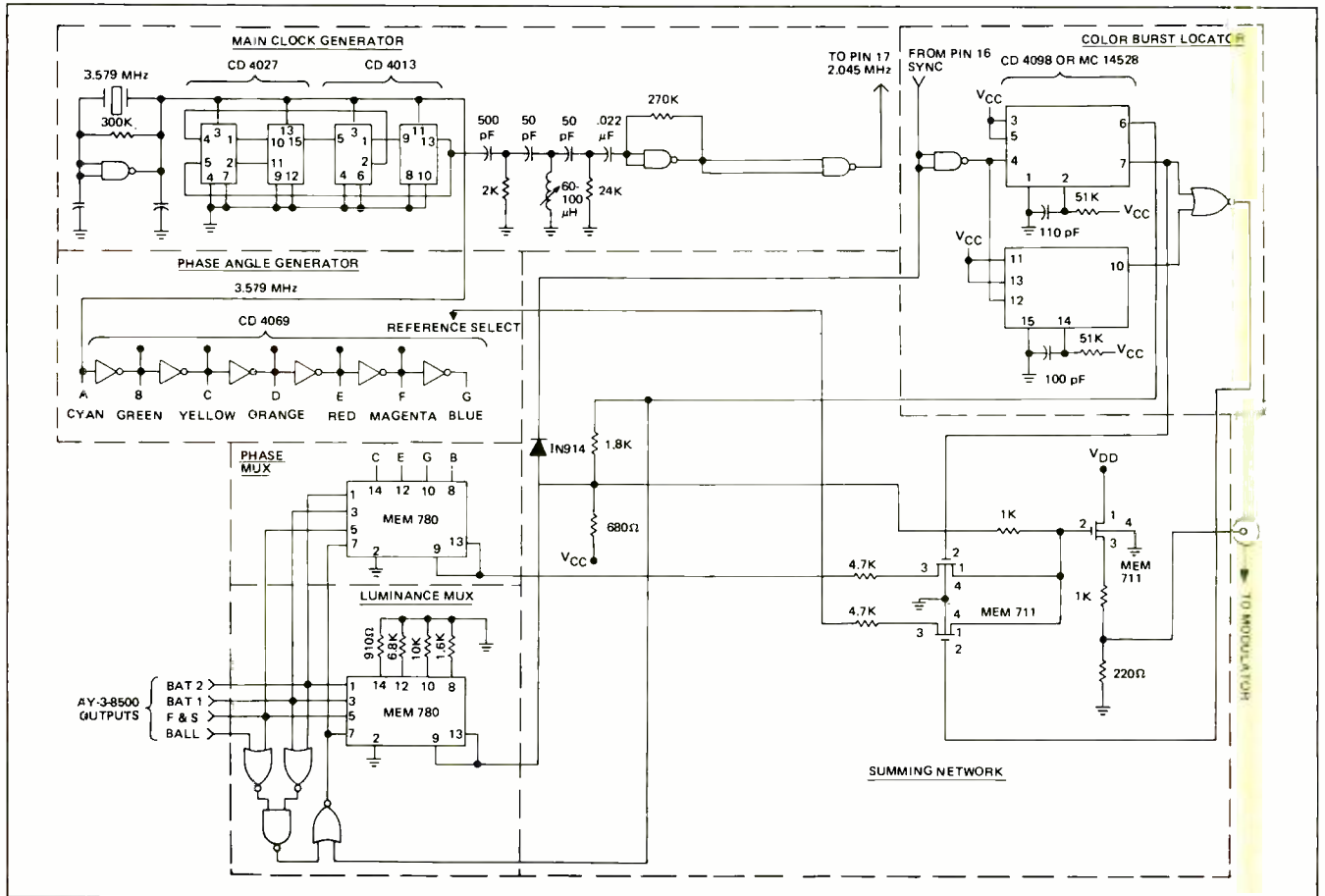
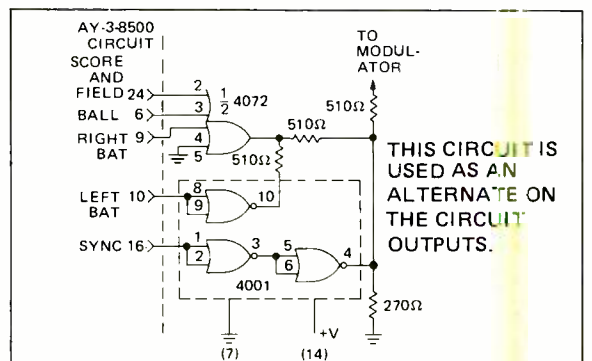

Fig.3 HOCKEY GAME



To enhance the excitement and challenge of the TV games, this option provides random variations of the ball speed and random changes in the ball rebound angle as the games are being played.



This option provides an added factor for player team recognition. The field or court is produced as a gray background with the bats in black and white. This option is particularly helpful for the squash game where the players are positioned close together.

# Timeshare— Turn your Minicomputer Into a Maxi!

Your TV typewriter or a similar keyboard/display type of terminal can be your access to a full-scale computer system. All you need is a modem and proper authorization to share computer time with many others

PATRICK GODDING

AN IDEAL COMPUTER OPERATION WOULD BE efficient for both the user and the computer system. A *single-user* system, where one terminal has complete control of the computer, allows interaction between user and computer. However, only a very small part of the computer's capabilities are used. *Batch* systems offer efficient computer use, but there is no interaction. A program must be loaded, executed, and printed before an error can be detected. After the program is corrected, the procedure must be repeated. This is inefficient from a user standpoint.

The disadvantages of *single-user* and *batch* modes of computer operation are greatly reduced in a *timeshare* system. Timeshare (or multi-user) systems allow interaction between a number of user terminals and a single high-speed computer (see Fig. 1).

## A timeshare system

The minicomputer has made it possible to build a timeshare system that can be afforded by persons not in the computer field. Price reductions in terminals and the development of less complicated programming languages have also helped bring this situation about.

The system described in this article is typical of the trend in timeshare systems: no longer the huge centralized systems, but rather many small localized ones.

## The minicomputer

Minicomputers are available in many different levels of sophistication, but all have the same standard subsystems. A CPU (Central Processor Unit) controls all internal operations and synchronizes the input/output operations. An ALU

(Arithmetic-Logic Unit) processes mathematical operations. A *control memory* contains all the hardware instructions for use by the CPU and a *data storage memory* or *core memory* contains system software instructions and data storage. Peripheral devices such as line printers, card readers, magnetic tape drives and disk drives can all be supported by minicomputers, and the more sophisticated ones can support timeshare and batch operating systems simultaneously.

## The multiplexor (MUX)

The MUX is a hardware device that interfaces all the user terminals to the computer. It operates much like a rotary switch—connecting each terminal line to the computer for a small amount of time, then going on to the next line.

The terminals and computer communicate via a binary code called ASCII (American Standard Code for Informa-

tion Interchange). Each character on the terminal keyboard is represented by an 8-bit ASCII number. The MUX receives and transmits these codes one bit at a time, so that each terminal user appears to have unique control over the computer. The delay that a user experiences is minimal or zero since the MUX and the computer operate at such high speeds.

## The disc

When a timeshare system has no provision for mass storage, the computer's core memory must be divided into a number of sections equal to the number of users. This can greatly limit the size of a user program.

With the addition of a *disc unit*, a user program can be as large as the total amount of core memory. This is done by a software system program that swaps user programs between the disc and core memory. No swapping occurs if all the programs fit in core.

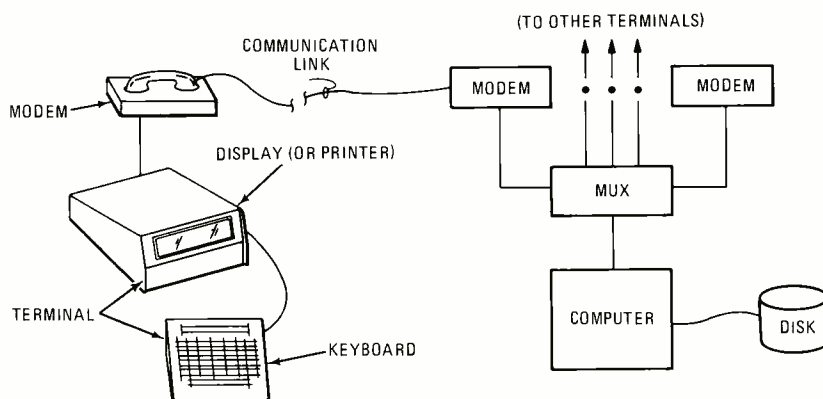

FIG. 1—TIME-SHARING TERMINAL and its connection by telephone "communications link" to a central computer. Because the computer "thinks" in terms of microseconds and the user in terms of seconds, many users can share the same computer without any observable interference or delay. The "printer" in many of these terminals is the same unit as the keyboard.



There are many types of disc units, but the concept of all is the same. The disc drive can be likened to a record player and the disc to a record, except that the drive records as well as plays. The drive also must be able to locate information anywhere on the disc, instead of simply "playing" the disc from start to finish as with a record player. Swapping programs to and from the disc does not create an unreasonable delay since many disc drives can transfer data at a rate greater than 700,000 bits-per-second.

When a disc unit is incorporated into a timeshare system, a part of the disc storage area can be allocated to the user for program storage. This provides an area both for a user library of programs that no other users have access to and also for a common library filled with programs that can be accessed and run by any user. This is an important feature because it alleviates the need to enter a program more than one time—it can be left on the disc between uses. Computer connect time (the amount of time that a user is signed-on to the system) is greatly reduced.

### The terminal

The interface between the user and the computer (or MUX) is a computer terminal. The terminal has a keyboard for sending data and some type of display or printing device for receiving data. Many terminals have their own internal memory for storing data. This can allow entering a complete program before connecting to the computer—a good feature if the user is paying for connect time. Some terminals also have external connections for cassette tape

recorders, printing units, and even disc drives (usually a discette-type drive, smaller than the discs discussed earlier).

The smaller size and reduced cost of terminals makes it possible for a user to have a terminal in an office or even in the home. When the terminal is not physically close enough to the computer for direct connection, the telephone system provides an economical communications link.

A common method of data transmission via the telephone is FSK (Frequency-Shift Keying). This type of modulation converts the serial ASCII information into two frequencies that can be transmitted readily over ordinary telephone lines. One frequency represents a logical-high level (called a "mark"), and the other a logical-low level (called a "space"). (See Fig. 2, top) The device that converts the transmitted ASCII information into FSK and the received FSK into ASCII is the MODEM (MODulator/DEModulator). A MODEM is required for each terminal line at the computer and at each terminal. A few terminals have built-in MODEM's—a good feature since an external MODEM means added expense.

### The language—Extended BASIC

Even with the low cost of a timeshare system, many people have not considered using one because of the time involved in learning to "talk" to a computer: learning the language.

Computer languages that are very similar to English now exist. The most common, perhaps, is called BASIC. It was first created for scientists and math-

ematicians who were not computer-oriented, but needed the use of a computer in their work. Now with Extended BASIC, the language has been further developed to include both powerful format statements for control of output (printed business forms, payroll checks, etc.) and file input/output capabilities for storing large amounts of data, as needed with inventories, purchase orders and the like, as well as for purely scientific purposes.

The language provides two modes of use: the immediate mode for instant calculations or program debugging and the program mode in which a user writes a group of statements to solve a specific or unique problem. The only difference between the two modes is that in the program mode, a number between 1 and 9999 must precede each statement. Examples of both types follow:

### Immediate mode

```
PRINT 3/4 )
```

This statement tells the computer to calculate the value of 3 divided by 4 and send the result to your terminal. A curved arrow at the end of the statement represents pushing the RETURN key on the terminal keyboard. The RETURN key tells the computer to begin execution.

```
PRINT SQR ((4.2 ↑ 3) + (5.3 ↑ 3) )
```

This statement says: Find the 3rd power of 4.2 and 5.3, add these results together and take the square root, then send the answer to the terminal.

### Program mode

If we wanted the above problem solved for any two numbers, we would write a short program:

```
10 INPUT A, B )
20 LET C=SQR ((A ↑ 3) + (B ↑ 3) )
30 PRINT C )
40 GOTO 10 )
RUN )
```

In this program, we have substituted variables (A and B) for the values 4.2 and 5.3.

After this program is entered into the terminal, the word RUN is entered, the RETURN key is depressed and execution begins.

When line number 10 is executed, the computer sends the terminal a question mark (?) that tells the user to enter his values. After the user enters the first value, a comma (,) the second value and depresses the RETURN key, execution continues. Line 10 has now assigned the first value that was entered to the vari-

*continued on page 25*

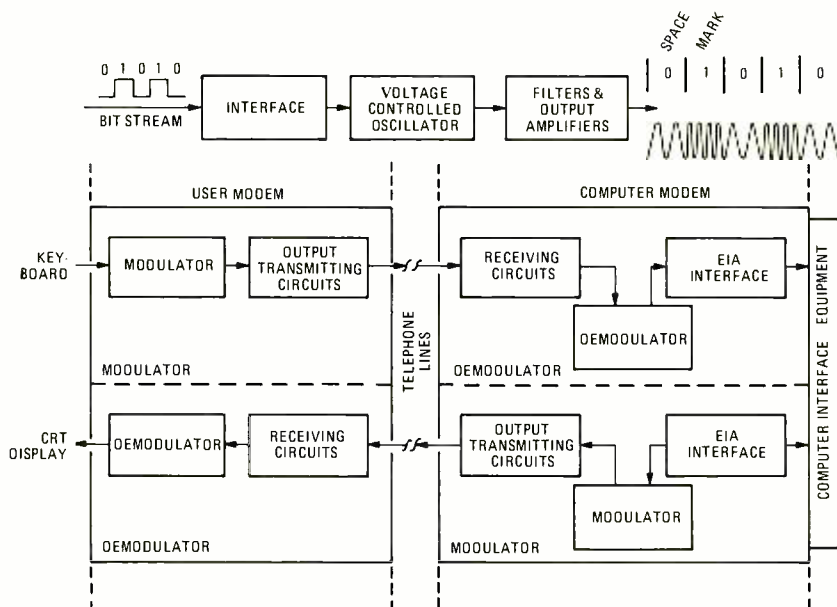
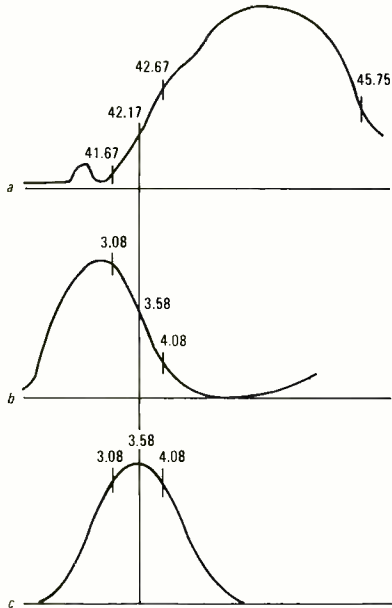

FIG. 2—HOW THE SIGNALS ARE TRANSMITTED AND RECEIVED. The marks and spaces ("bit stream" at top of diagram) are transmitted as two frequencies over the telephone lines. At the computer end, they are demodulated and sent to the computer in their original bit-and-space format. The process is reversed to return information to the terminal. Interface units prevent reaction between telephone and computer circuitry.





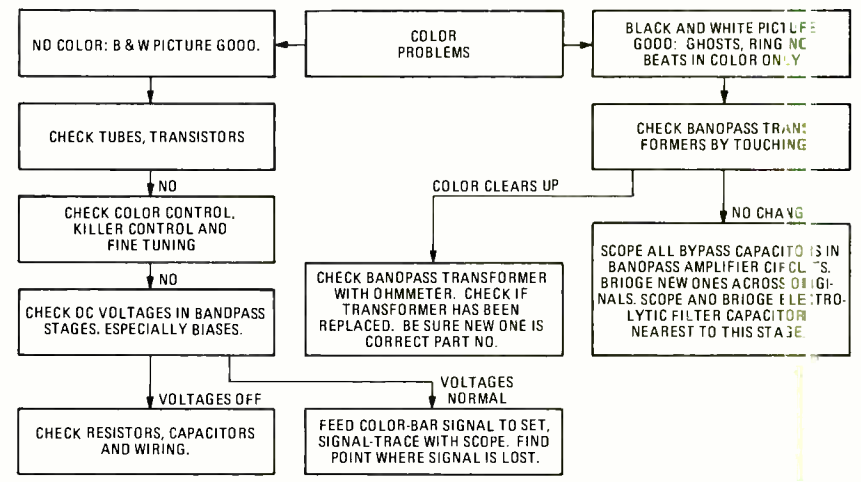

**FIG. 2—COLOR-TAKEOFF COIL RESPONSE** is shown by curve a. The frequency markers correspond to the color frequencies after the video detector. Curve b shows the video IF response and the corresponding color frequencies. The overall response is the combination of curves a and b and is the conventional haystack shown by curve c.

plier troubles is easy to identify. You'll have a good black and white picture but there will be no color at all. When you see this, be sure to make all of the *little idiot* checks! Be sure that the color-killer control is turned full up and that the color-killer control is turned full off. Last but not least, check the setting of the fine-tuning! Turn this toward the "worms", and be sure that you can see the beats in the lighter-colored areas of the picture. If so, there is color in the incoming signal. Don't overlook these checks. Every one of them has caused nuisance service calls on many many occasions.

With this symptom, we know where to look—in the bandpass amplifiers since these are the only stages which handle *all* of the color signals. Demodulators or color-difference amplifiers generally cause one-color symptoms. Too much blue, not enough red, and so on. Here we have obviously lost all colors at once.

**TROUBLESHOOTING CHART—Color problems.**



Make the simple tests first. If this is a tube type set, replace the bandpass amplifier tubes. If it is a solid-state set with plug-in transistors, do the same thing. If this doesn't help, start checking for loose wires, most especially on the color control. A great many of these have a plug-in type of connection with a coaxial cable going from chassis to the front-panel control cluster. Gremlins can make this plug come loose, break a wire to the control or even bend one of the lugs on the ground lug. (All of these have occurred and it must be gremlins; nothing else is small enough to get into the closed cabinet.)

There are two types of trouble possible. One is a fault that upsets the DC voltages, and of course, the signal as well. These are reasonably easy to locate with DC voltage checks. On tubes, check all plate, screen grid, cathode and control-grid voltages. The last should be checked without signal and with signal to catch possible faults in the color killer circuit. You should see a high negative bias on one of the bandpass amplifier grids with no signal, if the killer is working. This should drop to a much lower (negative) level when the signal is applied. Do this even though you did remember to turn the killer all the way off.

In transistor bandpass amplifiers, the emitter voltage is the most useful test. Most of them use stock common-emitter circuits

with a little resistor in the emitter. If the DC voltage on the emitter is normal, this stage is almost certain to be working. If it is zero, this transistor is open or biased to cutoff. If it's far higher than normal, the transistor could be shorted.

The second type of fault is one that breaks the signal-path but has no effect on the DC voltages. For example, an open conductor in the coaxial cable from chassis to the color control, an open coupling capacitor, a plain old open conductor on the pc board, etc. There is an extremely easy way to catch these. Just feed a color-bar signal into the set and check the waveform and its amplitude at the output of the video detector. Even on a narrow-band scope you'll see a comb pattern; these are the color-bars. Now, trace this signal through the circuit and it won't take long to find out where the signal disappears!

To check gain, compare the signal amplitude to those shown on the schematic. For example, in the circuit of Fig. 1, the input of the 1st bandpass amplifier stage is 2.0 volts P-P. The signal at the color control (input to demods, here) is 30.0 volts P-P. This procedure works even in modular or hybrid sets. In the hybrid of Fig. 3, we have a tube bandpass amplifier feeding an IC 2nd bandpass amplifier. All of the same tests apply! Signal levels differ, of course. The 1st bandpass amplifier grid is only 0.4 volt P-P. Its

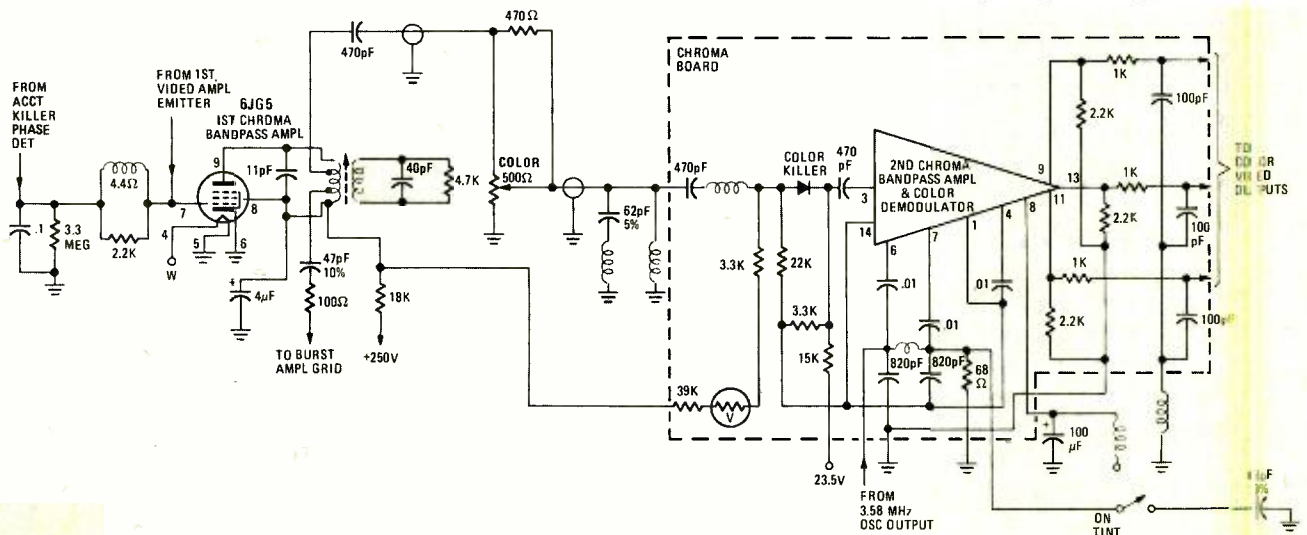

**FIG. 3—HYBRID CIRCUIT** showing a tube bandpass amplifier feeding a second bandpass amplifier in the IC.

**CIE has  
a terrific idea  
for a few people  
who know what  
they want.**

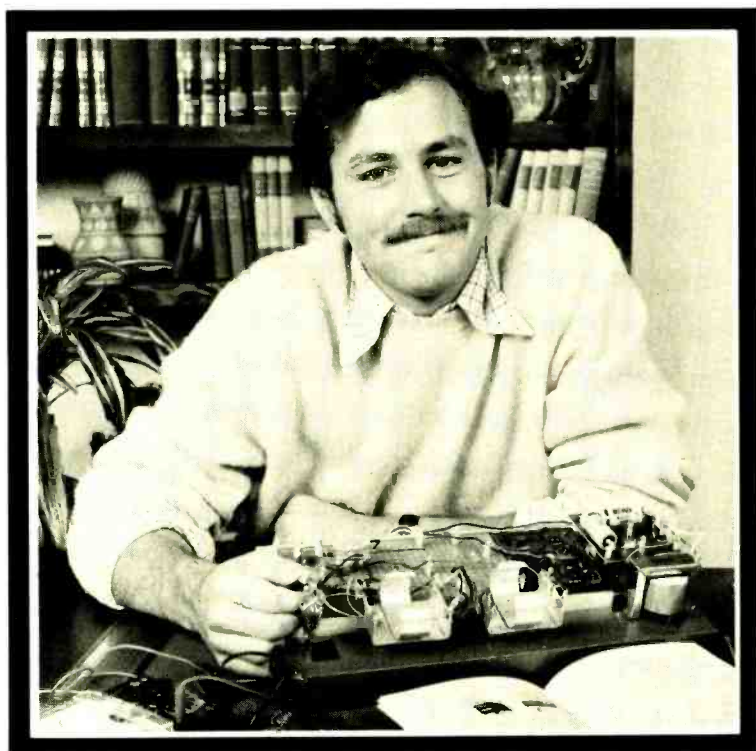



# If you want success in electronics . . . if you want the skills people are glad to pay for . . . find out about CIE training. It's a terrific idea that can get you on your way to success in electronics troubleshooting.

Let's face it, learning valuable new skills isn't something you just breeze through. Especially in a modern technological field like electronics troubleshooting. You've got to really *want* success if you're going to build your skills properly.

But, oh boy, the rewards when you do! In today's world, the ones who really *know* electronics troubleshooting find that people . . . even industries . . . look for their help.

What about you? How much do you want the thrill of success . . . of being in demand? Enough to roll up your sleeves and work for it?

## Why it pays to build troubleshooting skills .

Suppose the automated production controls on an assembly line break down. Imagine how much money the manufacturer can lose when help doesn't come *fast!* And it takes a skilled electronics troubleshooter to move in . . . locate the problem . . . solve it . . . and get the lines moving again.

Or take a TV station. Breakdowns are costly in broadcasting where time is money. Viewers won't sit forever waiting for sound or the picture to come back. Before they change channels, the station needs to get back on the air again—with the help of a skilled troubleshooter.

No question about it. Building new skills in electronics troubleshooting is an investment in your future. It's well worth the effort.

## Why you should get CIE to help you do it .

Troubleshooting starts with *ideas* . . . principles. CIE's Auto-Programmed® Lessons help you get the idea—at your own most comfortable pace. Step by step at home, you explore each principle—each theory—until you understand it thoroughly and completely. Then you start to use it.

## How CIE helps you turn ideas into reality .

If you're a beginner, you start with CIE's Experimental Electronics Laboratory. You actually perform over 200 experiments to help you grasp the basics. Plus you use a 3-in-1 Precision Multimeter to get your first taste of the testing, checking, analyzing steps you take in troubleshooting!

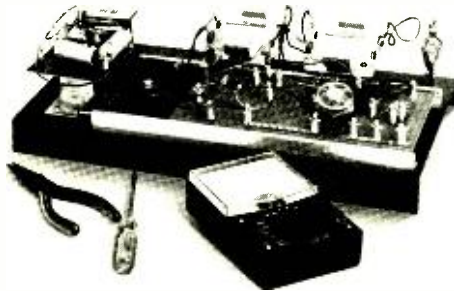

## How 3 practical steps help you build troubleshooting skills .

**You'll take your first practical step** in professional troubleshooting when you build your own 5MHz triggered-sweep, solid-state oscilloscope.

As a trained troubleshooter, you'll use your oscilloscope the way a doctor uses his X-ray machine. As a student, you learn how to "read" waveform patterns on a big, 8cm. x 10cm. screen . . . how to "lock them in" for closer study . . . how to understand and interpret what they tell you.

**Your second practical, skill-building step begins** when you get your Zenith 19-inch diagonal, solid-state color TV—featuring nine removable modules! Now's your chance to apply the new skills you learned with your oscilloscope!

With CIE's guidance, you perform actual service operations—the kind you'd handle on the job as a trained troubleshooter! Using the TV, you learn to trace signal flow . . . detect and locate malfunctions . . . restore perfect operating standards . . . just as you would with any sophisticated electronics equipment.



**Finally, step three rounds out your experience** as you work with a completely solid-state color bar generator—actually a TV signal transmitter that produces ten different display patterns on your TV screen!

You study a gated color bar rainbow . . . crosshatch lines . . . dot patterns.

You explore digital logic circuits . . . observe the action of a crystal-controlled oscillator!

This practical, "hands on" training takes concentration and effort. But it's enjoyable and rewarding. And it's a great way to prepare for a troubleshooting career!

## Why it's important to get your FCC License .

For some troubleshooting jobs, you *must* have your FCC License. For others, employers often consider it a mark in your favor. It's government-certified proof of specific knowledge and skills!

Almost 4 out of 5 CIE graduates who take the exam get their Licenses. More than half of CIE's courses can prepare you for it . . . and the broadest range of career opportunities!

## Free catalog!

Mail the card. If it's gone, cut out and mail the coupon. If you prefer to write, mention the name of this magazine. We'll send you a copy of CIE's FREE school catalog—plus a complete package of independent home study information! For your convenience, we'll try to have a representative call to help you with course selection. Mail the card or coupon . . . or write: CIE, 1776 East 17th Street, Cleveland, Ohio 44114.

## CIE Cleveland Institute of Electronics, Inc.

1776 East 17th Street, Cleveland, Ohio 44114  
Accredited Member National Home Study Council

**YES . . .** I want to succeed in electronics. Send me my FREE CIE school catalog—including details about troubleshooting courses—plus my FREE package of home study information!

NAME (please print) \_\_\_\_\_

ADDRESS \_\_\_\_\_ APT. \_\_\_\_\_

CITY \_\_\_\_\_

STATE \_\_\_\_\_ ZIP \_\_\_\_\_

AGE \_\_\_\_\_ PHONE (area code) \_\_\_\_\_

Check box for G. I. Bill information:  
 Veteran  Active Duty

IRE-96

**Mail today!**

output at the color control is 3.5 volts P-P (at the input to the module) and the color-signal input to the IC at pin 3 is 1.2 volts P-P. Its amplitude is reduced because it goes through some coupling components.

This brings up another point. In this chassis (Zenith 25CC50) the 2nd bandpass amplifier and the color demodulators are all in the same IC. The color signals are fed from the IC outputs to three color video amplifiers (same as color-difference amps). These stages drive the picture tube cathodes. The B&W video signal goes to the picture tube grids.

If you do have a normal color signal at the IC input but you can see no color signal patterns (the typical rockers or lazy-S waveforms) on the three color outputs (pins 9, 11 and 13 on the IC), the IC is bad. Watch out for one booby trap! If you can see flat-topped bar signals on all three of the outputs, the chances are that the IC is good! This could happen if the 3.58-MHz oscillator is dead. The fact that the IC will pass the signals though it isn't demodulating them could mean that the oscillator has dropped out. Be sure to check for the presence of the 3.58-MHz signal on pins 6 and 7 of the IC. It's not very large, but it's got to be there.

These waveforms can be seen if a direct probe is used. They'll be a little clearer if a low-capacitance probe is used, and better still if you use a crystal-detector probe. After all, these are RF signals. The actual waveform doesn't make a lot of difference; all you want to do is compare amplitudes and get an "Is it there or isn't it?" reading. This is "bang-bang" scope-testing at its best. (I can recommend one thing that will be of a whole lot of help. Check these waveforms on a set that is working! Try different probes and note the amplitude at various points. This will give you a set of bogie values to use when checking a set that's dead.)

## Alignment

There is one key word which must be said about alignment of bandpass amplifiers. This word is **DON'T!!** Caps, bold and two exclamation points. May I repeat this for added emphasis? **DONT!** When you find problems that have caused a complete loss of color or even those that cause odd-colors (which we'll get to in a minute), don't start twisting the cores of the bandpass transformers! This didn't cause the sudden loss of colors. You'll only add one more fault that will have to be fixed after you find the real one, and the misalignment that you will cause will make this job far more difficult. (The exception that proves this rule is the case where you know, or have a pretty good idea, that a previous "technician" has been into them with his liddle diddle stick!)

## Unusual troubles

The preceding section was covered faults that could be called "stock"; more or less common things. Now let's look at a few oddballs that are not nearly so common, but always possible. You should know about these and remember them. It can save a lot of time.

One of the best of these is ringing in the color only. By this I mean that the B&W picture does not show any sign of ghosting. Turn up the color control and you see colored ghosts or beats all over the place. These are distinctly different from the beats produced by mistuning the fine-tuning. The latter shows beats in solid-colored areas only; this shows over the entire picture.

The basic cause of this kind of trouble, of course, is oscillation. The bandpass stages instead of amplifying are in violent oscillation. So, we get beat-frequencies and beats between beats and the whole signal turns into a mess! Going one step farther back, all

oscillation is due to feedback.

Open bypass capacitors can cause this. All tuned transformers will be bypassed at the bottom end of one or both windings to place this point at signal-ground. Since these are high-frequency signals, small capacitors are used. One of the best tests for this is to scope the bottom of the windings right on the bypass capacitor. Turn the vertical gain as high as possible and look for any sign of signal. It helps to feed a known signal through the set, like the output from a color-bar pattern generator.

If you see signal, bridge a good capacitor across the one under test and see if this gets rid of the unwanted signal, and usually the problem as well. If so, replace the capacitor. (In one somewhat odd case, the original capacitor turned out to be very good! To eliminate the problem I had to add another capacitor of the same size.) By the way, don't forget the filter capacitors. These too can develop faults and allow a feedback loop to be set up through the DC power supply. This can cause some dandy problems. Scope them too.

Another possible cause for oscillation can be trouble in the bandpass transformers. In some sets with tapped windings, the tap can open. Figure 4 shows one like this. A lead on the secondary of the input transformer opened. This disconnected the shunt resistor used to damp this winding and the whole thing went into violent oscillation. There's a simple test for this; most of these use unshielded transformers. Just grab the transformers between thumb and finger; this will add enough "hand-capacitance" to cause at least a change in the oscillation. The ohmmeter will find the open winding very quickly.

Another case with the same symptoms, and the same basic cause, happens if the bandpass transformer is replaced with the wrong part. Some sets have two types of bandpass transformers. They look alike and will fit in the holes on the PC board. However, the wrong one will leave the damping resistor across one winding disconnected! So, we get exactly the same trouble, though "It can't be the transformer! I just replaced that!". When replacing these, double-check to be absolutely sure that you get the correct part number.

## Weak color

Cases where the complaint is not loss of color but weak color, can be due to misalignment although this generally causes other symptoms. It can also be due to an ACC circuit that is overdoing its job a little. The key clue here will be the control voltage. Check this carefully to be sure that it isn't too far in the direction of cutoff; negative for tubes and the NPN transistors most commonly used, positive if they are using a PNP transistor. The actual cause of the problem could be a leaky or open diode in the ACC.

## Intermittent loss of color.

If all colors are lost intermittently, look for things like a plug/socket contact on the cable from the color control to the chassis. An intermittent open in the center conductor of the coax, or an intermittent ground due to a frayed shield could also do it. Once again, stage by stage signal-tracing will soon pin down the point where the signal is being lost.

R-E

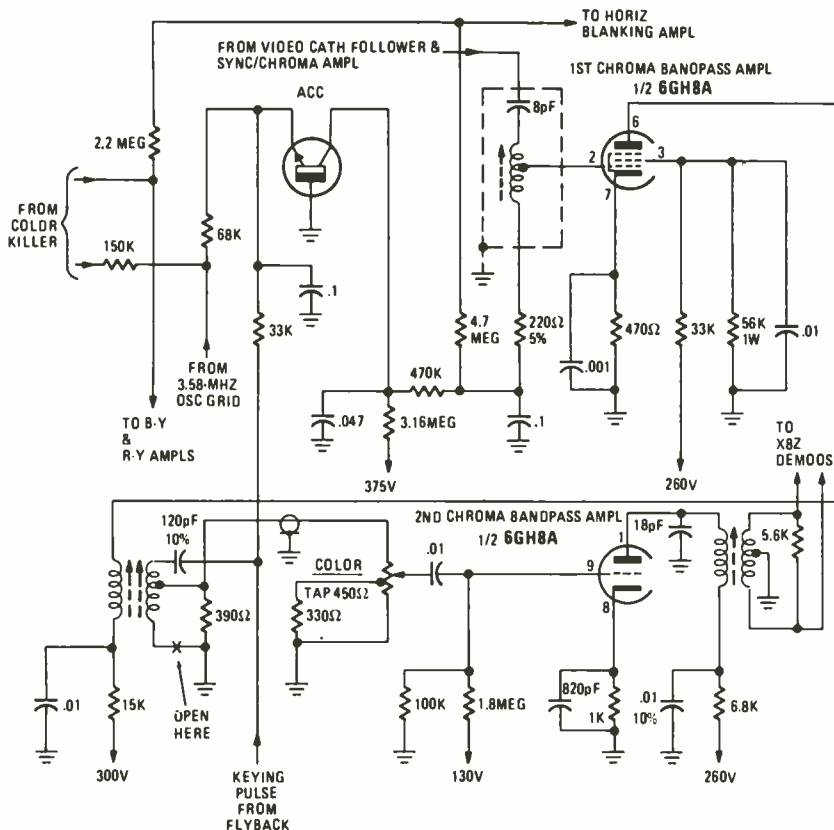

FIG. 4—COLOR RINGING can be caused by an open tap on the bandpass transformer.



# R-E's Service Clinic

## Fast Recovery Diodes

*A diode is a diode—or is it?*

**JACK DARR**  
SERVICE EDITOR

EVERYWHERE WE LOOK—DIODES! CIRCUITS are full of them nowadays. All the way from tuners to detectors, to power supplies, to switches, to you name it. A lot of these are special types, such as varactors. However, while we're pretty familiar with these by now, there is another special type that has been around for quite a while. A lot of us are not familiar with this. Present company included; I've been booby-trapped on a couple of occasions!

This is the *fast-recovery diode*. You'll find them used in damper, boost rectifier and similar applications. They're also used in the flyback DC power supplies found in many late model sets. (We talked about these in a previous column.) This circuit uses pulses from the flyback that are rectified to develop low DC voltages. (See Fig.

1.) Some are connected so that they use the long "scan" portion of the pulse; these are called *scan rectifiers* (how about that?). Others are hooked up so that they use the very sharp spike developed during flyback time; these are called flyback rectifiers, retrace rectifiers, etc. Operating frequency in both types is 15,750 Hz although there is a vast difference in the duty cycle of pulses. Scan pulses will be almost 60 microseconds long, but the flyback pulses will run around 10–15 $\mu$ S.

This kind of circuit needs a special type of diode. The common rectifier diode works on 60-Hz sinewaves and the recovery time isn't all that critical. Recovery time means the diode's ability to *turn off* when the polarity of the applied voltage reverses. In the flyback rectifier with the short duration spike,

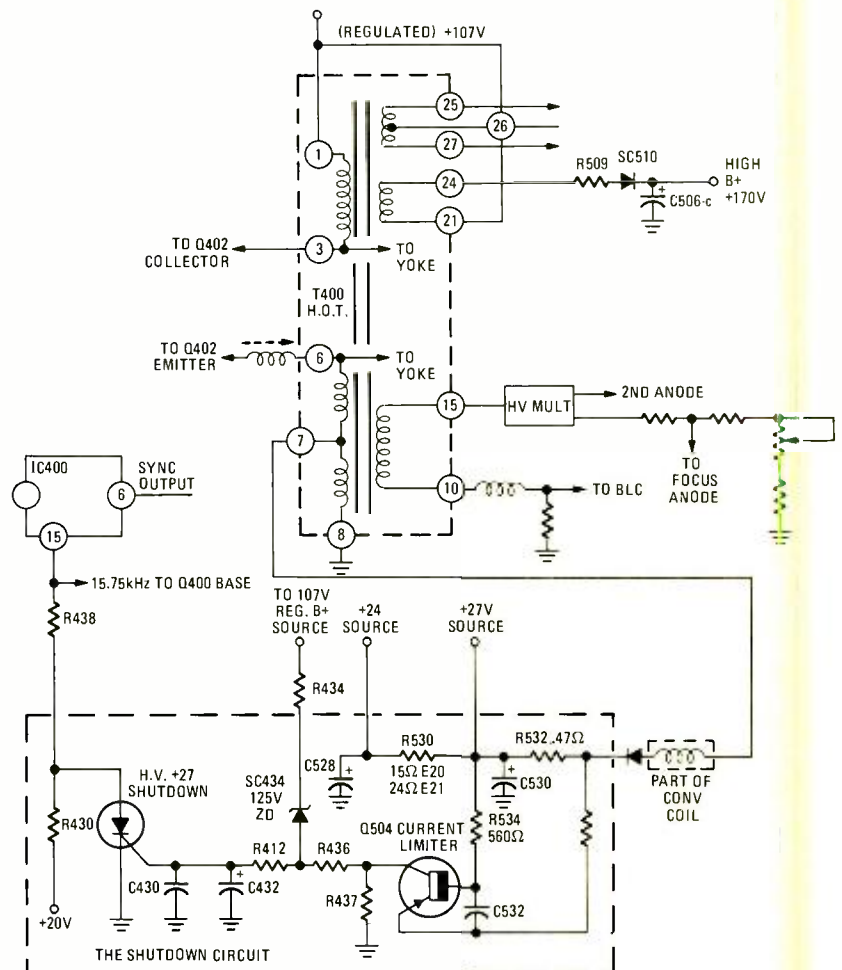

FIG. 1

the turn-off time is critical. If the wrong diode is used it can foul up the operation.

A conventional rectifier diode has a turn-off (reverse-recovery) curve looking something like Fig. 2-a. The special fast-recovery diodes, sometimes called fast-switching diodes, have a characteristic called snap-off (see Fig. 2-b). If this is too fast, it can cause problems. The rapid change of current develops harmonics that cause the diode to radiate RF interference! So, they redesigned the junctions to have a controlled recovery characteristic as shown in Fig. 2-c. This diode has a fast recovery but without

the very abrupt switch-off. (I remember reading about an abrupt diode a long time ago; it took me years to find out what the heck it was!)

Now let us look at a few typical applications for these diodes. One is in the DC power supply such as the one used in the new Sylvania E20 and E21 chassis. This power supply is shown in Fig. 1. One diode is used as the rectifier in the +170-volt supply. This is actually a boost type of circuit—regulated B+ of +107 volts is fed to the flyback; the pulses are rectified and added to this so that the total comes out as +170 volts. This voltage is developed through diode

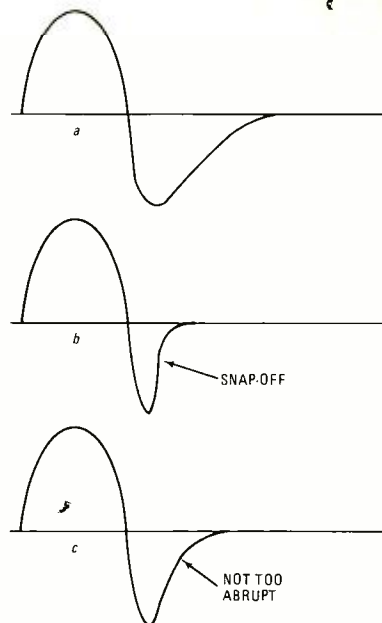

FIG. 2

SC510 that charges C506-C to this peak value.

A regulated +27-volt supply is developed from another winding on the flyback. From terminal 7 of the flyback, the voltage is rectified by SC530 and filtered by capacitor C530. The output of the +27-volt supply is monitored by the current-limiter transistor. This transistor triggers SCR430 which kills the high-voltage. The 107-volt B+ supply is also monitored through Zener diode SC434 for this same purpose. If any of these voltages go out of limits, SCR430 trips which then kills the horizontal drive signal to the horizontal output stage and turns practically everything off at once.

If a diode fails in this type of circuit, it must be replaced by an exact duplicate: never by an ordinary rectifier type regardless of the PIV (Peak Inverse Voltage) rating. In some of the typical fast-recovery types that I looked up, recovery time runs from 0.5 microsecond to 100 nanoseconds, and that is FAST! Typical units are G-E's GE-511, Sylvania's ECG-506, RCA's SK-3515, 3517 or 3175, and so on.

For a very good discussion of how these diodes work along with the mathematics, see RCA's *Solid-State Power Circuits Designer's Handbook*. This is where I got the curves of Fig. 1. I had to dig through quite a lot of books before I found anything at all about them!

There have been quite a few letters in the *Clinic* mail lately about diode failures in circuits of this type. In quite a few, the complaint was repeated diode failure although the load circuit fed from this DC supply showed no problems! One irate technician even disconnected the load circuit and ran it on an external DC power supply, whereupon it worked perfectly! This one was in a late model Sears color TV, and we have

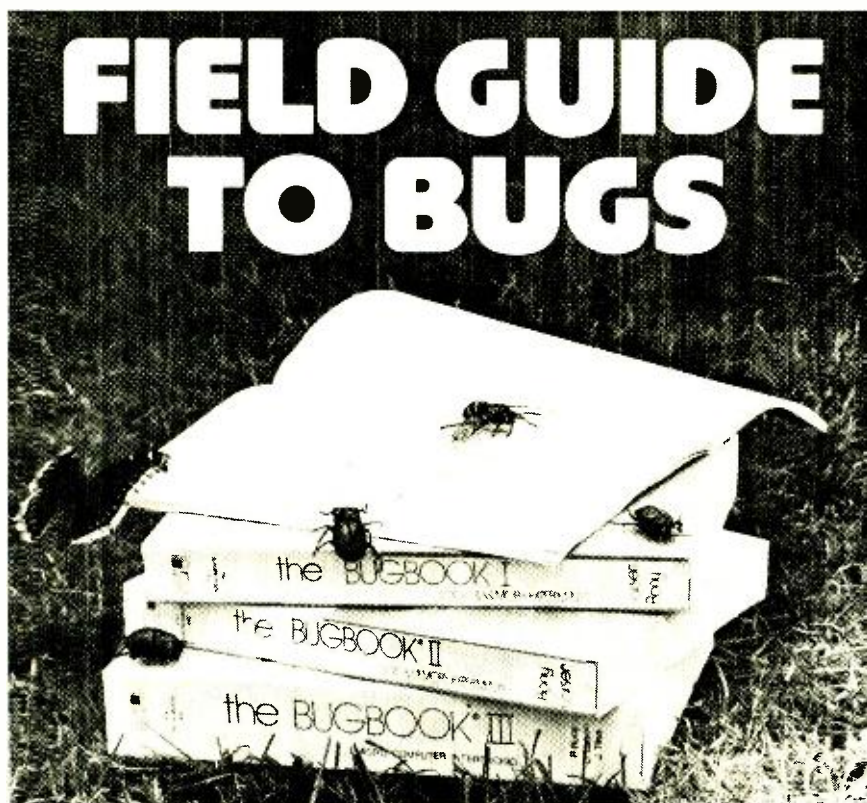

# FIELD GUIDE TO BUGS

## SPECIAL PRICE

The Bugbook library — Bugbooks I, II, IIA and III — are available together at the factory direct price of \$37.00 . . . save postage and handling . . . order today.  
Prices applicable only in the U.S. and its possessions.

In a world crawling with bugs, it's good to have the Bugbooks® by your side. Good to have just four books dedicated solely to teaching you digital electronics . . . from ground zero on up. From fundamental logic and memory experiments to interfacing with microprocessors. The Bugbooks are E&L Instruments' pioneering approach to mastering today's pulse-quick world of micro-electronics. With an approach that's simple and straightforward. Clear. Complete. Well-illustrated. And as fresh as tomorrow's circuit design. In all, some 1350 pages. They're the Bugbooks. Don't ven-

ture a step farther into the world of digital electronics without them. Because the place is crawling with bugs.

## CIRCUIT DESIGN, INC.

Division of E & L Instruments, P.O. Box 24, Shelton, Conn. 06484

Gentlemen:  
Please send me the set of Bugbooks for \$37.00 postpaid.

Name \_\_\_\_\_  
Company \_\_\_\_\_  
Address \_\_\_\_\_  
City \_\_\_\_\_ State \_\_\_\_\_ Zip \_\_\_\_\_

Enclose check or money order or valid BankAmericard or Master Charge information.



had quite a few cases involving the same model. I have been recommending replacement of this diode with a fast-recovery type. As we already stated, regardless of the peak inverse voltage rating or the current rating, a "slow diode" just won't work properly in this type of circuit. So, if you run into diode failure in sets using this kind of DC power supply, watch it! Be sure to use either an exact factory replacement part or a high-rated fast-recovery type from one of the better lines of replacement semiconductors. **R-E**

## reader questions

### POOR FOCUS

*I can't get a sharply focused raster on this CTC-25X. The high voltage is 25 kV, B+ is 405, boost normal, but I can get only 4200-4300-volts for the focus. The 4.7 megohm and 66-megohm resistors all check. The core of the focus transformer is all the way out and I still can't get focus. Any help appreciated.—G.S., Red Bank, NJ.*

You're right: you're not going to get sharp focus with 25-kV and only 4.3-kV focus voltage. It takes about 20% of the

high voltage for sharp focus, or in this case, a bit over 5 kV. Since the focus circuit and high voltage are driven by the same flyback pulse, everything else has to be OK! So, we've still got something in this focus circuit.

Since the transformer shows a normal reaction, and your cathode current isn't high, it probably is not shorted. This leaves only one likely part: that voltage-dependent resistor shunted across the focus transformer. This is a 1.0 mA at 870-volt type. Try an RCA 112876 or an Oneida GB-314. Try a new one. If it has gone down, it would load the focus transformer.

### SAFE RATING OF RECTIFIER DIODES?

*This Coronado TV6-1614A came in with both rectifier diodes open. These are 200-PIV units, in parallel. Could find no short or overload. Replaced with the same type. In two weeks it is back and they're open again! So, I put in a single 1.0A 600 PIV silicon. It's playing fine and seems to be holding up. What do you think?—W.S., Bonaparte, IA.*

In my opinion, you did the right thing! A 200-PIV rectifier diode is just running a little too close to the bone on a 125- or 130-volt AC line. I like lots of safety factor, and you also seem to. Good idea. **R-E**

## Senturion Ultimate Long Range Radar Detector

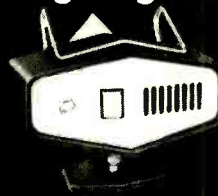

NEW!

NOW ONLY \$89.95

### SENTURION — 12 Volts Powerful

Safe professional drivers require the ultimate in advance notice of radar traffic control zones — computer designed antenna-integrated circuitry — audible and visual warning — operates off your car's electrical system. Send check, C.O.D. or charge to my credit card as indicated.

10 Day Money Back Guarantee  
**RADATRON CORP.**  
 Dept. 2424-49 P.O. Box 177  
 N. Tonawanda, N.Y. 14120

Am. Exp.  
 Carte Blanche  
 Diners Club  
 Master Charge  
 C.C.D.

Charge my credit card acct. no. Expir. Date \_\_\_\_\_

\$89.95 each plus postage & tax where applicable.

Signature \_\_\_\_\_

Name/Please Print \_\_\_\_\_

Address \_\_\_\_\_

City \_\_\_\_\_ State \_\_\_\_\_ Zip \_\_\_\_\_

**CIRCLE 2 ON FREE INFORMATION CARD**

# Build your own Digital Clock!

CAT. NO. G2-108

- Bright LED readout
- AM-PM indicator
- 110 V operation
- Step-by-step instruction booklet

It's easy with the Calectro Digital Clock Kit! The complete kit with everything necessary for fast, easy assembly, including illustrated step-by-step instructions. See the Digital Clock, TTL Power Supply, Motor Speed Control, DC Regulated Power Supply and Burglar Alarm kits at Calectro dealers everywhere!

*Calectro Kits - Ready to Assemble  
 Fun - Practical - Educational*



**GC ELECTRONICS**  
 DIVISION OF HYDROMETALS, INC.  
 ROCKFORD, ILLINOIS 61101 U.S.A.

CIRCLE 71 ON FREE INFORMATION CARD

# LEARN QUICKLY—EASILY—AT HOME

## Only I.H.S.I. offers these unique correspondence courses

**MATHEMATICS ■ ELECTRONICS ■  
ENGINEERING MATHEMATICS ■ ADVANCED MATHEMATICS ■  
ADVANCED ENGINEERING MATHEMATICS ■**

These unusual courses are the result of many years of research and teaching by the President of INDIANA HOME STUDY INSTITUTE, who has *personally* lectured in the classroom to *thousands* from all walks of life on mathematics, electrical and electronic engineering.

- You must see these lessons to appreciate them!
- NOW you can master mathematics and electronics and actually *enjoy* doing it!
- WE ARE THIS SURE:—you order your lessons on a *money-back guarantee*.
- In plain language, *if you aren't satisfied you don't pay a cent*.

There are no strings attached.

WRITE TODAY for more information and your outline of courses. You have everything to gain and nothing to lose!

LICENSED BY THE STATE BOARD OF INDEPENDENT POST-SECONDARY VOCATIONAL, TECHNICAL, TRADE AND BUSINESS SCHOOLS.

**THE INDIANA HOME STUDY INSTITUTE  
EASTERN DIVISION  
P.O. BOX 1189  
PANAMA CITY, FLA. 32401**

CIRCLE 14 ON FREE INFORMATION CARD

## R-E TESTS YAMAHA B-2 AMP

*continued from page 60*

same scope photo. The accuracy of the reproduced tone-burst speaks for itself.

Yamaha had made much of the fact that the V-FET circuitry used in both the *B-1* and *B-2* amplifiers results in the generation of fewer high-order harmonic-distortion components. While this may well be true at power output levels below rated power, our spectrum analyzer's 75-dB dynamic-range capability precluded examining harmonic distortion on a harmonic by harmonic basis. 75-dB "down" is equivalent to only 0.0178% THD, and since, at less than rated power output levels the measured THD (as a single number) was only 0.008% or thereabouts, we could not display harmonic distortion components on the analyzer. At clipping, however, when distortion begins to reach more significant percentages, we were able to analyze the individual components that make up the distortion and, as can be seen in Fig. 8, higher-order distortion components be-

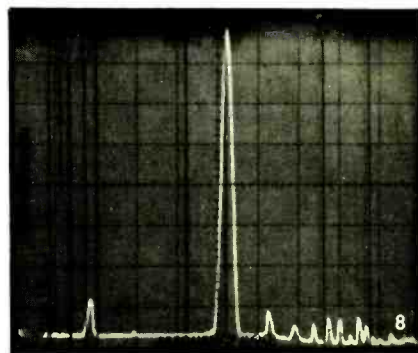

come just as significant as the usual second and third order components.

### Use and listening tests

Our overall comments concerning the sound of the *B-2* will be found together with our summary product analysis, in Table II. In using the amplifier for several days, we were particularly impressed by the action of the power meters which have an unusually rapid risetime (100 microseconds) and a slower (1 second) decay time. They therefore permit the user to really monitor close-to-true peak power of this (or any other externally connected) amplifier or of an externally used preamplifier and serve a function that we deemed more useful than that of the average-reading or conventional VU-meters found on some competitive products.

Despite the fact that the V-FET's require considerably higher quiescent (no signal) current than do conventional bipolar devices used in Class-B audio output circuits, there was little if any evidence of undue heat rise after hours of continued use of the amplifier for music listening purposes. Unless you are terribly concerned about the cost of the extra few watts consumed by this unusual amplifier, the extra current demanded by the V-FET circuitry should not pose a problem.

Obviously, an \$850.00 basic power amplifier is not everyone's idea of how much they would like to spend for 100 watts-per-channel of pure audio amplification. But, in the case of the *B-2*, pure amplification is what you get—in every sense of the word. **R-E**

## Don't Get Caught With Your MODULES DOWN

*Increase Your Profits By Utilizing  
Our Module Rebuilding Program*

*Consider these features!*

- **Original Parts.** We use ONLY original parts. Brands we rebuild include Magnavox, Admiral, GE, Montgomery Ward, Quasar, RCA, Zenith and others.
- **Quality.** Only professionally trained technicians will handle your modules. All modules are tested, temperature cycled, retested and airtested.
- **Protective Packaging.** Rebuilt modules are returned to you in polyethelene skin packaging for protection during shipping and storage.
- **Fast Service.** Quick, reliable service is our tradition.
- **One Year Warranty.** One year limited warranty on workmanship and parts.

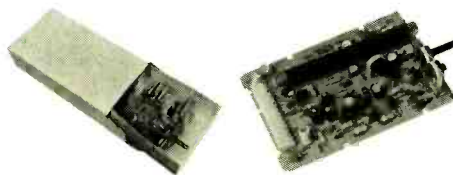

**PTS ELECTRONICS, INC.**

P.O. Box 272 Bloomington, IN 47401 812-824-9331

OR, check the white pages for the location of the PTS branch nearest you.

CIRCLE 64 ON FREE INFORMATION CARD



# FREE burglar — fire alarm catalog



over 900 systems, detectors, controls, sounders, tools, locks, supplies

## TO PROTECT HOMES, BUSINESSES, INDUSTRY

Huge selection of hard-to-find security equipment from stock. 64 fact-filled pages loaded with 100's of highest quality professional alarm products, technical notes, diagrams.

### ONE-STOP SUPERMARKET SELECTION INCLUDES:

ultrasonics, radar, infrared, undercarpet mats, magnetic contacts, smoke & heat detectors; Controls; Alarms: bells, sirens, phone dialers, lights, guard panels. Large selection of tools, relays, wire, holdup alarms, books. Fills need for industry, alarm cos., businesses, homes, institutions. Order your copy today. (Outside U.S., send \$1.00.)



mountain west alarm  
4215 n. 16th st.  
phoenix, az. 85016  
(602) 263-8831

CIRCLE 4 ON FREE INFORMATION CARD

## KOMPUTER KORNER

continued from page 25

SET switches, while the SNOOZE-ALARM DISPLAY switch is pressed, resets the alarm time to 12:00 AM.

If the alarm function is to be used, the PM output (pin 3) of the MM5385 must be used to activate an LED so that the alarm may be set for AM or PM. A current-limiting resistor (180 ohms for 10 mA) must be used in series with the LED.

Pressing the SNOOZE-ALARM DISPLAY switch also inhibits the alarm output for between 8 and 9 minutes after which the alarm is sounded and the alarm time is displayed.

When the alarm latch, S4, is closed, an output is available to drive an NPN transistor, as shown in Fig. 1. This output is available for 59 minutes unless the SNOOZE-ALARM DISPLAY switch is pressed, or unless the alarm is reset by the ALARM OFF switch. If it is desired to silence the alarm for a day or more, the ALARM OFF switch must remain closed. The alarm feature would be a valuable addition to the auto digital clock in truck installations.

to be continued



## HIGH BLOOD PRESSURE. Treat it... and live.

The National High Blood Pressure Education Program, U.S. Department of Health, Education, and Welfare.

# FREE catalog over 2000



unique tools, hand kits, precision instruments, technical supplies.

Over 24 years of service to the world's finest craftsmen and technicians.

A carefully selected and tested assortment of unique, hard-to-find tools, clever gadgets, precision instruments, bargain kits. One-stop shopping for the technician, craftsman, hobbyist, lab specialist, production supervisor. Many tools and measuring instruments available nowhere else. One of the most unusual and complete tool catalogs anywhere. Get your copy of the NC FLASHER today.



**National Camera**  
2000 West Union Ave., Dept. CB  
Englewood, Colorado 80110  
(303) 789-1893

CIRCLE 10 ON FREE INFORMATION CARD

# You've seen the rest... now try the best.

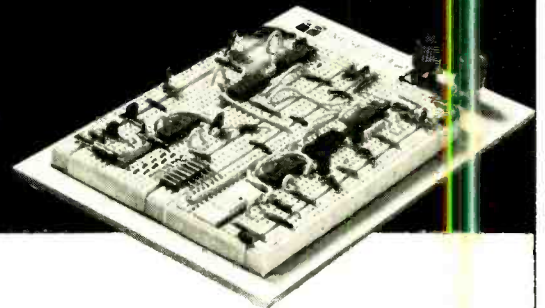

Solderless strips, backing board and binding posts. Everything you need to build and test your own circuit. Used to be you'd get a circuit idea, lay out a pc board, print it, solder everything together, trouble-shoot, change your layout, try a new board, and spend absolutely too much time breadboarding. Now A P ACE All Circuit Evaluators let you breadboard in a fraction of the time. Make your changes immediately. Keep full leads on your components. Avoid the heat damage possible with repeated soldering and de-soldering. A P made the first modern solderless breadboard, and we still make them best.

Pick an ACE for Faster and Easier solderless circuit building and testing.

Send for our complete A P catalog, The Faster and Easier Book.

Part No.	ACE Model No.	Tie Points	DIP Capacity	No. Buses.	No. Posts	Board Size (inches)	Price Each
923333	200-K (kit)	728	8 (16's)	2	2	4-9/16x5-9/16	\$18.95
923332	208 (assem.)	872	8 (16's)	8	2	4-9/16x5-9/16	28.95
923334	201-K (kit)	1032	12 (14's)	2	2	4-9/16x7	24.95
923331	212 (assem.)	1224	12 (14's)	8	2	4-9/16x7	34.95
923326	218 (assem.)	1760	18 (14's)	10	2	6-1/2x7-1/8	46.95
923325	227 (assem.)	2712	27 (14's)	28	4	8x9-1/4	59.95
923324	236 (assem.)	3648	36 (14's)	36	4	10-1/4x9-1/4	79.95

Order from your A P distributor today. Our distributor list is growing daily. For the name of the distributor nearest you call Toll-Free 800-321-9668.

## A P PRODUCTS INCORPORATED

Box 110-R Painesville, OH 44077  
(216) 354-2101 TWX: 810-425-2250



CIRCLE 11 ON FREE INFORMATION CARD  
www.americanradiohistory.com

Are you,  
of all people,  
still opening  
your garage

the  
hard  
way?

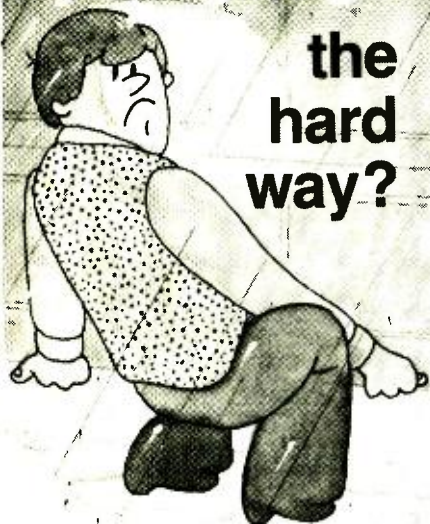

## Anybody who's into electronics

certainly should be getting the everyday convenience and family security of automatic garage door operation... especially now, with Perma Power's great Electro Lift opener...

made to fit in the trunk of your car, designed for easy handling and simple do-it-yourself installation.

Available now at a surprisingly low price from your distributor.



**P.S.** Show off your opener to your friends and neighbors. You'll probably be able to pay for yours with what you make installing openers for them.

# Perma Power

Chamberlain Manufacturing Corporation  
Perma Power Division  
5740 North Tripp Avenue, Chicago, Illinois 60646  
Telephone (312) 539-7171

CIRCLE 52 ON FREE INFORMATION CARD

# new products

More information on new products is available from the manufacturers of items identified by a Reader Service number. Use the Free Information Card following page 88.

**AUDIO INSULATORS.** The model AT-605 is one method of combatting low-frequency acoustic feedback by isolating the phono pickup from vibrations such as rumbles from deep bass notes, passing buses and subways, and floor disturbances. The four height-adjustable chrome-finished insulators, selling for under

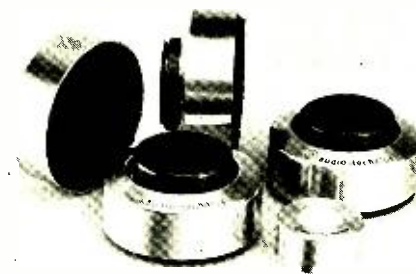

\$25.00, help absorb disturbances before they reach the turntable. The audio insulator set fits under turntable or speaker corners, assuring optimum tone-arm tracking as well as protection. The set includes a small bubble level, permitting accurate height adjustment necessary for maximum performance with today's lightweight pickup arms.—Audio-Technica, 108 N. State St., Chicago, IL 60602.

CIRCLE 72 ON FREE INFORMATION CARD

**INTRUSION ALARM, model A-18** uses existing public address, paging or background music speakers as sound pickups. Sounds of intrusion such as breaking glass, hammer blows, footsteps, etc., cause the output relay to operate while normal building sounds such as heaters or

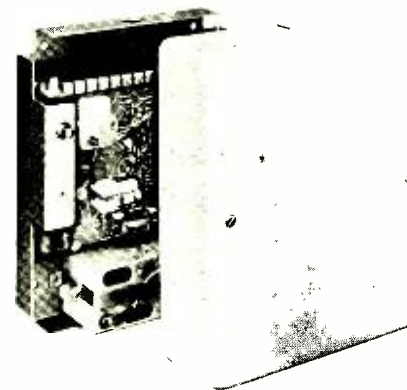

telephone rings are ignored. Sophisticated counting, audio-level and reset circuits reliably process potential threats. Audio detectors or speakers supplied cover as much as 2,500 feet each, depending on acoustics. Existing audio systems may be used with no additional wiring if

cables are shielded or twisted and run in conduit. The A-18 can handle one to twenty audio inputs to provide protection for a small shop or up to a 30,000-50,000 square-foot warehouse.—Mountain West Alarm Supply Co., 4215 North 16th St., Phoenix, AZ 85016.

CIRCLE 73 ON FREE INFORMATION CARD

**STEREO TUNER, model KT-7300:** features a dual-gate MOS-FET in the RF stage and exceptional stability even under the widest climatic changes of temperature and humidity. With FM sensitivity of 1.8 mV (10.3 dBf), the KT-7300 can handle signals as strong as 1 volt without overload. Phase-linear ceramic filters in the IF stage bring selectivity to a high 80 dB.

A new FM decoder, consisting of a multiplier and a linear phase shifter, has a useful bandwidth of over 1 MHz. Signal-to-noise ratio is 68 dB (stereo), 73 dB (mono).

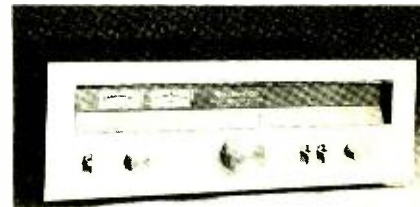

A phase-lock-loop circuit and individual LC filters for each channel provide 35 dB stereo separation 50 to 10,000 Hz with a solid 45 dB at the mid-range frequencies. Filters cut interference above 19 kHz, including the 19-kHz carrier, without affecting the musical frequencies. Other features include a 25-ms de-emphasis switch which gives perfect balance to Dolbyized FM broadcasts; two sets of outputs (one fixed, one adjustable), the first of which is fed to TAPE for the highest signal desirable; the second is fed to the amplifier for tuner play when a lower level may be preferred; and lastly, terminals for an oscilloscope with which to check and correct multipath distortion, accurate signal strength and zero-center tuning meters, a long, linear FM dial, as well as MPX filter and muting switches.—Kenwood, Dept. P, 15777 South Broadway, Gardena, CA 90248

CIRCLE 74 ON FREE INFORMATION CARD

**IC DIGITAL COLOR-BAR PATTERN GENERATOR, model 388** is a new unit, housed in hand-sized cabinet, weighs 12 ounces and delivers accurate signals for test and alignment of any color or black-and-white television receiver. It provides the following displays, projected on channels 2, 3 or 4: gated rainbow pattern for chrominance adjustment with ten standard color bars; single dot for static convergence adjustment; dot raster for final convergence, nonlinearity correction, pincushioning; single vertical line for horizontal centering; eight vertical lines for width and nonlinearity adjust-



ments: single horizontal line for vertical centering; eight horizontal lines for height and nonlinearity adjustment; single crossbar for centering and positioning; and crosshatch pattern for final convergence, pincushioning and nonlinearity correction.



Operates from two standard 9-volt batteries or rechargeable nickel-cadmium cells. Also featured, is an LED for power-on indication, crystal-controlled oscillator and timing circuits, for greater stability. \$99.95.—EICO Electronic Instrument Co., 283 Malta St., Brooklyn, NY 11207.

CIRCLE 75 ON FREE INFORMATION CARD

**STEREO AMPLIFIERS, models 300 and 300A.** The model 300 is a 300-watt stereo power amplifier kit designed for easy re-wiring into a 4-channel unit with a full complement of input and output functions. It is rated to deliver 150 watts per channel into 8 ohms, 20 Hz through 20 kHz, at less than 0.24% total harmonic distortion at rated power. Both channels are completely independent, with separate power supplies. Converted to quadriphonic operation, the amplifier delivers 75 watts per channel into 8 ohms.

**1 out of 2 who have it don't know it...**



21 million Americans have high blood pressure. But 50 percent of those who have it don't know it. When blood pressure goes higher than it should, and stays high, it sets the stage for heart attack or stroke. Most cases of high blood pressure can be controlled with drugs and other advances in treatment. That's why you should see your doctor regularly. Only he can tell if you need help.

A public service message from your Heart Association



# EIGHT INSTRUMENTS IN ONE

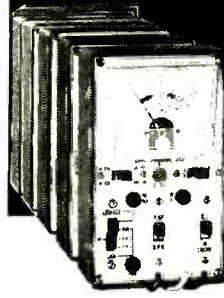

- Out-of-Circuit Transistor Analyzer
- Dynamic In-Circuit Transistor & Radio Tester
- Signal Generator
- Signal Tracer • Voltmeter
- Milliammeter
- Battery Tester
- Diode Checker

## Transistor Analyzer Model 212

Factory Wired & Tested—\$28.24  
Easy-to-Assemble Kit—\$19.21

**YOU DON'T NEED A BENCH FULL OF EQUIPMENT TO TEST TRANSISTOR RADIOS!** All the facilities you need to check the transistors themselves — and the radios or other circuits in which they are used — have been ingeniously engineered into the compact, 6-inch high case of the Model 212. It's the transistor radio troubleshooter with all the features found only in more expensive units. Find defective transistors and circuit troubles speedily with a single, streamlined instrument instead of an elaborate hook-up.

### Features:

Checks all transistor types — high or low power. Checks DC current gain (beta) to 200 in 3 ranges. Checks leakage. Universal test socket accepts different base configurations. Identifies unknown transistors as NPN or PNP.

Dynamic test for all transistors as signal amplifiers (oscillator check), in or out of circuit. Develops test signal for AF, IF, or RF circuits. Signal traces all circuits. Checks condition of diodes. Measures battery or other transistor-circuit power-supply voltages on 12-volt scale. No external power source needed. Measures circuit drain or other DC currents to 80 milliamperes. Supplied with three external leads for in-circuit testing and a pair of test leads for measuring voltage and current. Comes complete with instruction manual and transistor listing.

EMC, 625 Broadway, New York 12, N. Y.

Send me **FREE** catalog of the complete value-packed EMC line, and name of local distributor.

NAME \_\_\_\_\_ RE-1

ADDRESS \_\_\_\_\_

CITY \_\_\_\_\_ ZONE \_\_\_\_\_ STATE \_\_\_\_\_

# EMC

ELECTRONIC MEASUREMENTS CORP.  
625 Broadway, New York, N. Y. 10012



## "FERRET" TV MINI-ANALYZER FOR FAST STEP-BY-STEP TROUBLE SHOOTING

### SUB TUNER

VHF AND UHF TUNER FOR RAPID TESTING OF ALL CHANNELS. CALIBRATED GAIN ADJUSTMENTS PROVIDE FOR SIGNAL STRENGTH COMPARISON.

### DIGITAL GENERATOR

CRYSTAL CONTROLLED FOR GENERATING STABLE PATTERNS WHEN CONVERGING RED, GREEN AND BLUE GUNS. IDEAL FOR LINEARITY, PIN CUSHION, CENTERING, FOCUS AND ALL PICTURE ADJUSTMENTS.

### 40 MHz OUTPUTS

IF SIGNALS FROM DIGITAL GENERATOR AND SUB TUNER FOR STAGE-BY-STAGE ANALYZING AND TROUBLE SHOOTING.



SG 785 \$99.95

### GENERATOR SECTION

#### CROSS-HATCH

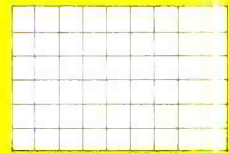

#### LINEARITY ADJUSTMENT

STANDARD FOR VERTICAL AND HORIZONTAL POSITIONING. PICTURE CONTRAST. IF BANDWIDTH TEST.

#### DOT PATTERN



#### CONVERGENCE ADJUSTMENT

STATIC AND DYNAMIC CONVERGENCE. BEAM ADJUSTMENTS.

The VHF/UHF section of the Ferret allows direct substitution of the TV's tuner for fast, positive localizing of front end trouble.

The crystal controlled digital circuitry assures complete accuracy of both the vertical and horizontal frequencies. Accuracy is better than .005%. Output from the generator may be coupled thru the tuner section or directly to the IF-video stages. Resolution is limited only by the picture quality of the TV receiver. Operates from 105 to 125 volts 50-60Hz.



2849 FULTON STREET, BROOKLYN, NY 11207  
PHONE: (212) 827-1500

### SOLD THRU DISTRIBUTORS ONLY

Please send me more information. J-7  
Name \_\_\_\_\_  
Address \_\_\_\_\_  
Code \_\_\_\_\_

CIRCLE 34 ON FREE INFORMATION CARD

www.americanradiohistory.com

**NEWS RELEASE 1976** **OFFICIAL TESTING LAB RATES ALLISON #1...** **NEW** **ALLISON 'OPTO XR-700'**

**the BEST of ALL Ignition Systems!**  
 \* The ALLISON "Opto" was Officially Rated #1 by a Foreign Government Testing Laboratory as the BEST "Fuel Saving" Ignition of ALL the Ignition Systems Tested, including Systems with C.D. "add-ons"!

Allison replaced the mechanical Breaker-Points and Condenser with a "Highly Accurate" Optical Control. A Beam of Light, passing through a specially designed "ROTOR" precisely triggers a Heavy-Duty "POWER MODULE" that BOTH "Charges and Fires" the Ignition Coil, with the "FASTEST" High Voltage RISE TIME, producing the MAXIMUM "HIGHEST ENERGY" SPARK available.

Since there is NO Mechanical Friction, there are NO Parts to ever WEAR or need replacing, and ONCE properly Timed, it should NEVER need any Maintenance! DWELL never needs adjustment, it is PRE-SET to supply the OPTIMUM Performance at BOTH High and Low Speeds. The RPM Capability of the "XR-700" is Factory Tested to 15,000 RPM.

The "High-Energy" SPARK INTENSITY and DURATION... permits the Positive FIRING of Spark-Plugs, even under the MOST ADVERSE conditions, results in more COMPLETE COMBUSTION and Eliminates "Engine Misfire", hence fewer exhaust Emissions, IMPROVED Fuel Mileage, a HIGHER Performance Level... and helps keep Plugs FROM FOULING, which greatly extends the Spark-Plug LIFE!

Only the Highest Grade (U.S. Made) Solid-State Components are used. UNAFFECTED by Moisture or Vibration! The Allison "XR-700" was engineered to OUTLAST the LIFE OF YOUR CAR!

"EASY-TO-FOLLOW" INSTALLATION.  
 (Not Necessary to Dismantle your Distributor.)

"CB" USERS: The XR-700 completely ELIMINATES the Major Cause of Primary (Ignition Noise) Interference.

**FACTORY-BACKED 10-YEAR WARRANTY.**  
FREE Unit Repair or Replacement on ANY Defects

**ORDER WITH CONFIDENCE...**  
 Remember, even if you PAY Three Times as much, you cannot get a better Ignition System than the "XR-700"!

**SAVE! ORDER FACTORY DIRECT.**  
 Send Check or M.O. Car Make, Year, No. Cyl. (4, 6, or 8-Cyl.)

**You may use your MASTER CHARGE or BANKAMERICARD.**  
 Send us (1) Your Number, (2) Interbank No., (3) Exp. Date.

**MC or BA Card Holders, ORDER BY TOLL FREE PHONE:**  
 (800) 423-6525, Ext. 2 (When in Continental U.S.A.)

**Before Buying ANY other Type Ignition System...  
 Send Postcard for FREE BROCHURE.**

If you have already installed a "Capacitive-Discharge" Ignition.  
 \* Convert Your "C-D" Unit to BREAKERLESS!  
**INCREASE ITS EFFICIENCY with "XR-CD"... Only \$34.95**

**America's Oldest and Largest Manufacturer of Opto-Electronic Ignition Systems.**

**ALLISON** \* Our BEST Salesmen... are the USERS of our ALLISON Systems!  
**AUTOMOTIVE CO.** 1267 -E9, East EDNA PL., COVINA, CAL. 91722

CIRCLE 65 ON FREE INFORMATION CARD

All of the audio circuitry, except for the output stages, is contained on 2 factory-wired and pre-tested circuit boards, permitting complete assembly of the amplifier in about 10 hours. Amplifier and speaker protection is afforded by volt-amp limiting, 8 B+ fuses, 4 speaker fuses, 2 thermal breakers, in addition to the AC line fuse. As supplied, the Stereo 300 is wired for maximum power output into 8- and 15-ohm loads. Alternative conversion through simple internal changes enables even greater power outputs into lower impedance loads, with proper volt-amp protection. Behind the black panel, provision is made for either two or four rear-lighted output meters as optional accessories.



with a 4-position meter range switch. Walnut veneer end panels are supplied and rack mounting bracket will be available as an accessory. Measures 18 1/8 inches wide by 14 3/8 inches deep by 7 3/8 inches high. \$489. The Stereo 300A comes already assembled \$699.99.—Dynaco Inc., Box 88, Blackwood, NJ 08012.

CIRCLE 76 ON FREE INFORMATION CARD

**PROFESSIONAL AIDS SHELF FILES**  
 KEEP MAGAZINES, CATALOGS, MANUALS, JOURNALS, DIRECTORIES AND REPORTS NEAT, ORGANIZED



Eliminate the clutter of loose magazines, catalogs, etc. Find what you want, when you want it by utilizing these handy shelf or desk top files.



STORE ON SHELVES

Available in 6 sizes from Reader's Digest to newspaper size. Constructed of heavy duty fibreboard. Attractive blue front panel. Adhesive identification labels included.



ORGANIZE YOUR DESK

Popular letter size: 11 1/2 x 9 x 3 3/4  
 10 for \$15.80  
 25 for \$28.97 Other sizes available  
 Shipped pre-paid Request Catalog  
 Canada, add \$1.00  
**PROFESSIONAL AIDS CO.**  
 1 S. WACKER DR., SUITE 177R  
 CHICAGO, ILL. 60606

CIRCLE 54 ON FREE INFORMATION CARD

DESK TOP INSTANT DATA SYSTEM

**FIND THOUSANDS OF FACTS AT COMPUTER SPEED**

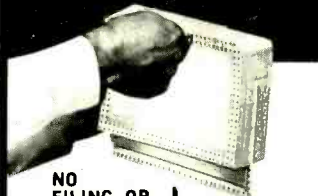

**NO FILING OR REFILING EVER!** | **COMPACT. EASY-TO-DO**

The modern rapid way to locate countless facts at your desk without thumbing thru files. Specially coded cards are used to record any information you want close at hand — technical data, formulas, abstracts, case hist., bibliographies. Obtain just what you need in seconds—any group separates automatically simply by inserting a rod. No slow inefficient cross filing... no mechanical parts... no special training... minimum set up time.

**30 DAY MONEY BACK GUARANTEE**

ONLY **\$38.00** POSTPAID  
 Basic package (200 cards, hand notcher, sorting rods, instructions).  
 Additional cards: 1000 for **\$57.00** postpaid. Sample Card Available

**FREE LITERATURE ON REQUEST**

Information Retrieval System, Div. of **PROFESSIONAL AIDS CO.**  
 1 S. WACKER DR., SUITE 176R  
 CHICAGO, ILL. 60606

CIRCLE 55 ON FREE INFORMATION CARD

For faster service

USE ZIP CODE

on all mail

**ANALOG MULTIMETER**

*continued from page 48*

sensitivity near 1 volt.

Figure 5-b shows the discrete differential amplifier. Its advantage lies in its voltage gain. It also buffers the input attenuator from the low impedance of the meter movement. Once again the FET is used to obtain the high impedance. A modern integrated version of the differential amplifier is shown in Fig. 5-c. An operational amplifier, buffered with FET followers on the inputs, is the amplifier.

The AC section of the TVM differs in a few characteristics from the VTVM. The placement of the rectifier within the circuit is the major difference between the two. The TVM rectifier is almost always placed after the amplifier, which must then have both good AC and DC characteristics. The type of rectifier is also changed. Figure 6 shows the various types of rectifiers used in the AC portions of TVM's. Figure 6-a is the simple input rectifier, much like that of the VTVM. This rectifier is peak responding. Its DC output must be divided by 1.414 to obtain the RMS value of a pure sine wave.

Figure 6-b is a bridge rectifier driven from the outputs of a differential amplifier. This circuit is average responding—the output must be multiplied by 1.1 to obtain the RMS value. Figures 6-c and 6-d are other common implementations of the average responding circuit. Both of these employ the operational amplifier to overcome the nonlinear characteristics of the diode at low voltages. Figure 6-c is a full wave, 6-d a half-wave rectifier.



# INTRODUCING



## The NEW PHLANGER KIT

Phil Spector's original "Big Hurt" sound is EXACTLY duplicated using PAIA's new constant time delay PHLANGER. This unit features a 1024 stage Charge Coupled Device analog shift register that exactly duplicates the effect of 2 tape recorders running out of synchronization.

Multiple user controls allow effects ranging from chorusing, voice doubling and reverb to full "Jet Plane" effects. Optional foot pedals provide hands free control of internal oscillator sweep speed or manual spectrum sweeping.

#1500.....PHLANGER Kit.....\$59.95  
(plus shipping for 4 lbs.)

**PAIA** - FREE CATALOG -  
ELECTRONICS DEPT. 1-R  
1020 W. WILSHIRE BLVD.  
OKLAHOMA CITY, OK 73116

CIRCLE 20 ON FREE INFORMATION CARD

## EXECUTIVE DIGITAL ALARM CLOCK KIT-ONLY \$29.95

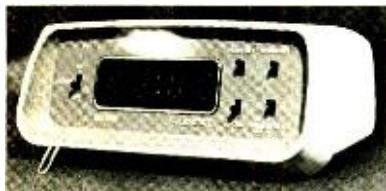

FAMOUS MAKE-LIMITED QUANTITY AVAILABLE  
ALL Parts Included

### FEATURES

- Delux Ivory Case
- 24 Hr. Alarm Set
- Easy To Read 3/4" LED'S
- AM/PM Indication

## DIGITAL ALARM CLOCK KIT-\$19.50



ALL PARTS INCLUDED

### FEATURES

- 24 Hr Alarm Setting • AM/PM Indication • Seconds Display • Snooze Alarm • 12 or 24 Hour Display • 50/60 Cycle Operation

N.J. Residents Add 5% sales tax. Send check or Money Order to:

**J.B. ELECTRONICS INC.**  
P.O. BOX 321 SHORT HILLS, N.J. 07078

CIRCLE 58 ON FREE INFORMATION CARD

The AC and DC attenuators of the TVM are usually the same, unlike those of the VTVM. When the attenuator is common, it must be compensated to attenuate accurately at both high and low frequencies. Figure 7 is a compensated attenuator used in a 10-megohm TVM. The capacitors create a capacitive divider with the same ratio as the resistors they shunt. If they were not used, the capacitive division ratio would depend entirely on the distributed capacitances of the resistors. These are substantial for high and negligible for low resistances. There is less than a decade attenuation across the first divider and a full decade across the last one.

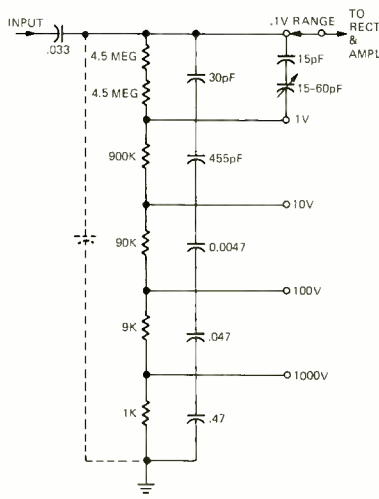

FIG. 7—THE INPUT ATTENUATOR of the Heathkit IM-104 as designed for AC operation. Capacitor shown in dotted lines represents stray resistances in the circuit.

The input to the attenuator is also AC coupled with a 0.033-mF capacitor. It serves to keep DC from the attenuator and therefore from the amplifier and rectifier, which respond to a combination of AC and DC. The total input capacitance of the TVM is somewhat greater than that of the capacitance in shunt with the divider because of other distributed capacitances (see the dotted capacitor in Fig. 7).

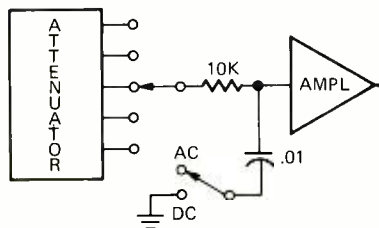

FIG. 8—SWITCHABLE FILTER used to keep AC out of the amplifier when the instrument is used to measure DC voltages.

TVM's using a common AC and DC attenuator have a filter (Fig. 8). It is switched into the attenuator output during DC and during AC operation. The filter helps remove AC signals from the amplifier input when the meter is operating in the DC mode. Although the meter theoretically does not respond to AC signals, excessive AC can disturb the amplifier enough to cause error in DC readings.

to be continued

Test Equip. Special Discount Price

**B&K** **EICO**  
**Leader**  
SENCORE

- RCA 110 FLYBACK TRANS. For Blk. & Wht. sets 18KV..... 95
- 110 TV DEFLECTION YOKE for all types TV..... 95
- "COMBINATION SPECIAL" RCA 110 FLYBACK & YOKE..... 95
- 90 COLOR YOKE for rect. 19 to 25 CRT's..... 95
- 70 COLOR YOKE for round color CRT's..... 95
- UHF TUNERS Transistor type used in all TV sets..... 95
- GE UHF TUNERS Transistor Type Model 85X4..... 95
- ADMIRAL TUNER Model 94C39 (Series)..... 95
- ADMIRAL TUNER Model T94C44 (Transistor)..... 95
- GE TV TUNER Model #EP86X11 (Series)..... 95
- PHILCO UHF/VHF TUNER Transistor type..... 95
- ZENITH TUNER Model 175-1164 or 175-1151..... 95
- BLUE LATERAL MAGNET ASSY Repl. for most TV..... 79
- COLOR DELAY LINE..... 69
- Used in most TV..... 95
- ZENITH SILICON STICK RECTIFIER Part # 103-213..... 95
- ZENITH TRIPLER Part # 212-109-Same as 8X1591..... 95
- 3-POLARIZED CHEATER CORDS Grey..... 100
- COLOR POWER TRANSFORMER (CA Part # 26R150)..... 79
- 2-COLORBURST CRYSTALS (3579, 45KC)..... 89
- 3-COLOR TV RECTIFIER 6500KV..... 95
- 6-TV ALIGNMENT KIT most popular type..... 79
- 4-TV ALIGNMENT KIT useful asst..... 100
- 5-DUAL DIODE most popular type (Common or Series)..... 200
- VU "T" PANEL METER 0-20 db Scale..... 29
- CO-AX CABLE RG59U (Blk.) (250-\$10.00) 50..... 69
- HI VOLTAGE POWER TRANSISTOR Equip. to Hep 707..... 29
- TRANSISTOR RADIO asst. types (good, bad, broken, as-is)..... 50
- TAPE RECORDERS asst. types (good, bad, broken, as-is)..... 400
- 100' GREY SPEAKER..... 200
- WIRE..... 200
- UNIVERSAL TV ANTENNA back of set type (3 section)..... 299
- 3-ZENITH VIDEO AMPLIFIER Part # 121-748..... 200
- WAHL CORDLESS SOLDER IRON (complete with charger)..... 1795
- 8" HEAVY DUTY 100Z. SPEAKER ceramic type 8 ohm..... 50
- 6"x9" HEAVY DUTY 100Z SPEAKER Cer. Type 8 Ohm..... 50
- STEREO HEADPHONES HI FI Quality with plug..... 95
- TACHOMETER 2 1/4" SQUARE PANEL METER LVDC-0-6000 RPM..... 200
- CASSETTE TYPE MIKE Universal Plug 200 Ohms..... 299
- 5 ZENIER DIODES 1N4757A-1 W-50 V..... 100
- 4-ASSTD PHILCO PUSH PUSH TYPE SWITCHES..... 259
- 2-HEP S0015 SILICON TRANSISTORS..... 100
- 1-HEP S5004 SILICON NPN TRANSISTOR..... 100
- 1-HEP S5011 OR HEP S5012 HV TRANSISTORS..... 100
- TRANSISTOR SPECIALS SK3006, SK3010, SK3020..... 120
- TRANSISTOR SPECIALS SK3122, SK3124..... 120
- TRANSISTOR SPECIALS SK3009, SK3021, SK3040..... 120
- 6E IC3 OR IC4 INTERGRAATED CIRCUIT..... 100
- 6-SILICON RECTIFIERS 1 Amp-100V PIV..... 100
- 7 TUBE AM FM STEREO AMPLIFIER CHASSIS complete with tubes as is..... 995
- DELUXE PILLOW SPEAKER with plug & volume control..... 249
- 2-12BH & RCA TUBES..... 100
- 8-MINI PILOT BULBS (6.3V-30Ma) or (6.3V-150Ma)..... 100
- 3"x5" SPEAKER..... 19
- TV replacement..... 100
- 1-ELECTROLYTIC COND. 300MFD-250V..... 100
- 3-ELECTROLYTIC COND. 100/80, 20 Mfd-300V..... 200
- 3 PACK C-60 CASSETTE fine quality..... 150

Minimum Order \$5.00 Immediate Delivery

**BROOKS RADIO & TV CORP.**  
529 Columbus Ave., New York, N.Y. 10024  
TELEPHONE 212-874 5600

CIRCLE 59 ON FREE INFORMATION CARD



INTERNATIONAL FM 2400CH

## FREQUENCY METER for testing mobile transmitters and receivers



- Tests Predetermined Frequencies 25 to 1000 MHz
- Extended Range Covers 950 MHz Band
- Pin Diode Attenuator for Full Range Coverage as Signal Generator
- Measures FM Deviation

The **FM-2400CH** provides an accurate frequency standard for testing and adjustment of mobile transmitters and receivers at predetermined frequencies.

The FM-2400CH with its extended range covers 25 to 1000 MHz. The frequencies can be those of the radio frequency channels of operation and/or the intermediate frequencies of the receiver between 5 MHz and 40 MHz.

Frequency Stability:  $\pm .0005\%$  from  $+50^{\circ}$  to  $+104^{\circ}$ F.

Frequency stability with built-in thermometer and temperature corrected charts:  $\pm .00025\%$  from  $+25^{\circ}$  to  $+125^{\circ}$  (.000125% special 450 MHz crystals available).

Self-contained in small portable case. Complete solid state circuitry. Rechargeable batteries.

**FM-2400CH** (meter only) ..... \$595.00  
**RF crystals** (with temperature correction) .... 24.00 ea.  
**RF crystals** (less temperature correction) ..... 18.00 ea.  
**IF crystals** ..... catalog price

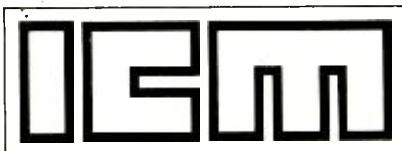

International Crystal Manufacturing Company, Inc.  
 10 North Lee Oklahoma City Oklahoma 73102

CIRCLE 68 ON FREE INFORMATION CARD

## VIDEO GAMES

continued from page 42

mode (Robot) has a controllable skill level. The Indy 500 Road Race Game for 1 or 2 players has realistic sounds to duplicate engine acceleration and crashes, and appears to be one of the games in both the Game Table and *Video Action IV*. The models IIA and III play 2 or 4 player tennis, or hockey. The color display on the *Video Action* game screen is a rainbow pattern rather than discrete coloration of images.

The Fact game displays questions and answers in alphanumeric on your TV screen. It may have a microprocessor since it uses cartridges to program the mode of operation. The unit comes with 2 cartridges, and 5 more are available. One or two people can pit their knowledge against each other or against the machine. You can test your knowledge in hundreds of planned categories with two categories in each cartridge. Also, *learning* cartridges to improve reading, math, history or other skills, are planned. Multiple-choice answer buttons are used.

**Videomaster:** All of these games are manufactured in England. Some of the games in the Rally and Olympic models are different than the other games surveyed, and no upper or lower court boundaries are displayed. The 6000 seems to be a standard GI IC game, but in a fancy aluminum case with a lever control for each player.

**Visulex:** This kit was the subject of a detailed 3-part article in the June, July and August 1976 issues of *Radio-Electronics*. You can order anything from complete \$6 construction plans and individual parts, to the everything package for \$129.50 that includes the main circuit board, scoring circuit board, all parts, hardware, wire, cable, controls, power supply and main cabinet with remote player control boxes. **R-E**



## GO DIGITAL, GO DANAMETER®

(The New VOM For Today's Needs.)

- 0.25% Accuracy
- Full Overload Protection
- Really Drop-Proof
- Full One Year Battery Life



Dana Laboratories, Inc.

2401 Campus Dr, Irvine, Ca 92715, (714) 833-1234  
 CIRCLE 62 ON FREE INFORMATION CARD



# next month

FEBRUARY 1977

- Preview of 40-channel CB gear
- How manufacturers plan to handle trade-ins or conversions on 23-channel gear
- How to tune 40 channels. Rotary, Keyboard, Thumbwheel
- Directory of manufacturers
- Antennas for 40 channels. Can present antennas be used?
- New FCC regulations



**now... 97% ACTIVE INGREDIENTS**  
*Plus*  
**WARMER SPRAY FOR MORE CLEANING POWER**

TUN-O-WASH has long been the industry standard in tuner degreasers. Now, it's better and more economical than ever.

No, we haven't tampered with the famous TUN-O-WASH formula. That's too good to change. What we have changed is the propellant. We now use carbon dioxide (CO<sub>2</sub>) as a propellant. This permits us to fill the can with 97% active ingredients, compared with only 65% active ingredients before this development. The can is the same size, but you get more cleaning power for your money.

There are other advantages to using CO<sub>2</sub> as a propellant. **FIRST**, the spray comes out 10° warmer. Everyone knows that heat increases solvent action. **SECOND**, the particles of solvent come out in larger drops, making for a wetter spray. And, finally, CO<sub>2</sub> enables us to maintain a uniform 70 pound pressure until the can is completely empty.

This is another first from the electronics industry's leading chemical manufacturer.

**CHEMTRONICS INCORPORATED**  
 43 HOFFMAN AVE., HAUPPAUGE, N. Y. 11787 • (516) 562-3322

CIRCLE 26 ON FREE INFORMATION CARD

## Put Professional Knowledge and a COLLEGE DEGREE

in your Electronics Career through

# HOME STUDY

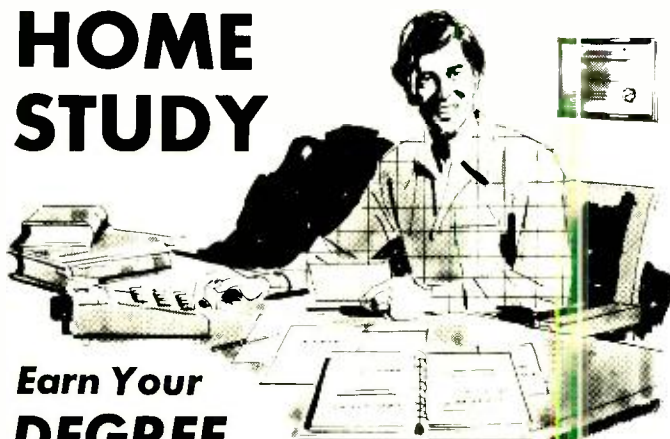

## Earn Your DEGREE

by correspondence, while continuing your present job. No commuting to class. Study at your own pace. Learn from complete and explicit lesson materials, with additional assistance from our home study instructors. Advance as fast as you wish, but take all the time you need to master each topic. Profit from, and enjoy, the advantages of independent study.

The Grantham correspondence degree program in electronics is comprehensive. It begins with basics, written in very simple language, and continues through the B. S. E. E. degree level. Throughout the entire program, heavy emphasis is placed on clear explanations written in great detail, progressing from the simple to the complex, in easy steps.

Our free bulletin gives complete details on the curriculum, the degrees awarded, the requirements for each degree, and how to enroll.

### GRANTHAM SCHOOL OF ENGINEERING

2000 Stoner Ave., Los Angeles CA 90025

● Telephone (213) 477-1901 ●

Worldwide Career Training thru Home Study

Mail the coupon below for free bulletin

**Grantham School of Engineering** RE 1-77  
 2000 Stoner Ave., Los Angeles, CA 90025

I have been in electronics for \_\_\_\_\_ years. Please mail me your free bulletin which gives details concerning your electronics degree programs.

Name \_\_\_\_\_ Age \_\_\_\_\_

Address \_\_\_\_\_

City \_\_\_\_\_ State \_\_\_\_\_ Zip \_\_\_\_\_

CIRCLE 9 ON FREE INFORMATION CARD

# market center

**CLASSIFIED COMMERCIAL RATE** (for firms or individuals offering commercial products or services). **\$1.40 per word** . . . minimum 15 words.

**NONCOMMERCIAL RATE** (for individuals who want to buy or sell personal items) **85¢ per word** . . . no minimum.

**ONLY FIRST WORD AND NAME** set in bold caps. Additional bold face (not available as all caps) at 10¢ per word. Payment must accompany all ads except those placed by accredited advertising agencies. 10% discount on 12 consecutive insertions, if paid in advance. All copy subject to publisher's approval. Advertisements using P.O. Box address will not be accepted until advertiser supplies publisher with permanent address and phone number. Copy to be in our hands on the 26th of the third month preceding the date of the issue (i.e. August issue closes May 26). When normal closing date falls on Saturday, Sunday or a holiday, issue closes on preceding working day.

## FOR SALE

**RECONDITIONED** test equipment. \$0.50 for catalog. **WALTER'S TEST EQUIPMENT**, 2697 Nickel, San Pablo, CA 94806

**LOW cost digital/analog test equipment.** Exceptional values. Free catalog. **SALEN ELECTRONICS**, P.O. Box 82, Skokie, IL 60076

**12" ALL PURPOSE  
1 VOLT P TO P  
GREEN PHOSPHOR  
VIDEO DISPLAY**

IDEAL UNIT FOR ANY DIGITAL OR GRAPHICS APPLICATION

**\$150** Add \$10 for packing and shipping in continental US

**COMPUTER WAREHOUSE STORE** WRITE FOR OUR CATALOG c/o Dept.R  
584 Commonwealth Ave. Boston 02215

**SEMICONDUCTOR** and parts literature. **J. & J. ELECTRONICS**, Box 1437R, Winnipeg, Manitoba, Canada. U.S. Inquiries Invited.

**SURPRISE!** Build inexpensively, the most unusual test instruments, futuristic gadgets using numerical readouts! Catalogue free! **GBS**, Box 100B, Greenbank, WV 24944

**CANADIAN** discount and factory clearouts catalog. Top brand stereo equipment, calculators, test gear, CB & communications, telephones. Factory dumps—government surplus. Amazing bargains. Unusual items. Rush \$1. **ETCO-RE**, 521 5th Ave., NYC, 10017

**PICTURE TUBE MACHINE**  
We buy and sell NEW and USED CRT colorizing machinery. COMPLETE TRAINING. Buy with CONFIDENCE from the ORIGINAL MFR.

For complete details send name address, zip code to:  
**LAKE SIDE INDUSTRIES**  
3520 W Fullerton Ave  
Chicago, Ill 60647  
Phone 312-342-3399



**NEW** Canadian Magazine, "Electronics Workshop", \$5.00 yearly, sample \$1.00. **ETHCO**, Box 741 "A", Montreal

**FREE** catalog. IC's, Semi's. **CORONET ELECTRONICS**, 649A Notre Dame W., Montreal, Que. Canada, H3C-1H8. US Inquiries.

**RADIO & TV tubes** 36¢ each. One year guaranteed. Plus many unusual electronic bargains. Free catalog. **CORNELL**, 4217-E University, San Diego, CA 92105

**MANUALS** for Govt. surplus radios, test sets, scopes, List 50¢ (coin). **BOOKS**, 7218 Roanoke Drive, Washington, DC 20021

**UNSCRAMBLES:** We manufacture one of the finest police code unscramblers on the market. Our prices are very competitive and our service is the best. For further information call or write: **DON NOBLES ELECTRONICS, INC.**, Dept. RE, Rt. 7, Box 265B, Hot Springs, AR 71901

**EC-101 CURVE TRACER**  
STILL BY FAR THE LOWEST COST FULL FUNCTION CURVE TRACER ON THE MARKET. ATTACHES TO YOUR SCOPE IN SECONDS. USED BY EDUCATORS, PROFESSIONALS AND HOBBYISTS ALL OVER THE WORLD. 30 DAY MONEYBACK GUARANTEE.

**lab science** STILL ONLY \$39.50 ADD \$2 PAH COLO. RES. ADD 3% SALES TAX

PO BOX 1972, BOULDER, COLO. 80306

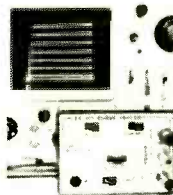

**DESCRAMBLERS:** Several professional models that work with all scanners. Tone encoders/decoders. Scanmate, AAPP, radar detectors, Big Ears, alarms, books, kits, parts. Catalog 25 cents. **KRYSTAL KITS**, Box 445, Bentonville, AR 72712

**TV picture tubes**—ASE manufactures over 2200 types, B/W and color. **ALLIED SALES**, Dept. 43, Pimento, IN 47886. (812) 495-6555.

**NON semi surplus.** Monthly picture flyer. Quality. Low price. Send 25¢. U.S. only. **STARTRONICS**, Box 683, McMinnville, OR 97128

**SOLID-STATE** television recorder electronic unit with documentation. \$21.45. **MADISON ELECTRONICS COMPANY, INCORPORATED**, Box 369, D102, Madison, AL 35758

**NEW DIGITAL COLOR CONVERGENCE GENERATOR**

Uses latest CMOS-LSI technology. For servicing Color TV, etc. Selects up to 16 patterns. As low as \$39.95 (kit). Plans Kit or Wired \$5.00. RF & Video output. 2 Yr. Warranty.

SEND FOR DATA NOW. BOX 393  
**SCIENCE WORKSHOP** BETHPAGE, N.Y. 11714



**FREE** catalog. Calculators, digital thermometers, ultrasonics, kits, strobes, NiCads, LED's, transistors, IC's. Unique components. **CHANEY'S**, Box 27038, Denver, CO 80227

**FOR real:** Military-industrial quality parts, low prices, no junk. Free catalog. **BRAND X**, Rt. 3, Box 223, Ontario, OR 97914

# Olson electronics

Parts and Accessories

SPECIALIZING IN ELECTRONICS FOR 35 YEARS



**Voice Activated Switch**

XM-566  
Reg. 1.98

**159**

Activates lights, tape recorders, etc. Comes with 5" leads. 3 x 1". Operates on 4.5 VDC. Shpg. wt. 1/2 lb.



**Under Dash LOCKMOUNT**

Reg. 2.50

**179**

LAU-344

Locks CB or player in place. Slides in & out. 6 x 3/4 x 7". 6 or 12 VDC. 2 lbs.



**Color TV Tuner Cleaner**

Reg. 1.49

**53¢**

TL-459

Cleans and lubricates control & contact points. 6 oz can. 1/2 lb.



**BLACK LIGHT BULB**

Reg. 1.49

**\$1 49¢**

XM-291

Screw into any ordinary socket. Light up posters, decorations, etc. Shpg. wt. 1/2 lb.



PARTS & COMPONENTS	REG.	SALE
1/4 RPM Timing Motor, 117 V. AC	MO-277	49 30
1 RPM Timing Motor, 117 V. AC	MO-289	49 30
8 RPM Reversible Motor, 117 V. AC	MO-393	250 99
Tubular Capacitor Kit, 100 Pcs	CC-229	200 1.29
Ceramic Capacitor Kit, 100 Pcs	CC-211	149 1.19
100 Ceramic Capacitors, values clearly marked	CC-210	129 80
50 Asst. Electrolytic Capacitors, Axial/Radial	CO-407	500 2.00
100 Asst. Carbon Resistors, 1/4-1/2-1 Watt Sizes	RR-077	179 1.00
5 Asst. SCR's, 15 V. and Up, 100 MA to 1.6 AMP	TR-298	179 1.00
500 MW Zener Diodes, 4-3-6-3-9-1-12 & 15 Volts	DI-052	100 50
3 Unijunction Transistors, 40 V, 375 MW, 4 DN'S	TR-441	129 50
L.E.D. Pkg. of 5 Red, 2 Volt, 5 MA	PL-233	119 60
Ultra-Mini L.E.D. Pkg. of 5 Red, 2 V, 5 MA	PL-289	129 70
TI Calculator Key Board, 20 Keys	XM-523	500 1.60
3 1/2" Digit Liquid Crystal Display	KM-371	1000 3.00
Darlington Amp. Transistor Kit, 6 Transistors	TR-507	200 1.50
Photo Transistor, 5 Pieces- Epoxy Type	TR-502	100 60
6 Amp. Full Wave Bridge Rectifier 50 PIV	DI-057	120 80
6 Amp. Full Wave Bridge Rectifier 400 PIV	DI-058	190 100
PNP Transistor Assortment Pkg. of 10	TR-445	100 60
NPN Transistor Assortment Pkg. of 10	TR-446	100 60
7-Segment L.E.D. Display 3 In. Green	XM-341	2.69 1.00
7-Segment L.E.D. Display 3 In. Red	XM-370	2.00 1.00
7-Segment L.E.D. Display 3 In. Yellow	XM-342	2.49 1.00
Micro Type Switch Kit, 7 Assorted	SW-430	1.89 1.49
Knob Kit, 25 Pcs. Assorted	KM-030	100 69
Hobby Motor Kit, 3.6 V. DC, Pkg. 5	MO-333	59 49
<b>TOOLS — SPECIAL AND PRACTICAL</b>		
Wire Wrap Tool, 30 Ba Wire on .025 Post	TL-845	2.60 2.00
IC Insertion/Extraction Tool	TL-846	1.25 1.00
IC Plug-in Test Adapter	TE-396	2.60 2.00
12 Volt DC Soldering Iron, Pencil Tip	TL-793	4.00 3.00
Oymo Label Maker, Uses 1/4 in. Tape	TL-752	1.89 90
Double Face Foam Tape 1/4 x 52 In.	TA-903	1.00 80

**FREE CATALOG**

OLSON ELECTRONICS, 250 S. FORGE ST., DEPT LT, AKRON, OHIO 44327

NAME \_\_\_\_\_

ADDRESS \_\_\_\_\_

CITY \_\_\_\_\_ STATE \_\_\_\_\_

ZIP \_\_\_\_\_

Free PA Catalog  Send Olson Catalog  Ship The Following:

How Many	Stock Number	Description	Price	Total

ENCLOSE POSTAGE AND SALES TAX

**CIRCLE 1 ON FREE INFORMATION CARD**

RADIO-ELECTRONICS



**DIGI-KEY CORPORATION**  
Quality Electronic Components  
Double-Digit Discounts  
Save You Even More

2102-1	8080A	LM3909
\$1.99	\$24.95	69¢

**NATIONAL SEMICONDUCTOR CLOCK MODULES**

MA1010A 12 Hour (AM-PM) Version . . . \$13.00  
MA1010C 24 Hour Version . . . \$13.00



**0.84" High LED Digits**



MA1002A 12 Hour (AM-PM) Version . . . \$10.50  
MA1002C 24 Hour Version . . . \$10.50

**0.5" High LED Digits**



Special transformer and 6 switches,  
when ordered with module add \$3.45.

Special transformer and 6 switches  
when ordered with module add \$3.45

**Hobby-Wrap-30 \$5.95**

Strips, Wraps and Unwraps 30 ga. wire on standard wire wrapping pins



**MA1002 & MA1010 Series Electronic Clock Modules**

The MA1002 & MA1010 Series Electronic Clock Modules are assembled and pretested modules which combine a monolithic MOS-LSI integrated clock circuit, 4-digit LED display, power supply and other associated discrete components on a single printed circuit board to form a complete electronic clock movement. The user need add only a transformer and switches to construct a digital clock for application in clock-radios, alarm or instrument panel clocks. Time-keeping may be from 50 or 60 Hz inputs and 12 or 24 hour display formats may be chosen. Direct LED drive eliminates RF interference. Time setting is made easy through use of "Fast" and "Slow" scanning controls.

The MA1002A & MA1010A have a 12 hour display with an AM and PM indicator. The MA1002C and MA1010C have a 24 hour display.

Features include alarm "on" and "PM" indicators, "sleep" and "snooze" timers and variable brightness control capability. The modules are extremely compact, the MA1002 measuring 1.375" by 3.05", the MA1010 measuring 1.75" by 3.75". This small size is achieved by bonding PPA-1 to the back of the circuit board.

It is highly recommended that the transformer be ordered with the clock module as it is a special dual secondary type not otherwise readily available.

**Double Digit Discounts Save You Even More!**

**ACE201-K \$24.95**  
1,032 SOLDERLESS PLUG-IN THE POINTS  
CAPACITY: 1 P 7 T 12 14-PIN DIP'S  
TWO 5-way binding posts  
Size: 4.9" x 1.6" by .75"  
Kit form

**WIRE WRAPPING WIRE**  
Red or Black Kynar insulated pre-cut and stripped 30 ga. wire  
of insulation is removed from each end

Insulation Length	No. in Pkg.	Price per Pkg.
1.0"	100	\$2.50
2.0"	100	\$2.60
2.5"	100	\$2.65
3.0"	100	\$2.70
3.5"	100	\$2.75
4.0"	100	\$2.80
4.5"	100	\$2.90
5.0"	100	\$3.00
6.0"	50	\$1.60
7.0"	50	\$1.70
8.0"	50	\$1.80
9.0"	50	\$1.90
10.0"	50	\$2.00
15.0"	50	\$2.50

**SLIDE SWITCHES**

Single Pole Single Throw	.15 1.20/10 10.00/C
Double Pole Double Throw	.23 2.00/10 19.00/C

**BATTERY HOLDERS**

1-AA .25c
2-AA .42c
1-C .25c
2-C .42c
1-D .35c
2-D .55c

**BISHOP GRAPHICS Printed Circuit Drifting Aids are now available from Digi-Key**

**RADIAL ELECTROLYTICS**

47/50V .08	65/10	22/50V	12 1.00/10	330/2-W	1.86/10
1/50V .08	65/10	100/16 3V	09 75/10	470/1HR	1.71/10
2/250V .08	65/10	100/10V	10 77/10	470/1-W	1.81/10
3/3.50V .08	65/10	100/16V	11 85/10	470/2-W	2.35/10
4/7.35V .08	65/10	100/25V	13 1.10/10	1000/0V	1.96/10
4/7.50V .08	68/10	100/50V	21 1.71/10	1000/5V	2.35/10
10/1016V .08	65/10	220/10V	13 1.08/10	1000/25V	3.33/10
10/25V .08	65/10	220/16V	15 1.15/10	2200/0V	3.33/10
10/50V .10	75/10	220/25V	21 1.7/10	2200/5V	4.30/10
22/16V .08	67/10	220/50V	29 2.35/10	2200/25V	4.67/10
22/25V .09	70/10	330/10V	15 1.16/10	3300/16V	7.14/10
		330/16V	21 1.66/10		

**INTEGRATED CIRCUITS - TTL, CMOS, LINEAR & MOS**

7400 21	7476 32	74181 2.15	4012 .23	4520 1.14				
7401 21	7480 70	74182 7.9	4527 1.68	7401 21	7480 70	74182 7.9	4014 .96	4528 8.88
7402 21	7482 70	74184 2.19	4015 .96	4528 8.88				
7403 21	7483 70	74185 2.19	4016 .96	4528 8.88				
7404 21	7485 89	74188 3.50	4018 .40	2102-1	7486 28	74189 3.50	4017 1.05	9080A 24.99
7405 25	7486 28	74189 3.50	4017 1.05	CA3046 7.75				
7406 25	7489 2.19	74190 1.23	4019 .23	LM2111N 1.25				
7407 25	7490 44	74191 1.23	4019 .23	LM309K 1.80				
7408 21	7491 70	74192 8.8	4020 1.14	LM324A 1.28				
7409 21	7492 80	74193 8.8	4021 1.14	LM340T-5 1.25				
7410 21	7493 44	74194 8.8	4022 .96	LM340T-6 1.25				
7411 21	7494 70	74195 8.8	4023 .23	LM340T-7 1.25				
7412 21	7495 70	74196 8.8	4024 .84	LM340T-8 1.25				
7413 25	7496 70	74197 8.8	4025 .23	LM340T-12 1.25				
7414 89	74100 1.28	74198 1.49	4026 1.68	LM340T-15 1.25				
7415 25	74107 30	74199 1.49	4027 .40	LM340T-18 1.25				
7416 25	74109 33	74200 1.09	4028 .69	LM340T-24 1.25				
7417 25	74121 35	74201 1.14	4029 1.14	LM3900N 8.88				
7418 25	74122 44	74202 1.14	4030 2.3	LM3909N 6.99				
7419 25	74123 61	74203 67	4033 1.51	MC1456V 1.00				
7420 25	74125 40	74204 67	4034 3.50	MC1458V 5.3				
7421 25	74126 40	74205 67	4035 1.14	MC3302P 1.15				
7422 33	74132 70	8093 40	4040 1.14	NE536T 3.24				
7423 28	74141 88	8094 40	4041 7.9	NE540V 2.04				
7424 21	74145 70	8095 67	4042 7.9	NE555V 4.8				
7425 21	74147 1.63	8096 67	4043 70	NE566A 8.8				
7426 30	74148 1.30	8097 67	4044 70	NE568B 3.83				
7427 25	74150 1.16	8098 67	4046 1.86	NE561B 3.83				
7428 21	74151 70	8099 67	4049 1.6	NE562B 3.83				
7429 21	74153 65	75450 8.8	4050 40	NE565A 2.25				
7430 21	74154 1.03	75451 61	4051 1.26	NE566V 1.28				
7431 21	74155 70	75452 61	4052 1.26	NE567V 1.36				
7432 70	74156 70	75453 61	4053 1.26	uA700CV 4.4				
7433 30	74157 70	75454 61	4060 1.58	uA710CA 4.4				
7434 70	74160 8.8	75459 81	4066 7.9	uA711CA 5.3				
7435 70	74161 8.8	75462 84	4071 1.23	uA723CA 60				
7436 21	74162 88	75493 109	4072 23	uA732CA 7.5				
7437 21	74163 88	75494 119	4073 23	uA741 CV 4.4				
7438 21	74164 96	82525 2.19	4075 23	uA747 CA 70				
7439 21	74165 1.15	4090 23	4081 23	uA748 CV 4.4				
7440 21	74166 1.26	4001 23	4082 23	uA780CCU 1.25				
7441 21	74170 2.64	4002 23	4502 7.9	uA780CCU 1.25				
7442 30	74173 1.42	4006 1.23	4510 1.14	uA780CCU 1.25				
7443 30	74174 90	4007 23	4511 1.65	uA781CCU 1.25				
7444 30	74175 93	4008 7.9	4514 2.80	uA781CCU 1.25				
7445 30	74176 7.9	4009 4.4	4515 2.80	uA781CCU 1.25				
7446 30	74177 7.9	4011 4.4	4516 1.23	uA7824CU 1.25				
7447 30	74180 70	4011 23	4518 1.14					

**WIRE WRAPPING WIRE IN BULK**  
Red or Black 30 ga. Kynar

100' \$2.00	500' \$8.50	1000' \$15.00
-------------	-------------	---------------

**ENTIRE ROCKWELL CALCULATOR LINE ON DISCOUNT IN OUR LATEST CATALOG**

**MOLEX PINS**  
Make your own IC sockets on PC board

85/C	8.20/M	38.20/5M	275.00/50M
------	--------	----------	------------

**SILICON DIODES**

1N4001	64/10	5.50/C	\$49/M
1N4002	5.64/10	5.40	\$51/M
1N4003	68/10	5.80/C	\$52/M
1N4004	70/10	5.95/C	\$54/M
1N4005	82/10	7.05/C	\$63/M
1N4006	90/10	7.75/C	\$69/M
1N4007	99/10	8.60/C	\$77/M
1N4148	40/10	3.50/C	\$29/M

**Double Digit Discounts Save You Even More!**

**RESISTOR ASSORTMENTS**

See all 10% .5% .1% .1% .1% 10 thru 5 & 22 meg (350 pcs)	\$12.00
See all 10% .5% .1% .1% .1% 2.2 thru 22 meg (425 pcs)	\$12.00

**PERF BOARD**  
0.1" spacing between holes

4 1/2" x 6"	\$1.71
4 1/2" x 17"	\$4.25

**TERMINALS**  
for above perf board  
\$1.50/C

**LED LAMPS**

NSL5053 T1 1/4	18 \$15/C
NSL5056 T1 1/4	18 \$15/C

**LED DISPLAYS**

FND357 CC 375'	-\$1.75
FND500 CC 500'	-\$1.75
FND 507 CA 500	-\$1.75
FND800 CC 800'	-\$3.50
FND807 CA 800'	-\$3.50

**DATA BOOKS**

**TTL DATA BOOK**

**DATA BOOKS**

TTL IC's 595 p.	\$4.00
Linear IC's 957 p.	\$5.00
CMOS IC's 256 p.	\$3.00
Transistors 288 p.	\$3.00
Memory IC's 592 p.	\$3.00
Interface IC's 464 p.	\$4.00
Volt. Regs. 128 p.	\$3.00
Linear Appl. 1 432 p.	\$4.00
Linear Appl. 2 246 p.	\$3.00
Audio 196 p.	\$3.00

**AXIAL ELECTROLYTICS**

47/10V .11	90/10	33/25V	14 1.15/10	330/10V	2.35/10
1/30V .11	90/10	33/50V	19 1.52/10	330/2-W	2.54/10
3.3/35V .12	95/10	47/16V	14 1.15/10	470/1-W	2.55/10
3.3/50V .12	100/10	47/25V	17 1.30/10	470/2-W	3.00/10
4.7/25V .12	90/10	47/50V	17 1.30/10	1000/0V	2.81/10
4.7/35V .12	95/10	100/10V	14 1.13/10	1000/5V	3.15/10
4.7/50V .12	100/10	100/16V	17 1.30/10	1000/25V	4.50/10
10/25V .12	100/10	100/25V	20 1.55/10	2200/0V	3.96/10
10/50V .14	115/10	100/50V	29 2.38/10	2200/5V	4.95/10
22/16V .12	100/10	220/10V	18 1.42/10	2200/25V	6.36/10
22/25V .13	105/10	220/16V	20 1.55/10	3300/6V	7.63/10
22/50V .17	132/10	220/25V	29 2.35/10	4700/6V	8.70/10
33/16V .12	100/10	220/50V	40 3.23/10	10000/10V	9.19/10
		330/10V	14 1.16/10		

**WIRE-WRAPPING TOOL \$5.95**  
Wraps, Unwraps & Strips 30 ga. Wire

**1/4 & 1/2 WATT 5% CARBON FILM RESISTORS**  
5¢ each in multiples of 5 per value  
\$1.70/100 & \$12.00/1000 of same value  
1 ohm thru 1.0 megohm

**I.C. SOCKETS**

8 Pin Solder	1.60/10
14 Pin Solder	2.00/10
18 Pin Solder	2.75/10
24 Pin Solder	3.60/10
28 Pin Solder	4.125/10
40 Pin Solder	6.00/10
8 Pin W-W	2.10/10
14 Pin W-W	2.50/10
18 Pin W-W	3.25/10
24 Pin W-W	4.50/10
28 Pin W-W	5.10/10
40 Pin W-W	7.25/10

**HARDWARE**

2-56 1/4 Screw	99/C	7.20/M
2-56 1/2 Screw	99/C	7.65/M
4-40 1/4 Screw	55/C	3.60/M
4-40 1/2 Screw	69/C	7.00/M
6-32 1/4 Screw	65/C	4.40/M
6-32 1/2 Screw	75/C	4.85/M
8-32 3/8 Screw	90/C	5.85/M
8-32 5/8 Screw	99/C	7.00/M
2-56 Hex Nut	55/C	3.60/M
4-40 Hex Nut	55/C	3.75/M
6-32 Hex Nut	60/C	4.00/M
8-32 Hex Nut	60/C	4.15/M
No. 2 Lockwasher	85/C	5.75/M
No. 4 Lockwasher	85/C	3.00/M
No. 6 Lockwasher	85/C	3.00/M
No. 8 Lockwasher	85/C	3.00/M

**DOUBLE-DIGIT DISCOUNT \$5 MEDULE**

Merchandise	Discount	Merchandise	Discount
\$ 0.00-\$29.99	NET	\$100.00-\$999.99	Less 15%
		\$500.00-\$999.99	Less 20%
\$25.00-\$99.99	Less 10%	\$10000.00 & up	Less 25%

Then Add the Standard Charge Below

STANDARD SHIPPING/HANDLING CHARGE

If your merchandise total after discount is between:

\$ 0.00 & 9.99	add \$2.00
10.00 & 49.99	add \$3.00
50.00 & 99.99	add \$4.00
100.00 & 499.99	add \$5.00
500.00 & 999.99	add \$6.00
1000.00 & 4999.99	add \$7.00
5000.00 & 9999.99	add \$8.00

Includes shipping and insurance to USA & Canada

**COD ORDERS ACCEPTED FOR SAME DAY SHIPMENT - ALL TEL 218-881-6674**

**SILICON TRANSISTORS**

MPS189	MPS190	MPS2222A	MPS2369A	MPS2712	MPS2907A	MPS3392
MPS3393	MPS3394	MPS3395	MPS3396	MPS3397	MPS3398	MPS3399
MPS3400	MPS3401	MPS3402	MPS3403	MPS3404	MPS3405	MPS3406
MPS3407	MPS3408	MPS3409	MPS3410	MPS3411	MPS3412	MPS3413
MPS3414	MPS3415	MPS3416	MPS3417	MPS3418	MPS3419	MPS3420
MPS3421	MPS3422	MPS3423	MPS3424	MPS3425	MPS3426	MPS3427
MPS3428	MPS3429	MPS3430				

# "HOT ONES" For 1977

## TOUCH TONE ENCODER KIT\*

# 1888



1.25M, 2-meter and 6-meter amateur radio operators if your rig is mobile, convert it easily to a mobile telephone station and contact your home, shop, school, factory TTY-100 touch tone encoder kit. Kit includes: Chromerics touch tone pad, Motorola MC14410 chip, trimpot, resistors, zener, diagram, and G-10 pc board. Electrical specs: 12-16 volts, 5 mA (max), 4 volts PP output. \* Less 1-MC crystal. **Cat. No. 1R3385**

Cat. No.	Description	Sale	BUY 'EM SEPARATELY
1R3149	Touch Tone Pad	\$4.50	
1R3382	MC14410 Chip	10.50	
1R3383	P.C. Board	2.95	

## DIGITAL CLOCK MODULE WITH BUILT-IN "CHIP"

# \$14.95

4-digit, 0.5" Digital Clock. LED, built-in red filter, with a MM5185 multi-function alarm chip, mounted on a 3 x 1 3/4" 1/4" module. Has all necessary discrete components mounted on module by factory to require only 8 function switches, brightness and voltage divider control, 12-16 volt filament transformer, AC line cord and case. Makes easy-built-in alarm and radio Alarm ON/OFF. Instruction and hookup diagrams. **Shpd. wt. 7 ozs.**

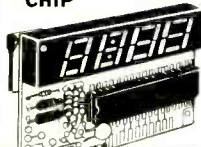

Cat. No. 1R3489

# 24.95

High Digits

8" - \$29.95  
Cat. No. 1R3423

## "BIG BING BEEPER" DIGITAL ALARM CLOCK KIT!

- 4 Jumbo LED digits!
- B-e-e-p-e-r alarm!
- Flashing seconds!
- Minimum of parts!

For home, room, office. All controls in front, makes visionary control easy. Features: 3 x 6 1/2" wide sloped woodtone/beige case. Uses famous all LED 0.6" high digits. Mostek 50250 "clock chip", with built-in beeper alarm circuitry. Front panel controls. ON-OFF ALARM, hour set, 10 minute set, hold, alarm set buttons. Flashing seconds colon, with speaker, audible beeper alarm. Includes backup power failure feature, 24-hour alarm, 115VAC 60 Hz power supply. **NOW IN KIT FORM. Wt. 3 lbs. Easy to build!**

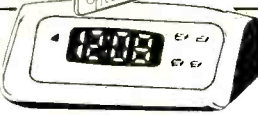

## CITIZENS BAND POWER SUPPLY

# \$19.95

- 12 VDC @ 3 AMPS
- REGULATED, CONTINUOUS DUTY
- CONVERTS CB, HAM RIGS TO HOME

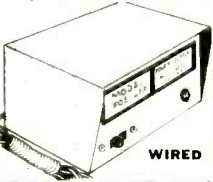

115V to 12VDC converter. Built-in automatic RESET circuit breaker. Powerful 3 amps (8 amps peak) makes it ideal for SSB rigs, too! Attractive walnut like metal modern-design cabinet (5 x 4 1/2 x 2 1/4"). Big U.S. maker design. Built-in circuit breaker. Front panel has OFF-ON switch and LED light. For 115 VAC 60 cycle. Wt. 8 lbs. **Cat. No. 1R3452**



## Rotron Fans

# \$8.88

- 115 VAC! Compact!
- Lightweight!
- Only 4-11/16" sq. x 1 1/2" deep!

Fans by Rotron. Used extensively for hi-fi eqpt because of low-cost, dependable cooling, as well as flushing computers, power supplies, office equipment, light projectors, transmitters, receivers & more! Weighs only 1-lb. **LOW NOISE LEVEL!** Humidity & moisture resistant motor. **REVERSIBLE AIR FLOW!** Impedance protected. Suitable for -40° to +140° F. Both 115 VAC, 3200 rpm, 15 watts, 1.5 amps. Hi-impact, flame retardant polycarbonate propellers in a reinforced phenolic venturi block. Removed from new equipment. Money back guaranteed. 1 1/2 lbs. **1R3108 "Muffin" 3-blade**

## MEMORIES!

8008 \$14.95

2102-1	\$1.95	8 FOR \$11.95
1702-A	\$9.95	3 FOR \$25.00
MM5262	\$1.95	3 FOR \$3.00

Terms: Add postage. Rated: net 30. **MIN. ORDER \$6**  
Phone: Wakefield, Mass. (617) 245-3829 (Plus Postage)  
Retail: 16-18 Del Carmine St., Wakefield.

## POLY PAKS

C.O.D.'s MAY BE PHONED

P.O. BOX 942R LYNNFIELD, MASS. 01940

## ADVERTISING INDEX

RADIO-ELECTRONICS does not assume any responsibility for errors that may appear in the index below.

### Free Information Number Page

65	Allison Automotive	82
49	American Audioport	Cover III
11	AP Products	79
79	B&K-Div. of Dynascan	25
59	Brooks Radio & TV	83
26	Chemtronics	85
	CIF-Cleveland Institute of Electronics	70-73
16	Channellock	28
12	Cobra-Div. of Dynascan	Cover IV
18	Continental Specialties	30
	CREI-Div. of McGraw-Hill Continuing Education	52-55
62	Dana Labs	84
15	Edmund Scientific	106
38	EICO	24
	E&I Instruments	76
13	Electronics Book Club	23
67	Electronic Control Technology	25
	EMC-Electronic Measurement	81
5	Fidelity Sound	24
71	GC Electronics	77
9	Grantham School of Electronics	85
	GTE Sylvania-Consumer Renewal	2
27	Handic of USA	27
100	Heath	17
53	Hickok Electrical Instruments	14
40	IMSAI Mfg.	22
14	Indiana Home Study Institute	78
68	International Crystal	84
58	JB Electronics	83
23	Jensen Tools & Alloys	26
28	Jerrold	5
	JS&A	Cover II
46	MITS-Micro Instrumentation Telemetry Systems	1
4	Mountain West Alarm Supply	79
10	National Camera Supply	79
	National Radio Institute (NRI)-Div. of McGraw-Hill Continuing Education Center	8-11
	National Technical Schools	18-21
20	PAIA Electronics	83
52	Perma Power	80
47	Pomona Electronics	16
54.55	Professional Aids	82
64	PTS Electronics	78
2	Radatron	77
	Radio Shack	15
48	SBE	7
33	Schober Organ	29
63	Southwest Technical Products	26
37	Tektronix	13
6.34	Telematic-Div. of UXL	29.81
7	Tri-Star	14

### MARKET CENTER

32	Active Electronics	103
	American Used Computer	86
44	Babylon Electronics	91
	Karel Barta	100
	CFR Associates	96
	Cornell Electronics	92
	Command Productions	96

### Free Information Number Page

31	Delta Electronics	102
	Devtronix Organ Products	96
51	Digi-Key	87
66	Fordham Radio Supply	102
19	Formula International	101
	Financial Management Associates	100
24	Godbout Electronics	92
	Information Unlimited	92
45	International Electronics	104
	Interfab	96
21.22	James	98.99
39	Jeff	92
	Lab Science	86
	Lakeside Industries	86
30	Meshna	96
57	Mini Micro Mart	96
29	New-Tone	94
8	Nexus Trading	102
42	Optoelectronics	105
1	Olson Electronics	86
	P.P.G. Electronics	100
41	Peninsula Marketing	100
25.35	Poly Paks	95.88
43	Quest	102
56	Radio Hut	93
	Science Workshop	86
70	SD Sales	97
36	Solid State Sales	94
3	Surplus Center	96
69	Tracy Design	92
	Trumbell	92
	Valley West	92
	Visulex	92

## MOVING?

Don't miss a single copy of **Radio-Electronics**. Give us:

Six weeks' notice

Your old address and zip code

Your new address and zip code

ATTACH LABEL HERE

name (please print)

address

city state zip code

Mall to: Radio-Electronics  
SUBSCRIPTION DEPT., P.O. BOX 2520,  
BOULDER, COLO. 80302



# Babylon-Pac super SALE! Each pac only \$1.98

All pac's are first quality (no fallout), tested and guaranteed.

<b>Linear pac</b> 8 assorted linears in mini-DIP or TO-5/741 oo amp, LM307 op amp, LM 703 RF-IF amp, with data and circuits \$1.98	<b>Flip-Flop pac</b> 10 assorted Flip-Flops, Dual JK's, RST's, and low power FF's, with data \$1.98	<b>Regulators</b> A LM723 DIP variable regulators, 2-40V, with data \$1.98
<b>Photocells</b> 10 Dual Cadmium Sulfide Photocells, by Clairex. \$1.98	<b>LED pac</b> 10 assorted discrete LED's-green, red, and infra-red, with data. \$1.98	<b>Comparator pac</b> 5 assorted DIP's--LM311, 710, 711, with data \$1.98
<b>Diodes</b> 100 Germanium computer signal diodes with leads trimmed for PCB mounting. \$1.98	<b>Linear pac</b> 8 assorted linears in mini-DIP or TO-5/741 oo amp, LM307 op amp, LM 703 RF-IF amp, with data and circuits \$1.98	<b>100 Resistors</b> 100 5% resistors of any single standard value from 2.7 ohm to 1M ohm. Not an ass't. \$1.98

Buy 5 pac's for \$9.90 and pic-a-pac for **10¢**

<b>739 pac</b> 5 Linears--dual low noise stereo amplifier 739. With data. \$1.98	<b>DIP RC Network</b> 50 assorted 14 and 16 pin IC packages containing precision resistors and capacitors--no data available \$1.98	<b>Transistor pac</b> 40 assorted TO-92 plastic transistors--PNP's and NPN's, mostly Fairchild house marked. \$1.98
<b>Silicon Diode pac</b> 40 Silicon Signal Diodes PRV better than 200V!! Leads trimmed for PCB mounting. \$1.98	<b>Capacitors</b> 20 25mfd 6V tantalum capacitors--5/16"x1/4" x1/8"--Long leads, PCB unmarked. \$1.98	<b>TIP31A Pac</b> 5 TIP31A NPN Power Transistor: HFE=100; IC-3A; VCEO=60V; 17W Power tab w/ formed leads \$1.98
<b>Trim pots.</b> 12 Miniature & subminiature PCB potentiometers, assorted values from 1K to 25K, by Pihler, Stackpole, etc. \$1.98	<b>UNTESTED PACS Transistors</b> 30 CMOS pac 40 assorted GE power ab series--NPN, PNP and the Darlingtons. Untested connections supplied. \$1.98	
<b>TTL 270</b> 25 Quad 2 input NAND gates, pin compatible with SN7400. Current drain 1/2 of 7400 and speed is less. New units branded Signetic and marked 270". \$1.98	<b>Axial Rectifiers</b> 30 Axial Rectifiers, untested. 1 Amp--1200V. Cosmetic rejects due to poor plating. \$1.98	<b>IC Assortment</b> 100 Untested ICs, 11 DIP, mostly TTL--some marked, housemarked or unmarked. \$1.98

### LINEARS

NE555	PRECISION TIMER MINI DIP	\$ 2.70
NE560	PHASE LOCK LOOP DIP	2.95
NE565	PHASE LOCK LOOP DIP	2.95
5558	DUAL 741 OP AMP MINI DIP	1.00
709	POPULAR OP AMP TO-5	.30
710	VOLTAGE COMPARTOR DIP	.30
711	DUAL VOLTAGE COMP. DIP	.24
739	STEREO AMPLIFIER DIP	.50
741	OP AMP MINI DIP TO-5	.35
748	OP AMP TO-5	.80
HA2500	HARRIS OP AMP TO-5	.80
LM300	POSITIV DC REGULATOR TO-5	.75
LM301	HI PERF. AMPL. MINI-DIP	.50
LM302	VOLTAGE FOLLOWER TO-5	1.25
LM305	PRECISION VOLT. REGULATOR TO-5	1.00
LM307	OP AMP TO-5 - MINI-DIP	.35
LM308A	PRECISION OP AMP TO-5	1.00
LM311	VOLTAGE COMPARTOR MINI-DIP	1.25
LM370	AGE AUDIO AMP DIP TO-5	1.75
LM380	2 WATT AUDIO AMP DIP	1.35
LM381	LOW NOISE STEREO AMP DIP	1.75
LM301	INSTANTBLT MULTIVIBRATOR NPN	.55
LM302	DUAL 9001	.95
MC1536	HI VOLTAGE OP AMP TO-5	1.35
CA3018	2 TRANSISTORS AND A DARLINGTON CONNECTED PAIR TO-5	1.00
CA3026	TRANSISTOR ARRAY w/ 2 INDEPENDENT DIFFERENTIAL AMPLIFIERS	1.00
CA3030	17W NOISE DUAL DARL. ARRAY	1.00
CA3081	7 NPN TRANSISTORS WITH COMMON EMITTER CONF. DIP	1.00
73491	QUART SEGMENT DRIVER	1.00
73492	KEY DIGIT DRIVER	1.00

### POTTER BRUMFIELD

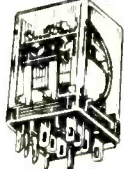

Type KHP Relay  
4 PDT 3A Contacts  
24V DC . \$1.50 (650 coil)  
120V AC. \$1.75 (10.5 MA coil)

### CD-2 COUNTER KIT



This kit provides a highly sophisticated display section module for clocks, counters, or other numerical displays. Unit is .8" x 4 3/8", and requires a 5V power source. Kit includes 2-sided PC board with plated-through holes, 7490, 7475, 7447, RCA DR2010, complete instructions, and Molex. When ordering please specify single digits or panels of up to 10 digits (with all interconnects.)

COMPLETE KIT \$7.95 per digit

### CD-3 COUNTER KIT

This kit can be programmed to count to any modulus: 2-9 for one kit, 2-99 for two kits, etc. Includes all as in CD-2, 2 resistors, 3 diodes, but without the 7475 quad latch. Perfect for displays of seconds, minutes, hours, etc. Full instructions included.

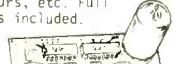

When ordering please specify single digits or panels of up to 10 digits (with all interconnects.)

COMPLETE KIT \$6.25 per digit

### TRIACs



RCA 8 amp 500+ volt triacs, house numbered.

**59¢ each**

### 3 Amp Power Silicon Rectifiers

MARKED AXIAL PACKAGE

PRV	EACH	PRV	EACH
50	\$ 0.08	600	\$ 2.24
100	.13	700	.27
200	.15	800	.30
300	.18	900	.40
400	.20	1000	.50
500	.22	1200	.60
		1400	\$ 7.70

### 25K Trimmer



Printed Circuit Board Type  
Each \$ 2.20  
10 for \$1.50

### PCB IC Sockets

8 pin	.19
14 pin	.19
16 pin	.21
24 pin	.55
28 pin	.70
40 pin	1.10

14 pin wire wrap sockets gold inlay, long leads. Texas Instruments.

### MOLEX

500	\$ 4.50
1000	8.00
2000	15.00
5000	35.00
10000	70.00
25000	150.00

### Capacitors

PCB vertical mount tantalum capacitors--shown is actual size

Values--4.7mfd 16V; 6.8mfd 6V; 10mfd 25V; 33mfd 10V.

**25¢ each**

### RCA Numitron DR2010



EACH \$ 5.00  
5 for 20.00  
10 for 37.50

### Data Keyboards

63 black keys, no encoder. High quality SPST switches--13" x 4" sturdy plastic base.

**\$19.95**

### 7400dip

7400	.16	74L72	.60
74400	.18	7475	.25
7401	.16	74L73	.75
7402	.21	7474	.30
7404	.18	74L74	.75
74H04	.30	7475	.50
7405	.24	7476	.30
7406	.25	74L78	.70
7408	.25	748C	.50
74H08	.30	7483	.50
7410	.18	749C	.50
74H10	.30	7492	.35
7413	.45	7493	.55
7417	.35	7495	.65
7420	.16	74L95	1.00
74L20	.25	74L07	.25
74H20	.18	74L10	1.00
74H22	.30	74L23	.75
7426	.29	74L25	1.00
7430	.16	74L45	1.10
74H30	.30	74L54	1.00
74L30	.30	74L55	.90
7440	.15	74L57	.90
7441	.89	74L63	.90
7442	.50	74L64	1.20
7447	.80	74L65	1.00
7448	.80	74L66	1.40
7450	.16	74L74	1.00
74H50	.30	74L77	.80
7451	.16	74L79	1.00
74H51	.25	74L80	1.00
7453	.16	74L92	.90
74L54	.25	74L93	1.00
74L55	.25	74L97	.80
7460	.16	75491	1.00
74L71	.20	75492	1.00
7472	.40		

### CMOS

CD4001	.29	CD4029	2.25
CD4002	.29	CD4030	.65
CD4009	.59	CD4042	1.50
CD4010	.55	74C20	.65
CD4011	.29	74C42	2.00
CD4012	.29	74C160	2.50
CD4013	.69	74C19	2.25
CD4015	1.90	74C74	1.00
CD4016	.69	74C153	2.50
CD4019	.69		

### NATIONAL MOS TO-5

STATIC SHIFT REGISTER

MM504	dual 16 bit	\$1.50
MM505	dual 32 bit	1.75
MM550	dual differential analog switch	2.50

DYNAMIC SHIFT REGISTER

MM502	dual 50 bit	\$1.25
MM506	dual 100 bit	1.75
MM5006	dual 100 bit	1.50
MM5013	1024 bit	2.25

### FULL WAVE BRIDGE RECTIFIERS



25A - 500 PIV \$2.50 ea. 10/\$20.00  
25A - 100 PIV \$1.50 ea. 10/\$12.50

### DIP TRIMMER



-12 turn trim pots which plug into a DIP socket  
-5K and 200K  
-1/2" x 1/2" x 1/2"  
-4 leads spaced .3" x .2"  
Each \$ .65 10 for \$4.95

### SPACE AGE CLOCK KIT



Instructions & parts - 12 or 24 hour format.  
Four digit clock kit includes all parts for complete clock: 3 1/2" x 2 1/2"  
-FN0 70 readouts  
-M5314 clock chip & all transistors, etc.  
-extruded aluminum case  
-cord with transformer plug

**\$16.95**

### 12V DC Relay



DPDT - 1A Contacts  
Prime - 500 ohm coil  
PCB - rated 12V, but works well at 6V.  
Dimensions: 1 1/16" x 1 3/16" x 1 5/16"  
Each \$1.35 Ten for \$12.50

### KEYBOARD ASSEMBLY

TRW Data Systems unit; 10 keys 0-9; 3 (or 4) 24V lamps; printed circuit board w/14 IN4001 diodes, capacitors, transistor, and resistors. All mounted in an attractive case approx. 4 1/2" x 4 1/2" x 2 1/2". These are used; no schematic is available. EACH \$6.95

### TRANSISTORS

2N4248-HEP715, PNP, 40V	Each 15c 10/\$1.00
2N2222-NPN, 1.8W, 40V	Each 20c 10/\$1.75
2N5964-HEP50005, NPN 150V	Each 15c 10/\$1.00
2N4400-NPN, 40V.	Each 15c 10/\$1.35

### AP Super Strip

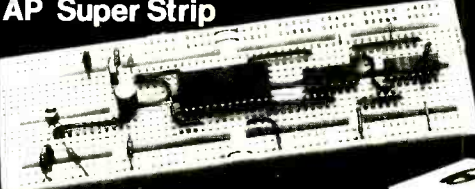

**\$13.00**

AP 14 pin test clip.	\$3.50
16 pin test clip.	3.80
24 pin test clip.	12.00

MONEY BACK GUARANTEE ON ALL GOODS! Phone (916)334-2161

Orders under \$7.00 add \$1.00 postage and handling. Residents of Cal. add sales tax. Orders shipped promptly. \$10 minimum on C.O.D.s.

4811 Myrtle Ave. Sacramento, CA

Mail orders to: P.O. Box 41778 Sacramento, CA 95841

Send a stamp for our flyer listing more money-saving bargains!

**BABYLON ELECTRONICS**

Your BANKAMERICARD welcome here

**NEW**

wafers are meant to be inserted in a .063" maximum thickness board and have .043" diameter pins on .156" centers.

CATALOG NUMBER	DESCRIPTION	PRICES	
		1-10	11-99
13-0001	12 pos. rt. angle connector	60	.50
13-0002	12 position wafer	60	.50
13-0003	9 pos. rt. angle connector	60	.50

**SPECIAL!**  
1000 Molex IC terminals for \$7.50  
2000 for \$13.50

**SPECIAL!**  
Motorola 741 Mini Dip  
35¢-10 for \$3.00

**ELECTROLYTIC CAPACITORS**

PLEASE ORDER IN MULTIPLES OF 5 PER ITEM

RADIAL LEAD	WORKING VOLTS DC	VALUE (uF)	PRICE
10	16, 35, 50	.16	.25
20	16, 35, 50	.16	.25
30	16	.16	.25
50	16, 35	.22	.25
100	16, 35, 50	.25	.25
200	16	.25	.25
500	16	.34	.25
1000	16	.52	.25
2200	16	.80	.25

NE501A 2.80  
NE555A .50  
A710CA .60  
A741V .40  
A747CA 1.10  
A748CV .74  
A723CA 1.00  
MC1468L 3.90

**LINEAR**

Red Led & Mtg. Hardware  
T1-3/4  
1-10 11-100  
.35 .29

**MINIATURE FILM CAPACITORS**

VALUE (uF)	1-14	15-50	51-100
.001	.10	.10	.06
.0047	.10	.10	.06
.01	.10	.10	.06
.05	.19	.17	.15
.1	.20	.18	.16
.22	.25	.23	.21

These units are made by International Components Corp. All units 100V

**FIXED POWER SUPPLY KITS**

Model	P0510	F1210	F1610
Input Voltage (50 500Hz)	105 125v	105 125v	110 125v
Output Voltage	5v ± 5%	12v ± 5%	15v ± 5%
Output Current (T., + 25°C)	1.5A Max.	1.5A Max.	1.1A Max.
PRICE	\$14.00	\$14.50	\$14.50

INDEFINITE SHORT CIRCUIT PROTECTION Price includes Pre drilled G 10 Board, All Parts and Transformer

**DISPLAY BEZELS**

CATALOG NUMBER	FILTER COLOR	PRICE	DIMENSION
905-60	Red	\$2.75	1 3/8" x 2 1/8"
910-60	Red	2.80	2.00" x 2.00"
915-60	Red	2.90	3.00" x 4.00"
920-60	Red	2.90	4.00" x 4.00"
920-70	Amber	2.95	4.00" x 4.00"

These bezels are made of clear plastic with a black matte finish. Filters are circular polarized type

**SOCKETS**

These sockets are from TI.

NUMBER OF PINS	500	1000
14	.21	.18
16	.25	.24
24	.40	.33
28	.50	.48

**TRANSISTORS**

2N3638A	P	5	TO-92	.25
2N2222A	N	5	TO-18	.20
2N5133	N	05	TO-18	.25
2N5494	N	7	TO-220	1.05
2N4401	N	60	TO-92	.60
2N4403	P	60	TO-92	.30
TIP32	P	3.00	TO-220	1.05

**TRIMMER POTENTIOMETERS**

These are 5/8" diameter thumbwheel trimmer potentiometers

VALUES OHMS  
100 500 1K 5K 10K 20K  
25K 250K 50K 100K  
1M 5M

PRICE TABLE	110	11-99	100
	.30	.29	.27

TERMS \$10.00 Min. Order.  
Orders less than \$25.00 add \$1.00 postage & handling  
Master charge & Bank Americard

**BAG OF 50 MOLEX PIN NESTERS**

7 pin style \$2.00  
# pin \$2.25

**MOLEX IC TERMINAL**

100 for \$1.00	300 for \$2.80	500 for \$4.20
200 for \$1.80	400 for \$3.40	800 for \$5.00
700 for \$5.80	800 for \$6.80	900 for \$7.40
1000 for \$8.20		

Reel of 50,000 ..... \$ 279.00

**REGULATOR CIRCUITS**

MC7805CP	5 volt regulator @ 1.5A max.	1.99
MC7812CP	12 volt regulator @ 1.5A max.	2.00
MC7815CP	15 volt regulator @ 1.5A max.	2.00

**16 Page Catalog 25¢**

**DIODES**

1N4001	10/\$1.00
1N4002	10/\$1.00
1N4148	10/\$1.00
1N5401	5/\$2.00
(SA 100P1V)	

1N746-739A \$ 3.30

**TRACY DESIGN CORP.**  
15870 SCHAEFER • DETROIT, MI 48227 • (313) 838-2501

**GODBOUT**

BILL GODBOUT ELECTRONICS  
BOX 2355, OAKLAND AIRPORT, CA 94614

\$4.95	A 3.5W	1.0W	310mW	30%	sim RCA 2N5470
\$5.95	B 8.7W	2.5W	300mW	33%	sim RCA TB407
\$6.95	B 21W	5.5W	1.25W	33%	sim RCA 2N6269
\$7.95	B 29W	7.5W	1.5W	33%	factory select part--2N6269

PRICE FIG. PD MAX @ 250C POIT MIN @ 2 GHz PIN EFFICIENCY @ 2.0 GHz

**RF POWER TRANSISTORS**

**709 OF AMP 4/\$1**

MultiMeter **\$14.99**

- \*6 DC Volt ranges
- \*3 DC current
- \*5 AC RMS ranges
- \*2 ohms ranges
- \*-20 to +22 dB
- \*Includes 34" test leads
- \*20KΩ/V DC
- \*10KΩ/V AC
- \*50 uA meter
- \*Ohms adjust
- \*5/4" x 3/4" x 1 5/8"

REQUIRES 1 AA CELL (not incl.) ADD \$1 POST/HANDLING

**3pst Dipswitch \$1.95**

**Special! 1 Meg Trimpot 6 for \$1**

**SEND FOR OUR FLYER**

TERMS add 50¢ to orders under \$10. NO COD. Cal res add tax. Mastercharge\*/BankAmericard\* call (415) 562-0636, 24 hours. SEND FOR OUR FLYER!

**CIRCLE 24 ON FREE INFORMATION CARD**

**Hand Held Digital STOPWATCH**

This device is accurate to .001% or better. It's only 4.5"x2.5"x1.25"; and weighs only 7 oz. 6-digit display indicates minutes, to 59; seconds, to 59; and .01 seconds, to 99. Nickel Cadmium batteries and charger are included at no extra charge! Kit includes all parts, case, P.C. boards, and instructions.

**Assembled \$64.95 KIT \$49.95**

**4-DIGIT ALARM CLOCK**

Kit includes xformer, P.C. boards & all components. It has huge 1/2" red L.E.D. displays. It also has a 24 hour alarm format with a 9-min. snooze.

**Only 10.99 Case 3.99**

**6-DIGIT 12-24 Hr. CLOCK**

Available in 1/4" or 1/2" red L.E.D. Displays. Kit includes all components, xformer, and P.C. Boards.

**1/2" DIGITS \$15.99 3/4" DIGITS \$12.99**  
**CASE 4.99 CASE 3.99**

**ALARM CALENDAR CLOCK**

It lights up the time for 8 seconds then gives the date in month and day of month. Has a 12 or 24 hour format, 24 hour alarm with 10 minute snooze, and is available in 1/4" or 1/2" red L.E.D. displays. Kit includes all components, xformer, and P.C. Boards.

**1/2" DIGITS \$25.99 3/4" DIGITS \$21.99**  
**CASE 4.99 CASE 3.99**

**NE555 10/3.99 7447.69 3/1.99**

**14 Pin IC Sockets—.18-10/1.59**  
**40 Pin IC Sockets—.39-5/1.79**

**Red jumbo LED 10/1.00**

**TERMS:** Ohio residents add 5 1/2% sales tax. Add 5% of total amount for P&H but a minimum of \$1.00.  
**Send SASE for catalogue now!**

**JEFF 3015 Eaton Road, Cleveland, OH. 44122**

**PRINTED CIRCUIT**

Positive Acting Photo Resist; Carbide bits; Bubble etchers; Artwork; Epoxy Glass Boards.

**Send stamp & address label for flyer**

**TRUMBULL**  
833 Balra Dr., El Cerrito, CA 94530

**NEW adjustable three-output regulated power supply**, plus 900 parts worth \$400.00 list, contained in a solid-state Cartrivision television recorder electronic unit. Schematics, parts cross-reference furnished. Uses: Heathkit television transistor substitutions, power CB radios and microprocessors, build electronic projects. \$17.95 plus \$3.50 S&H, USA. Free brochure. Master Charge, BankAmericard. Satisfaction guaranteed. **MADISON ELECTRONICS COMPANY, INCORPORATED**, Box 369, D101, Madison, AL 35758

**PARTS! CORNELL TUBES!**

Send For FREE CORNELL'S New Color Catalog 48 Pgs. New Items IN LOTS OF 100 4215 E. UNIVERSITY AVE. SAN DIEGO, CALIF. 92105

**33¢ per Tube** **36¢ per Tube**

ORDER FREE IF NOT SHIPPED IN 24 HOURS

**SURPRISES galore!** Projects, ham radio, music synthesizers, etc. IC's, pots, hardware, crystals, keyboards, resistors, etc. Send 13¢ stamp for catalogue. **UTEP**, Box 26231C, Salt Lake City, UT 84125

**BACK issue magazines.** Over 200 titles, 1890 to 1976. Send stamped envelope. Free list. **EVERYBODY'S BOOKSHOP**, Dept. RE, 317 West 6th, Los Angeles, CA 90014

**AMAZING ELECTRONIC PROJECTS and PRODUCTS:**

Lasers Super Powered, Burning, Cutting, Rifle, Pistol, Pocket. See in Dark—Shotgun Directional Mike—Unscramblers—Giant Tesla—Stunwand—TV Disrupter—Energy Producing, Surveillance, Detection, Electrifying, Ultrasonic, CB, Auto and Mech. Devices, Hundreds More—All New Plus INFO UNLTD PARTS SERVICE, Catalog \$1. Information Unlimited, Box 626, Lord Jeffery Court, Amherst, N.H. 03031.

**PLANS & KITS**

**SAVE 50%.** Build your own speaker systems. Write: **MCGEE RADIO ELECTRONICS**, 1901 McGee Street, Kansas City, MO 64108

**ELECTRONICS DESIGN NEWSLETTER**

- ★ Logic Design Techniques
- ★ Digital & Linear Design Theory & Procedures
- ★ Construction Projects

Learn Design Techniques! Write for FREE CATALOG of parts & kits

Subscription \$6 Sample Copy \$1

**VALLEY WEST** Box 2119-L Sunnyvale, CA 94087

**ORGANS—PA Systems**, electronic pianos—string synthesizers—speakers—guitar amplifiers—electronic sound rotators. Modern integrated circuitry. Factory assembled or easy-to-build custom kits. Send one dollar (refunded with first purchase) to **WERSI ELECTRONICS**, Dept. A, Box 5318, Lancaster, PA 17601

**TV games kits P/C boards**

**Send for your information packet today—** which also includes circuit functions, component line-up, and accessories. Information Packet \$1.00 (refundable with order)

**visulex** P. O. Box 4204R Mountain View, CA 94040



# Radio Hut



P. O. BOX 64783  
DALLAS, TEXAS 75206



CALL OUR TOLL FREE NUMBER  
1-800-527-2304

TERMS: NO COD's. Check or money orders only. Texas Residents add 5% State Sales Tax. Add 10% of total order for postage and handling. Overseas orders add 20% for P&H. Foreign orders - US Funds ONLY! Phone orders welcome! - in Dallas call 214/271-8423.

## READOUTS

<p><b>FND 800</b> Common Cathode Large .80" character Low current drain! \$2.95 each</p>	<p><b>FND 359</b> Common Cathode Direct Replacement For FND 70 but larger .40" character .95 each or 10 for \$8.79</p>
--	--

**FCS 8000**  
Common Cathode  
12 hour - 3 1/2 digit array  
Includes AM/PM Indicator & Colons  
.80" character  
\$6.25 each

**FCM 7010**  
4 Digit Direct Drive Radio Alarm Clock Chip  
Similar to MK5038C \$6.25 each

## FULL WAVE BRIDGES

25 amp - 50 volt - \$1.65 each  
4 amp - 50 volt - \$1.50 each  
1 amp - 50 volt - .99 each

Motor for home tape decks. Operates on 115 Vac 60 HZ. Shielded construction; High torque capability; and is four pole type.

LIMITED QUANTITY!  
\$2.70 each

**DIODES by MOTOROLA**  
2 1/2 amp - 1000 volt  
6 for \$1.00

## CMOS

100% GUARANTEED!

100% PRIME!

CD4001 .23	CD4017 1.00	CD4030 .40	CD4056 1.80
CD4002 .23	CD4018 1.20	CD4035 1.24	CD4060 1.45
CD4007 .23	CD4019 .40	CD4040 1.35	CD4066 .85
CD4009 .53	CD4021 1.20	CD4041 .85	CD4071 .23
CD4010 .49	CD4022 .95	CD4043 .73	CD4076 1.25
CD4011 .23	CD4023 .23	CD4044 .50	CD4098 1.65
CD4012 .23	CD4024 .87	CD4049 .55	CD4512 1.30
CD4013 .45	CD4025 .23	CD4050 .50	CD4516 1.75
CD4014 1.30	CD4027 .53	CD4051 1.45	CD4518 1.60
CD4015 1.10	CD4028 .90	CD4052 1.25	CD4520 1.60
CD4016 .49	CD4029 1.20	CD4053 2.25	CD4911 .30

SPECIAL!

A 12 HOUR BASIC CLOCK KIT  
Display with case includes:  
\*FCS 8000 3 1/2 Digits  
.80" character

\*M7010 Direct Drive Clock Chip

\*Sloped Front Case - Punched for Display

\$11.25 each

## ALUMINUM PROJECT CASES

(Order by Number)

**CASE 1**  
H - 1 1/2" \$2.50  
W - 3" \$2.50  
L - 4 3/8"



**CASE 2** \$3.40  
H - 2" \$3.40  
W - 4 7/8" \$3.40  
L - 3 1/2" \$3.40  
Slope Front - 3/4"

**CASE 3**  
H - 2 1/2" \$3.00  
W - 7" \$3.00  
L - 4" \$3.00  
Slope Front - 1/2"

**CASE 5**  
H - 1 1/2" \$1.50  
W - 2 7/8" \$1.50  
L - 2 3/4" 99c each



**CASE 4**  
H - 1 7/8" \$1.50  
W - 4 3/8" \$1.50  
L - 3" \$1.50

## VOLTAGE REGULATORS

LM 340-6 .99	LM 340-15 .99
LM 340-8 .99	LM 340-18 .99
LM 340-12 .99	LM 340-24 .99

A GOOD BUY!

1/2 LB. OF SCREWS, NUTS & WASHERS

All Hardware is New!  
Includes 2-56, 4-40, 6-32 and 8-32  
1/2 pound - \$1.75  
or  
1 lb. for \$3.00

7400 .19	7438 .39	<b>TTL</b>	1	74148
7401 .19	7440 .19		0	1.35
7402 .19	7442 .65	0	74153 75	
7403 .19	7443 .65	%	74163	
7404 .19	7444 .69		1.10	
7405 .19	7446 .89	G	74164	
7406 .29	7447 .85	U	1.10	
7408 .19	7450 .24	A	74174 .95	
7409 .19	7451 .19	R	74175	
7410 .19	7453 .19	A	1.80	
7411 .29	7454 .19	A	74191	
7413 .50	7470 .38	N	1.25	
7420 .19	7472 .25	T	74192	
7421 .19	7473 .25	E	1.25	
7423 .39	7474 .39	E	74193	
7425 .30	7475 .59	D	1.00	
7426 .27	7476 .35		74194	
7427 .19	7483 .95		1.20	
7437 .39	7485 .95		74195 .69	





# Poly Pak's EXCLUSIVE Avg. Ship. \$1.98 Wt. 6 ozs.



Every kit carries a money back guarantee!

YOUR CHOICE OF ANY KIT

Buy 10 BARREL KITS AND CHOOSE THE 11TH Free

**100'S OF BARRELS PURCHASED!**  
For the first time anywhere, Poly Pak merchandisers introduce a new way in buying the economical way. Raw stock from the "barrel". Remember the "good old days"? They're back again. The same way merchandisers

throughout the United States buy from various factories... their overruns in barrels. Poly Pak has done the same. Therefore you are getting the same type of material as the RE-TESTERS DO!  
**TEST 'EM YOURSELF 'N SAVE!**

**BARREL KIT #205 MINI BLOCK CAPACITORS 100 for \$1.98**  
Unbelievable! Worth \$50. High precision submini caps for all applications. Wt. 3 ozs. Cat. 1R3528

**BARREL KIT #201 6V INDICATORS w/leads 15 for \$1.98**  
Test lamp manufacturer dumps inventory! Worth 60¢ ea. Like grain-o-wheat. Cat. No. 1R3526

**BARREL KIT #195 CARBO-FILM RESISTORS 75 for \$1.98**  
Hard to find; but we got millions. Lo & Hi values. 1/2 and 3/4 watt, 5% to 10% tol. All marked. Cat. No. 1R3534

**BARREL KIT #203 CALCULATOR KEYBOARD \$10 for \$1.98**  
It's true! 20 key 4 function keyboard at ridiculous give-away. 12 ozs. Cat. No. 1R3534

**BARREL KIT #200 6 DIGIT READOUT MODULES \$5 for \$1.98**  
Calculator & driver chips. 12 ozs. epoxy. Cat. No. 1R3534

**BARREL KIT #198 400 PAIR 1.98**  
Includes resistors, caps, transformers, rectifiers, diodes, etc. for work. 100% material. 100% yield. Barrel by factory. 100% good. Cat. No. 1R3534

<b>BARREL KIT #186 KEYBOARD CHIPS 10 for \$1.98</b> Truthfully we can't seem to sell MM5740's. Keyboard encoder chips. How good they are we don't know. Cat. No. 1R3414	<b>BARREL KIT #184 1/4-WATT METAL FILM 150 for \$1.98</b> 100% metal film resistors. Long leads. 1R3413	<b>BARREL KIT #182 JUMBO RED LEADS 15 for \$1.98</b> 100% material, super cancellation from factory dumps. 3V 10 mils. For 100% of projects, red lens. Cat. No. 1R3369	<b>BARREL KIT #183 MINI TRIM POTS 30 for \$1.98</b> Ass't. values 100 to 1 meg. 2N5906's of 100% material. TO-92. Preformed. Cat. No. 1R3345	<b>BARREL KIT #161 POP! PLASTIC TRANSISTORS 25 for \$1.98</b> 2N5904's with some 2N5906's of 100% material. TO-92. Preformed. Cat. No. 1R3343 1 oz.	<b>BARREL KIT #160 V. REGULATORS 15 for \$1.98</b> LM309KC TO-3 V.R.'s barreled. Bot by the pound. No. 1R3330	<b>BARREL KIT #159 MODULAR SWITCHES 25 for \$1.98</b> Centralab switches. TV-makers excel. Dnt. 3p. etc. Brand new. Cat. No. 1R3327	<b>BARREL KIT #143 75-PC TRANSISTORS \$1.98</b> 100% material, TO-92, factory discontinued lines, pnp's mixed with npn's. 2N1400-12-25-34. 1R3290	<b>BARREL KIT #141 10 WATT ZENERS 15 for \$1.98</b> 4 ozs. Mfr dumps to spare for new styles. Takes all over the place. Good yield. Cat. No. 1R3286	<b>BARREL KIT #127 AXIAL ELECTROS 40 for \$1.98</b> Ass't. capacities and voltages. Cat. No. 1R3227	<b>BARREL KIT #126 UPRIGHT ELECTROS 40 for \$1.98</b> 1mf to 300mf in mixture of voltages. 100% marked in good. 1R3226	<b>BARREL KIT #119 PRECISION RESISTORS 100 for \$1.98</b> PREFERRED! Designed for precision work. 1/2 & 3/4 watt. 1% to 5% tol. Marked. Cat. No. 1R3205	<b>BARREL KIT #118 MINI SCRS 50 for \$1.98</b> UNBELIEVABLE! TO-92 plastic SCRS in barrels... all voltages up thru 200 v. 1R3135	<b>BARREL KIT #117 200-FT. OPTICAL FIBERS 30 for \$1.98</b> Fiber optic factory bankruptcy purchase! High quality. Most commonly used size (20-mil). CLEAR. Cat. No. 1R3255	<b>BARREL KIT #116 BUTTONS 'N FEEDTHRU'S 100 for \$1.98</b> Wide asst. of button-feedthru caps! HAMS TAKE NOTE! RFI, UHF, etc. Wt. 1 lb. Cat. No. 1R3141	<b>BARREL KIT #115 MOLEX SOCKETS 200 for \$1.98</b> Calculator maker dump! We got a zillion of 'em. Used for IC sockets. Cat. No. 1R3144	<b>BARREL KIT #112 MICRO MINI LEADS 40 for \$1.98</b> All the tiny leads, axial, upright of Monsanto, Litronix, variety of colors. Yield 60% or better. 1R3135	<b>BARREL KIT #92 3 AMP EPOXY RECTIFIERS 100 for \$1.98</b> Cosmetic rejects, electrically fine business! You check 'em, it's not for us. Ass't. voltages. 1R3204	<b>BARREL KIT #88 LITRONICS LED READOUTS 10 for \$1.98</b> 15's, 22's, singles, red, blue, etc. 100% good. From factory. All mixed. Have fun! 1R2861	<b>BARREL KIT #87 NATIONAL IC BONANZA 100 for \$1.98</b> Types: 7400, 7410, 7412, 7413, 7414, 7415, 7416, 7417, 7418, 7419, 7420, 7421, 7422, 7423, 7424, 7425, 7426, 7427, 7428, 7429, 7430, 7431, 7432, 7433, 7434, 7435, 7436, 7437, 7438, 7439, 7440, 7441, 7442, 7443, 7444, 7445, 7446, 7447, 7448, 7449, 7450, 7451, 7452, 7453, 7454, 7455, 7456, 7457, 7458, 7459, 7460, 7461, 7462, 7463, 7464, 7465, 7466, 7467, 7468, 7469, 7470, 7471, 7472, 7473, 7474, 7475, 7476, 7477, 7478, 7479, 7480, 7481, 7482, 7483, 7484, 7485, 7486, 7487, 7488, 7489, 7490, 7491, 7492, 7493, 7494, 7495, 7496, 7497, 7498, 7499, 7500. Cat. No. 1R2738	<b>BARREL KIT #86 HOBBY LEADS 40 for \$1.98</b> Went to Litronics dump of all kinds of mixed diodes, LEDs, shapes, colors, good, mon. etc. 1R2859	<b>BARREL KIT #81 SUBMINI RESISTORS 200 for \$1.98</b> PC upright type, color coded. 1/2 watt. Ass't. values. Come out in a barrel. Cat. No. 1R2746 100% good.	<b>BARREL KIT #80 PHOTO ELECTRIC CELLS 10 for \$1.98</b> Ass't. GE types, CDS types. Mixed by factory. Big job for us to separate. 100% good. Cat. No. 1R3052	<b>BARREL KIT #79 MIXED READOUTS 100 for \$1.98</b> Factory returns - such numbers as MAN-4's, MAN-7's, MAN-8's, 11 barrels & no time for separate. Cat. No. 1R2733 Untested.	<b>BARREL KIT #78 741 MINI DIP "BONANZA" 50 for \$1.98</b> Barrels in barrels of this. This is a buyer's market. How many can we get tested. Cat. No. 1R2626	<b>BARREL KIT #77 200-FT. OPTICAL FIBERS 30 for \$1.98</b> Hi-Fi mfr's shelf inventory but it dumped 'em in barrels. Preformed for PC use. Mixed values too! 1R2605	<b>BARREL KIT #76 1-WATT ZENERS 100 for \$1.98</b> Factory same as \$100-mw's. Never lose again offer. 6.8, 8.2, 10, 15V, under glass. Double pig. Cat. No. 1R2741 Untested.	<b>BARREL KIT #75 CAPACITOR SPECIAL 100 pcs. \$1.98</b> mixed, moul'd, plastics, ceramics, discs, etc. 100% good. Cat. No. 1R2738	<b>BARREL KIT #74 MIXED IC'S 100 for \$1.98</b> All shapes, 7400 Series, 8000, 9000, ROMS, RTL's, DTL's, linear of all kinds. Cat. No. 1R2730	<b>BARREL KIT #73 TRANSISTOR ELECTROS 50 for \$1.98</b> We don't wish to separate wide asst. voltages & values up to 300 mV. 1R2747	<b>BARREL KIT #72 741 MINI DIP "BONANZA" 50 for \$1.98</b> Bargain of a lifetime! All we got was 1 barrel - All the "blister digit" types. Multiple. Cat. No. 1R2722	<b>BARREL KIT #71 CAPACITOR SPECIAL 100 pcs. \$1.98</b> mixed, moul'd, plastics, ceramics, discs, etc. 100% good. Cat. No. 1R2738	<b>BARREL KIT #70 741 MINI DIP "BONANZA" 50 for \$1.98</b> Bargain of a lifetime! All we got was 1 barrel - All the "blister digit" types. Multiple. Cat. No. 1R2722	<b>BARREL KIT #69 741 MINI DIP "BONANZA" 50 for \$1.98</b> Bargain of a lifetime! All we got was 1 barrel - All the "blister digit" types. Multiple. Cat. No. 1R2722	<b>BARREL KIT #68 2 WATTS 100 for \$1.98</b> 100% good. Cat. No. 1R2735	<b>BARREL KIT #67 NATIONAL IC BONANZA 100 for \$1.98</b> Types: 7400, 7410, 7412, 7413, 7414, 7415, 7416, 7417, 7418, 7419, 7420, 7421, 7422, 7423, 7424, 7425, 7426, 7427, 7428, 7429, 7430, 7431, 7432, 7433, 7434, 7435, 7436, 7437, 7438, 7439, 7440, 7441, 7442, 7443, 7444, 7445, 7446, 7447, 7448, 7449, 7450, 7451, 7452, 7453, 7454, 7455, 7456, 7457, 7458, 7459, 7460, 7461, 7462, 7463, 7464, 7465, 7466, 7467, 7468, 7469, 7470, 7471, 7472, 7473, 7474, 7475, 7476, 7477, 7478, 7479, 7480, 7481, 7482, 7483, 7484, 7485, 7486, 7487, 7488, 7489, 7490, 7491, 7492, 7493, 7494, 7495, 7496, 7497, 7498, 7499, 7500. Cat. No. 1R2738	<b>BARREL KIT #66 MIXED IC'S 100 for \$1.98</b> All shapes, 7400 Series, 8000, 9000, ROMS, RTL's, DTL's, linear of all kinds. Cat. No. 1R2730	<b>BARREL KIT #65 MIXED READOUTS 100 for \$1.98</b> Factory returns - such numbers as MAN-4's, MAN-7's, MAN-8's, 11 barrels & no time for separate. Cat. No. 1R2733 Untested.	<b>BARREL KIT #64 741 MINI DIP "BONANZA" 50 for \$1.98</b> Bargain of a lifetime! All we got was 1 barrel - All the "blister digit" types. Multiple. Cat. No. 1R2722	<b>BARREL KIT #63 METAL CAN TRANSISTORS 100 for \$1.98</b> Includes TO-5, TO-18, TO-18A, unmarked 2N numbers, unmarked etc. Cat. No. 1R2603 Untested.	<b>BARREL KIT #62 POLYSTYRENE CAPS 100 for \$1.98</b> Finest caps made. As a gamble we bought 10 barrels from factory, mixed values; 31 good. Cat. No. 1R2729	<b>BARREL KIT #61 POLYSTYRENE CAPS 100 for \$1.98</b> Finest caps made. As a gamble we bought 10 barrels from factory, mixed values; 31 good. Cat. No. 1R2729	<b>BARREL KIT #60 741 MINI DIP "BONANZA" 50 for \$1.98</b> Bargain of a lifetime! All we got was 1 barrel - All the "blister digit" types. Multiple. Cat. No. 1R2722	<b>BARREL KIT #59 741 MINI DIP "BONANZA" 50 for \$1.98</b> Bargain of a lifetime! All we got was 1 barrel - All the "blister digit" types. Multiple. Cat. No. 1R2722	<b>BARREL KIT #58 741 MINI DIP "BONANZA" 50 for \$1.98</b> Bargain of a lifetime! All we got was 1 barrel - All the "blister digit" types. Multiple. Cat. No. 1R2722	<b>BARREL KIT #57 741 MINI DIP "BONANZA" 50 for \$1.98</b> Bargain of a lifetime! All we got was 1 barrel - All the "blister digit" types. Multiple. Cat. No. 1R2722	<b>BARREL KIT #56 POWERS! POWERS! 100 for \$1.98</b> Large distributor cleaned house. Barrels of power resistors 3 to 7 watts. Multiple. Cat. No. 1R2724	<b>BARREL KIT #55 POWERS! POWERS! 100 for \$1.98</b> Large distributor cleaned house. Barrels of power resistors 3 to 7 watts. Multiple. Cat. No. 1R2724	<b>BARREL KIT #54 8 DIGIT READOUTS 10 for \$1.98</b> Bargain of a lifetime! All we got was 1 barrel - All the "blister digit" types. Multiple. Cat. No. 1R2722	<b>BARREL KIT #53 METALLIC RESISTORS 100 for \$1.98</b> Made mostly by Corning. The finest resistor made. Mostly 1/2 watt. 100% 5% tol. & a barrel of values. Cat. No. 1R2609	<b>BARREL KIT #52 METALLIC RESISTORS 100 for \$1.98</b> Made mostly by Corning. The finest resistor made. Mostly 1/2 watt. 100% 5% tol. & a barrel of values. Cat. No. 1R2609	<b>BARREL KIT #51 741 MINI DIP "BONANZA" 50 for \$1.98</b> Bargain of a lifetime! All we got was 1 barrel - All the "blister digit" types. Multiple. Cat. No. 1R2722	<b>BARREL KIT #50 741 MINI DIP "BONANZA" 50 for \$1.98</b> Bargain of a lifetime! All we got was 1 barrel - All the "blister digit" types. Multiple. Cat. No. 1R2722	<b>BARREL KIT #49 741 MINI DIP "BONANZA" 50 for \$1.98</b> Bargain of a lifetime! All we got was 1 barrel - All the "blister digit" types. Multiple. Cat. No. 1R2722	<b>BARREL KIT #48 741 MINI DIP "BONANZA" 50 for \$1.98</b> Bargain of a lifetime! All we got was 1 barrel - All the "blister digit" types. Multiple. Cat. No. 1R2722	<b>BARREL KIT #47 741 MINI DIP "BONANZA" 50 for \$1.98</b> Bargain of a lifetime! All we got was 1 barrel - All the "blister digit" types. Multiple. Cat. No. 1R2722	<b>BARREL KIT #46 741 MINI DIP "BONANZA" 50 for \$1.98</b> Bargain of a lifetime! All we got was 1 barrel - All the "blister digit" types. Multiple. Cat. No. 1R2722	<b>BARREL KIT #45 741 MINI DIP "BONANZA" 50 for \$1.98</b> Bargain of a lifetime! All we got was 1 barrel - All the "blister digit" types. Multiple. Cat. No. 1R2722	<b>BARREL KIT #44 741 MINI DIP "BONANZA" 50 for \$1.98</b> Bargain of a lifetime! All we got was 1 barrel - All the "blister digit" types. Multiple. Cat. No. 1R2722	<b>BARREL KIT #43 741 MINI DIP "BONANZA" 50 for \$1.98</b> Bargain of a lifetime! All we got was 1 barrel - All the "blister digit" types. Multiple. Cat. No. 1R2722	<b>BARREL KIT #42 741 MINI DIP "BONANZA" 50 for \$1.98</b> Bargain of a lifetime! All we got was 1 barrel - All the "blister digit" types. Multiple. Cat. No. 1R2722	<b>BARREL KIT #41 741 MINI DIP "BONANZA" 50 for \$1.98</b> Bargain of a lifetime! All we got was 1 barrel - All the "blister digit" types. Multiple. Cat. No. 1R2722	<b>BARREL KIT #40 741 MINI DIP "BONANZA" 50 for \$1.98</b> Bargain of a lifetime! All we got was 1 barrel - All the "blister digit" types. Multiple. Cat. No. 1R2722	<b>BARREL KIT #39 741 MINI DIP "BONANZA" 50 for \$1.98</b> Bargain of a lifetime! All we got was 1 barrel - All the "blister digit" types. Multiple. Cat. No. 1R2722	<b>BARREL KIT #38 741 MINI DIP "BONANZA" 50 for \$1.98</b> Bargain of a lifetime! All we got was 1 barrel - All the "blister digit" types. Multiple. Cat. No. 1R2722	<b>BARREL KIT #37 741 MINI DIP "BONANZA" 50 for \$1.98</b> Bargain of a lifetime! All we got was 1 barrel - All the "blister digit" types. Multiple. Cat. No. 1R2722	<b>BARREL KIT #36 741 MINI DIP "BONANZA" 50 for \$1.98</b> Bargain of a lifetime! All we got was 1 barrel - All the "blister digit" types. Multiple. Cat. No. 1R2722	<b>BARREL KIT #35 741 MINI DIP "BONANZA" 50 for \$1.98</b> Bargain of a lifetime! All we got was 1 barrel - All the "blister digit" types. Multiple. Cat. No. 1R2722	<b>BARREL KIT #34 741 MINI DIP "BONANZA" 50 for \$1.98</b> Bargain of a lifetime! All we got was 1 barrel - All the "blister digit" types. Multiple. Cat. No. 1R2722	<b>BARREL KIT #33 741 MINI DIP "BONANZA" 50 for \$1.98</b> Bargain of a lifetime! All we got was 1 barrel - All the "blister digit" types. Multiple. Cat. No. 1R2722	<b>BARREL KIT #32 741 MINI DIP "BONANZA" 50 for \$1.98</b> Bargain of a lifetime! All we got was 1 barrel - All the "blister digit" types. Multiple. Cat. No. 1R2722	<b>BARREL KIT #31 741 MINI DIP "BONANZA" 50 for \$1.98</b> Bargain of a lifetime! All we got was 1 barrel - All the "blister digit" types. Multiple. Cat. No. 1R2722	<b>BARREL KIT #30 741 MINI DIP "BONANZA" 50 for \$1.98</b> Bargain of a lifetime! All we got was 1 barrel - All the "blister digit" types. Multiple. Cat. No. 1R2722	<b>BARREL KIT #29 741 MINI DIP "BONANZA" 50 for \$1.98</b> Bargain of a lifetime! All we got was 1 barrel - All the "blister digit" types. Multiple. Cat. No. 1R2722	<b>BARREL KIT #28 741 MINI DIP "BONANZA" 50 for \$1.98</b> Bargain of a lifetime! All we got was 1 barrel - All the "blister digit" types. Multiple. Cat. No. 1R2722	<b>BARREL KIT #27 741 MINI DIP "BONANZA" 50 for \$1.98</b> Bargain of a lifetime! All we got was 1 barrel - All the "blister digit" types. Multiple. Cat. No. 1R2722	<b>BARREL KIT #26 741 MINI DIP "BONANZA" 50 for \$1.98</b> Bargain of a lifetime! All we got was 1 barrel - All the "blister digit" types. Multiple. Cat. No. 1R2722	<b>BARREL KIT #25 741 MINI DIP "BONANZA" 50 for \$1.98</b> Bargain of a lifetime! All we got was 1 barrel - All the "blister digit" types. Multiple. Cat. No. 1R2722	<b>BARREL KIT #24 741 MINI DIP "BONANZA" 50 for \$1.98</b> Bargain of a lifetime! All we got was 1 barrel - All the "blister digit" types. Multiple. Cat. No. 1R2722	<b>BARREL KIT #23 741 MINI DIP "BONANZA" 50 for \$1.98</b> Bargain of a lifetime! All we got was 1 barrel - All the "blister digit" types. Multiple. Cat. No. 1R2722	<b>BARREL KIT #22 741 MINI DIP "BONANZA" 50 for \$1.98</b> Bargain of a lifetime! All we got was 1 barrel - All the "blister digit" types. Multiple. Cat. No. 1R2722	<b>BARREL KIT #21 741 MINI DIP "BONANZA" 50 for \$1.98</b> Bargain of a lifetime! All we got was 1 barrel - All the "blister digit" types. Multiple. Cat. No. 1R2722	<b>BARREL KIT #20 741 MINI DIP "BONANZA" 50 for \$1.98</b> Bargain of a lifetime! All we got was 1 barrel - All the "blister digit" types. Multiple. Cat. No. 1R2722	<b>BARREL KIT #19 741 MINI DIP "BONANZA" 50 for \$1.98</b> Bargain of a lifetime! All we got was 1 barrel - All the "blister digit" types. Multiple. Cat. No. 1R2722	<b>BARREL KIT #18 741 MINI DIP "BONANZA" 50 for \$1.98</b> Bargain of a lifetime! All we got was 1 barrel - All the "blister digit" types. Multiple. Cat. No. 1R2722	<b>BARREL KIT #17 741 MINI DIP "BONANZA" 50 for \$1.98</b> Bargain of a lifetime! All we got was 1 barrel - All the "blister digit" types. Multiple. Cat. No. 1R2722	<b>BARREL KIT #16 741 MINI DIP "BONANZA" 50 for \$1.98</b> Bargain of a lifetime! All we got was 1 barrel - All the "blister digit" types. Multiple. Cat. No. 1R2722	<b>BARREL KIT #15 741 MINI DIP "BONANZA" 50 for \$1.98</b> Bargain of a lifetime! All we got was 1 barrel - All the "blister digit" types. Multiple. Cat. No. 1R2722	<b>BARREL KIT #14 741 MINI DIP "BONANZA" 50 for \$1.98</b> Bargain of a lifetime! All we got was 1 barrel - All the "blister digit" types. Multiple. Cat. No. 1R2722	<b>BARREL KIT #13 741 MINI DIP "BONANZA" 50 for \$1.98</b> Bargain of a lifetime! All we got was 1 barrel - All the "blister digit" types. Multiple. Cat. No. 1R2722	<b>BARREL KIT #12 741 MINI DIP "BONANZA" 50 for \$1.98</b> Bargain of a lifetime! All we got was 1 barrel - All the "blister digit" types. Multiple. Cat. No. 1R2722	<b>BARREL KIT #11 741 MINI DIP "BONANZA" 50 for \$1.98</b> Bargain of a lifetime! All we got was 1 barrel - All the "blister digit" types. Multiple. Cat. No. 1R2722	<b>BARREL KIT #10 741 MINI DIP "BONANZA" 50 for \$1.98</b> Bargain of a lifetime! All we got was 1 barrel - All the "blister digit" types. Multiple. Cat. No. 1R2722	<b>BARREL KIT #9 741 MINI DIP "BONANZA" 50 for \$1.98</b> Bargain of a lifetime! All we got was 1 barrel - All the "blister digit" types. Multiple. Cat. No. 1R2722	<b>BARREL KIT #8 741 MINI DIP "BONANZA" 50 for \$1.98</b> Bargain of a lifetime! All we got was 1 barrel - All the "blister digit" types. Multiple. Cat. No. 1R2722	<b>BARREL KIT #7 741 MINI DIP "BONANZA" 50 for \$1.98</b> Bargain of a lifetime! All we got was 1 barrel - All the "blister digit" types. Multiple. Cat. No. 1R2722	<b>BARREL KIT #6 741 MINI DIP "BONANZA" 50 for \$1.98</b> Bargain of a lifetime! All we got was 1 barrel - All the "blister digit" types. Multiple. Cat. No. 1R2722	<b>BARREL KIT #5 741 MINI DIP "BONANZA" 50 for \$1.98</b> Bargain of a lifetime! All we got was 1 barrel - All the "blister digit" types. Multiple. Cat. No. 1R2722	<b>BARREL KIT #4 741 MINI DIP "BONANZA" 50 for \$1.98</b> Bargain of a lifetime! All we got was 1 barrel - All the "blister digit" types. Multiple. Cat. No. 1R2722	<b>BARREL KIT #3 741 MINI DIP "BONANZA" 50 for \$1.98</b> Bargain of a lifetime! All we got was 1 barrel - All the "blister digit" types. Multiple. Cat. No. 1R2722	<b>BARREL KIT #2 741 MINI DIP "BONANZA" 50 for \$1.98</b> Bargain of a lifetime! All we got was 1 barrel - All the "blister digit" types. Multiple. Cat. No. 1R2722	<b>BARREL KIT #1 741 MINI DIP "BONANZA" 50 for \$1.98</b> Bargain of a lifetime! All we got was 1 barrel - All the "blister digit" types. Multiple. Cat. No. 1R2722
--	--	---	---	--	--	--	--	--	--	---	--	---	--	---	---	---	--	---	--	--	---	--	--	---	--	---	--	--	--	---	--	---	---	--	--	--	--	---	--	--	--	---	---	---	---	---	---	---	--	--	---	---	---	---	---	---	---	---	---	---	---	---	---	---	---	---	---	---	---	---	---	---	---	---	---	---	---	---	---	---	---	---	---	---	---	---	---	---	---	---	---	---	--	--	--	--	--	--	--	--	--

**Poly Paks C-R-A-C-K-S**

**Wow! INCREDIBLE PRICES**

**BUY ANY 10 TAKE 15%**

**BUY 100 TAKE 25%**

<b>TYPE SALE</b>	<b>S7N7400N \$0.16</b>	<b>S7N7442N .53</b>	<b>S7N7494N .78</b>	<b>S7N74160N .88</b>
<b>S7N7401N .16</b>	<b>S7N7443N .65</b>	<b>S7N7495N .72</b>	<b>S7N74161N .88</b>	<b>S7N74162N .88</b>
<b>S7N7402N .16</b>	<b>S7N7444N .79</b>	<b>S7N74100N .98</b>	<b>S7N74165N .99</b>	<b>S7N74166N .99</b>
<b>S7N7403N .16</b>	<b>S7N7447N .69</b>	<b>S7N74106N .65</b>	<b>S7N74171N .97</b>	<b>S7N74172N .97</b>
<b>S7N7404N .16</b>	<b>S7N7448N .76</b>	<b>S7N74112N .65</b>	<b>S7N74175N .89</b>	<b>S7N74176N .89</b>
<b>S7N7405N .18</b>	<b>S7N7450N .19</b>	<b>S7N74113N .65</b>	<b>S7N74176N .79</b>	<b>S7N74177N .79</b>
<b>S7N7406N .20</b>	<b>S7N7451N .19</b>	<b>S7N74114N .65</b>	<b>S7N74181N 2.05</b>	<b>S7N74182N 2.05</b>
<b>S7N7407N .25</b>	<b>S7N7454N .16</b>	<b>S7N74123N .59</b>	<b>S7N74184N 1.75</b>	<b>S7N74185N 1.75</b>
<b>S7N7408N .25</b>	<b>S7N7456N .16</b>	<b>S7N74124N .59</b>	<b>S7N74190N 1.15</b>	<b>S7N74191N 1.15</b>
<b>S7N7409N .18</b>	<b>S7N7470N .49</b>	<b>S7N74125N .59</b>	<b>S7N74191N 1.05</b>	<b>S7N74192N .87</b>
<b>S7N7410N .16</b>	<b>S7N7471N .36</b>	<b>S7N74126N .59</b>	<b>S7N74193N .87</b>	<b>S7N74194N .87</b>
<b>S7N7411N .25</b>	<b>S7N7472N .34</b>	<b>S7N74127N .59</b>	<b>S7N74196N .88</b>	<b>S7N74197N .88</b>
<b>S7N7412N .25</b>	<b>S7N7473N .36</b>	<b>S7N74128N .59</b>	<b>S7N74198N 1.49</b>	<b>S7N74199N 1.49</b>
<b>S7N7413N .45</b>	<b>S7N7474N .31</b>	<b>S7N74129N .59</b>	<b>S7N74200N 3.95</b>	<b>S7N74201N 3.95</b>
<b>S7N7414N .16</b>	<b>S7N7475N .49</b>	<b>S7N74130N .59</b>	<b>S7N74215N 1.05</b>	<b>S7N74216N 1.05</b>
<b>S7N7415N .16</b>	<b>S7N7476N .31</b>	<b>S7N74131N .59</b>	<b>S7N74192N .87</b>	<b>S7N74193N .87</b>
<b>S7N7416N .16</b>	<b>S7N7477N .31</b>	<b>S7N74132N .59</b>	<b>S7N74196N .88</b>	<b>S7N74197N .88</b>
<b>S7N7417N .29</b>	<b>S7N7478N .79</b>	<b>S7N74133N .59</b>	<b>S7N74198N 1.49</b>	<b>S7N74199N 1.49</b>
<b>S7N7418N .25</b>	<b>S7N7483N .59</b>	<b>S7N74134N .59</b>	<b>S7N74200N 3.95</b>	<b>S7N74201N 3.95</b>
<b>S7N7419N .16</b>	<b>S7N7485N .86</b>	<b>S7N74135N .59</b>	<b>S7N74215N 1.05</b>	<b>S7N74216N 1.05</b>
<b>S7N7420N .16</b>	<b>S7N7489N .195</b>	<b>S7N74136N .59</b>	<b>S7N74284N 5.95</b>	<b>S7N74285N 5.95</b>
<b>S7N7421N .35</b>	<b>S7N7490N .44</b>	<b>S7N74137N .59</b>		
<b>S7N7422N .16</b>	<b>S7N7492N .47</b>	<b>S7N74138N .59</b>		
<b>S7N7423N .16</b>	<b>S7N7493N .47</b>	<b>S7N74139N .59</b>		
<b>S7N7424N .16</b>		<b>S7N74140N .59</b>		



# Z-80

## INTRODUCTORY SPECIALS

**RM Z-80 CPU System, w/1K RAM, Monitor ROM, serial-parallel I/O ports, provision for additional I/O ports, PROMS on main board, compatible with existing 8080 software. Complete Kit \$259.95**

**RM-4K Static RAM Board 300ns, for above system, low power 2102's, IC sockets, kit \$139.95**  
Keyboards, Power Supply kits available.

**RM Z-80 System, complete kit with enclosure, shown below, 5K of 300 ns memory, Monitor ROM, keyboard, power supply, ONLY \$529.95**  
w/VIDEO Display Board, add \$99.95  
w/Teletype 33 Printer, used, add \$445.  
RM case, below, holds all of above, including up to 64K of memory.



**16K Static RAM Board, 215 ns access time, extreme low power, kit, RM or Altair/IMSAI version \$479.95**

**Altair/IMSAI 4K Static Memory Board w/2102 RAM's ONLY \$79.95**

High-speed low-power versions available.

**MONITOR 80A Super System Monitor in ROMS for 8080's and Z-80's, replaces over 2K of system memory, supports entry and dump in symbolic, many other routines. Turn your system on and start programming. \$74.95 value, NOW ONLY \$59.95**

**With PROM-ROM Board for Altair/IMSAI, will hold additional 8 PROMS 1K x 8 2708 type Special \$109.95**  
ASSEMBLED and TESTED Boards and Systems available.

8080 and 6800 Systems available at extremely low prices.

Send stamped, self-addressed envelope or contact your favorite dealer.

**MiniMicroMart**  
1618 James Street  
Syracuse, New York 13203  
(315) 422-4467

**H.H. SCOTT Misc Etched & Drilled P.C. Boards Asst.....15-\$1.00**

**SILICON SOLAR CELLS. .4X.8 in. \$1.00  
.8X.8 in. \$1.50**

**GOULD NICADS NEW**  
"AA Cells.....10-\$10.00  
Sub "C" Cells.....10-\$12.00

**GREEN LED .....4-\$1.00  
YELLOW LED  
w/MOUNT COLLAR.....3-\$1.00**

**GALLIUM ARSENIDE  
IRLED EMITTER.....\$1 or 6/\$5.00**

**40 PIN SOCKET FOR MM5314- 5316-  
UART-Etc.....\$1.00 6/\$5.00**

**MAGNETIC RECORDING TAPE 1/2"**  
Audio 1800 Ft. ....\$1.50  
10 for \$12.00  
900 Ft. \$1.15  
10 for \$10.00

*Meshna* **SURPLUS  
ELECTRONIC  
MATERIAL**  
P.O. Box 62  
19 ALLERTON STREET  
E. LYNN MASS. 01904

CIRCLE 30 ON FREE INFORMATION CARD

### U.S. GOV'T ELECTRONIC SURPLUS

\* Nationally Known - World Famous SURPLUS CENTER offers finest, most expensive, Government Surplus electronic units and components at a fraction of their original acquisition cost.

**300-AMP., 200-VOLT RECTIFIER**  
\* (ITEM #22-1048) - FOUR STAR SPECIAL WEST-INGHOUSE, heavy duty unit. Excellent for use in 12 or 24-volt foss chargers, high current power supply systems etc. 3-5/8" x 1-3/8" x 1". (1 lb.)  
**\$6.95** List Over \$20.00

**SNAP-AROUND VOLT-AMMETER**  
\* (ITEM #21-1028) - "MINIPROBE" clamp type AC ammeter-voltmeter. Small enough to carry in shirt pocket. Will measure 0 to 50-amperes, 0 to 250-volts. Furnished with test leads. Overall size 4-1/2" x 2-3/4" x 1". (1 lb.) List \$33.00  
**\$22.95**

**STANDARD DIAL TELEPHONE**  
\* (ITEM #715) - Same as used on commercial systems in U.S.A. Use as extension to private system. Connect several together for local intercom system. Instructions furnished  
**\$8.79** Original Cost \$24.50 (9 lbs.)

**RUNNING TIME METER**  
\* (ITEM #2188) - Record number of operating hours of electric lights, electrical devices such as refrigerators, furnaces, etc. Records total hours tenths and hundredths to 9,999.99 hours. For 115-volts, 60-cycles. 4 1/4" x 3" x 2 1/2". (2 lbs.)  
**\$4.39** Cost \$29.00

**SPECIAL SALE Correspondence Course In ELECTRICAL ENGINEERING**  
Prepaid in U.S.A. **\$11.79**  
Outside U.S.A. **\$12.79**

\* (ITEM #9-181) - Technical training at low cost! Lincoln Engineering School suspended Correspondence Course because of rising costs. Limited number of Electrical Engineering Courses are available without exams and grading services. Consists of fifteen lesson books, each with associated exams and standard answers. Book showing how to build prize-winning Home Experimental Laboratory Bench included at no extra cost.

ALL ITEMS SHIPPED F.O.B. LINCOLN, NEBR.  
Order Direct From Ad - Send For FREE Catalog  
**SURPLUS CENTER**  
DEPT. RE-126 LINCOLN, NEBR. 68501

CIRCLE 3 ON FREE INFORMATION CARD

www.americanradiohistory.com



**FASCINATING microcomputer kits!** Build inexpensively ASCII keyboard, paper tape reader, teletypewriter interface, tri-voltage PS. Construction manuals \$2 each. 1702A Programming-\$1. Free Catalogue. **MICROTRONICS**, P.O. Box 7454, D101, Menlo Park, CA 94025

**ECONOMY kits, Super-Pong TV game by "Visulex" (June "R-E") complete kit \$150.00; TVT-III (W/2K memory capability) \$114.75; screen read \$11.65; manual cursor \$9.50; cassette-computer interface, dual recorder, 1000 baud \$28.50; motion detector (ultrasonic); assembled \$18.75; 4K memory card (2102) \$75.00; 2K/4K (word) EPROM card kit, less EPROMS \$55.00, (W/8EA 1702A) \$111.00 W/16EA 1702A \$167.00), boards available separately. **ELECTRONIC DISCOUNT SALES**, 138 N. 81st Street, Mesa, AZ 85207**



### SHOOT OUT

JUST ONE OF THE 16 GAMES YOU CAN PLAY WITH OUR NEW INCREDIBLE HAND HELD ELECTRONIC GAME SATISFACTION GUARANTEED ASSEMBLED & PPD. **\$8.95**  
KIT \$6.95  
INTERFAB, 27959T CABOT RD. LAGUNA NIGUEL, CA. 92677

**KITS, semiconductors, components. Fast delivery, free flyer. CHIPS ELECTRONICS**, Box 1030, Oakville, Ont., Canada L6J5E9. U.S. Inquiries invited.



### ORGAN KITS KEYBOARDS.

THE ULTIMATE IN DESIGN AND SOUND  
DEMO RECORD AND BROCHURE \$1.00

Wurlitzer reproductions

**DEVTRONIX ORGAN PRODUCTS**, Dept. 4B  
5872 Amapola Dr. • San Jose, CA 95129

**LINEAR amplifier, 3-30 MHz, 100 watt mobile. Construction plans, \$3.00. WILSON**, Box 5516-FA, Walnut Creek, CA 94596

### EDUCATION & INSTRUCTION

**TELEPHONE bugged? Don't be Watergated!** Countermeasures brochure \$1.00. **NEGEYE LABORATORIES**, Box 547-RE, Pennsboro, WV 26415

**F.C.C. EXAM MANUAL**  
PASS FCC EXAMS! Memorize, study—Tests Answer for FCC 1st and 2nd class Radio telephone licenses. Newly revised multiple choice questions and diagrams cover all areas tested in FCC exams, plus Self Study Ability Test \$9.95 postpaid Money back guarantee  
**COMMAND PRODUCTIONS** P.O. Box 26348 E  
RADIO ENGINEERING DIV. SAN FRANCISCO, CAL. 94126

**FREE educational electronics catalog. Home study courses. Write to: EDUKITS WORKSHOP**, Dept. 287G, Hewlett, NY 11557

**GRANTHAM's FCC License Study Guide—377 pages, 1465 questions with answers/discussions—covering third, second, first radiotelephone examinations. \$10.70 postpaid. GSE PUBLICATIONS**, 2000 Stoner, Los Angeles, CA 90025



# S.D. SALES CO.

P.O. BOX 28810 - C  
DALLAS, TEXAS 75228

## Z-80 CPU CARD KIT FOR IMSAI/ALTAIR

# \$149.<sup>KIT</sup>

From the same people who brought you the \$89.95 4K RAM kit. We were not the first to introduce an IMSAI/ALTAIR compatible Z-80 card, but we do feel that ours has the best design and quality at the lowest price.

The advanced features of the Z-80 such as an expanded set of 158 instructions, 8080A software compatibility, and operation from a single 5VDC supply, are all well known. What makes our card different is the extra care we took in the hardware design. The CPU card will always stop on an M1 state. We also generate TRUE SYNC on card, to insure that the rest of your system functions properly. Dynamic memory refresh and NMI are brought out for your use. Believe it or not, not all of our competitors have gone to the extra trouble of doing this.

As always, this kit includes all parts, all sockets, and complete instructions for ease of assembly. Because of our past experience with our 4K kit we suggest that you order early. All orders will be shipped on a strict first come basis. Dealers inquiries welcome on this item.

Kit shipped with 2 MHz crystals for existing 500NS memory. Easily modified for faster RAM chips when the prices come down.  
Z-80 Manual - \$7.50 Separately.

Kit includes Zilog Manual and all parts.

JUMBO  
LED  
CAR  
CLOCK

# \$16.95

KIT

You requested it! Our first DC operated clock kit. Professionally engineered from scratch to be a DC operated clock. Not a makeshift kluge as sold by others. Features: Bowmar 4 digit .5 inch LED array, Mostek 50252 super clock chip, on board precision time base, 12 or 24 hour real time format, perfect for cars, boats, vans, etc. Kit contains PC Board and all other parts needed (except case). 50,000 satisfied clock kit customers cannot be wrong!

FOR ALARM OPTION ADD \$1.50  
FOR XFMR FOR AC OPERATION ADD \$1.50

## 60 HZ CRYSTAL TIME BASE FOR DIGITAL CLOCKS S.D. SALES EXCLUSIVE!

### KIT FEATURES:

- A. 60HZ output with accuracy comparable to a digital watch.
- B. Directly interfaces with all MOS Clock Chips.
- C. Super low power consumption. (1.5 ma typ.) **\$5.95 or 2/\$10.**
- D. Uses latest MOS 17 stage divider IC.
- E. Eliminates forever the problem of AC line glitches.
- F. Perfect for cars, boats, campers, or even for portable clocks at ham field days.
- G. Small Size, can be used in existing enclosures.

KIT INCLUDES CRYSTAL, DIVIDER IC, PC BOARD PLUS ALL OTHER NECESSARY PARTS & SPECS

## 50HZ CRYSTAL TIME BASE KIT - \$6.95

All the features of our 60HZ kit but has 50HZ output. For use with clock chips like the 50252 that require 50HZ to give 24 hour time format.

### THIS MONTH'S SPECIALS!

- 300.00 KHZ CRYSTAL - \$1.50
  - 8080A - CPU CHIP by AMD - \$19.95
  - 82S129 - 256 x 4 PROM - \$2.50
  - N.S. 8865 OCTAL DARLINGTON DRIVERS  
3 for \$1.00
  - Z-80 - CPU by ZILOG - \$69.95
  - MM5204 - 4K EPROM - \$7.95
- Prices in effect this month ONLY!

SPECIAL

SPECIAL

## 4K LOW POWER RAM BOARD KIT THE WHOLE WORKS - \$89.95

Imsai and Altair 8080 plug in compatible. Uses low power static 21L02-1 500ns. RAM's, which are included. Fully buffered, drastically reduced power consumption, on board regulated, all sockets and parts included. Premium quality plated thru PC Board.

## SIGNETICS ANALOG MANUAL - \$5.95

Just out! From the acknowledged leader in linear technology. Theory, applications, and specs. on op amps, timers, phase locked loops, etc. 637 pages.

A MUST For Any Technical Library!

STICK IT!  
in your clock  
in your DVM, etc.!

Huge Special Purchase  
Not Factory Seconds  
As sold by others!

# \$3.95

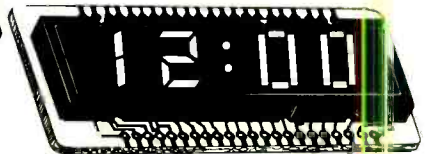

4 JUMBO .50"  
DIGITS ON  
ONE STICK!  
(with colons and  
AM/PM Indicator)

BUY 3 for \$10.

## BOWMAR 4 DIGIT LED READOUT ARRAY

The Bowmar Opto-Stick. The best readout bargain we have ever offered. Has four common cathode jumbo digits with all segments and cathodes brought out. Increased versatility since any of the digits may be used independently to fit your applications. Perfect for any clock chip, especially direct drive units like 50380 or 7010. Also use in freq. counters, DVM's, etc. For 12 or 24 hour format.

## UP YOUR COMPUTER!

### 21L02-1 1K LOW POWER 500 NS STATIC RAM TIME IS OF THE ESSENCE!

And so is power. Not only are our RAM'S faster than a speeding bullet but they are now very low power. We are pleased to offer prime new 21L02-1 low power and super fast RAM'S. Allows you to STRETCH your power supply farther and at the same time keep the wait light off. **8 for \$12.95**

## HOUSE NO. TTL

- |                 |                 |                  |
|-----------------|-----------------|------------------|
| 7400 - 8/\$1.00 | 7420 - 8/\$1.00 | 74141 - 3/\$1.00 |
| 7404 - 8/\$1.00 | 7437 - 5/\$1.00 | 74153 - 3/\$1.00 |
| 7408 - 8/\$1.00 |                 | 7438 - 5/\$1.00  |

Please specify that you are ordering House No. TTL.

## WESTERN DIGITAL UART

No. TR1602B. 40 pin DIP  
This is a very powerful and popular part.

NEW-\$6.95 with data  
LIMITED QUANTITY



## RESISTOR ASSORTMENT

¼ W 5% and 10%  
PC leads. A good mix  
of values. 200/\$2.

## FAIRCHILD BIG LED READOUTS

A big .50 inch easy to read character. Now available in either common anode or common cathode. Take your pick. Super low current drain, only 5MA per segment typical.

FND 510 Common Anode  
FND 503 Common Cathode  
PRICE SLASHED! 59c each

### TERMS:

Money Back Guarantee. No COD. Texas Residents add 5% tax. Add 5% of order for postage and handling. Orders under \$10. add 75c. Foreign orders: US Funds ONLY!

## SLIDE SWITCH ASSORTMENT

Our best seller. Includes miniature and standard sizes, single and multi-position units. All new, first quality, name brand. Try one package and you'll reorder more. **SPECIAL 12/\$1.**



## MOTOROLA POWER DARLINGTON Back in Stock!

Like MJ3001. NPN 8CV, 10A, HFE 6000 TYP. TO-3 case. We include a free 723C volt reg. with schematic for power supply. **SPECIAL-\$1.99**

CALL YOUR BANK  
AMERICARD OR MASTER  
CHARGE ORDER IN ON  
OUR CONTINENTAL  
UNITED STATES TOLL  
FREE WATTS:

**1-800-527-3460**  
Texas Residents Call Collect  
**214/271-0022**

S.D. SALES CO.  
P.O. BOX 28810 C  
Dallas, Texas 75228

7400N TTL

Table listing various TTL components such as SN7400N, SN7401N, SN7402N, etc., with their respective quantities and prices.

MANY OTHERS AVAILABLE ON REQUEST 20% Discount for 100 Combined 7400's

CMOS

Table listing CMOS components such as CD4000, CD4001, CD4002, etc., with their respective quantities and prices.

LINEAR

Table listing linear components such as LM3004, LM3005, LM3008, etc., with their respective quantities and prices.

74LS00 TTL

Table listing 74LS00 TTL components such as 74LS00, 74LS01, 74LS02, etc., with their respective quantities and prices.

CLOCK CHIPS

Table listing clock chips such as MM5939, MM5112, MM5114, etc., with their respective quantities and prices.

DATA HANDBOOKS

7400 Pin-out & Description of 5400 7400 ICs \$2.95 CMOS Pin-out & Description of 4000 Series ICs \$2.95 Linear Pin-out & Description of 7400 Series ICs \$2.95 ALL THREE HANDBOOKS \$6.95

FAIRCHILD TECHNOLOGY KITS FAIRCHILD

Advertisement for Fairchild Technology Kits, listing various kits like DIGITS, PHOTO ARRAYS, COUPLERS, MOS CLOCK CIRCUITS, LED LAMPS, PHOTO TRANSISTORS, and KITS with their descriptions and prices.

DISCRETE LEDES

Table listing discrete LEDs with specifications like size (125, 200, 385, 485, 685), color (Red, Green, Orange, Yellow, Clear), and price.

DISPLAY LEDES

Table listing display LEDs with specifications like type (MAN 1-84), polarity, height, and price.

IC SOLDERTAIL — LOW PROFILE (TIN) SOCKETS

Table listing IC solder tail sockets with specifications like pin count (8, 14, 16, 18, 20, 22, 24, 28, 30, 32, 36, 40, 44, 48, 52, 56, 60, 64, 68, 72, 76, 80, 84, 88, 92, 96, 100) and price.

SOLDERTAIL STANDARD (TIN)

Table listing solder tail standard (tin) sockets with specifications like pin count and price.

SOLDERTAIL STANDARD (GOLD)

Table listing solder tail standard (gold) sockets with specifications like pin count and price.

WIRE WRAP SOCKETS (GOLD) LEVEL #3

Table listing wire wrap sockets (gold) level #3 with specifications like pin count and price.

WIRE WRAP TOOL

Advertisement for Wire Wrap Tool, showing the tool and its features, with a price of \$5.95 ea.

WIRE WRAP WIRE

Table listing wire wrap wire with specifications like gauge (30 AWG), length (25 ft, 50 ft, 100 ft, 200 ft), and price.

50 PCS. RESISTOR ASSORTMENTS \$1.75 PER ASS'T.

Table listing resistor assortments with specifications like ASST. 1-8R, resistor values, and price.

\$5.00 Minimum Order — U.S. Funds Only Spec Sheets - 25¢ — Send 24 Stamp for 1977 Catalog California Residents — Add 6% Sales Tax Dealer Discount Available — Request Pricing

Advertisement for James Electronics, featuring the company logo, address (1021-A HOWARD AVE., SAN CARLOS, CA 94070), phone number ((415) 592-8097), and a note about advertised prices.

Advertisement for Miniature Toggle switches, showing a toggle switch and its specifications.

Advertisement for Push Button switches, showing a push button and its specifications, including PB-123 and PB-126 for \$1.75.

Advertisement for Thumbwheel Switches, showing a thumbwheel switch and its specifications.

Advertisement for Dip Switches, showing a dip switch and its specifications, including SPST and SPDT types.

Advertisement for Cliplite mounting system, showing a clip and its specifications, including a price of \$1.95.

Advertisement for Zeners, Diodes, and Rectifiers, showing various components and their specifications.

Advertisement for SCR and FW Bridge Rectifiers, showing various components and their specifications.

Advertisement for Transistors, showing various components and their specifications.

Advertisement for Capacitors, showing various components and their specifications.

Advertisement for Corner capacitors, showing various components and their specifications.





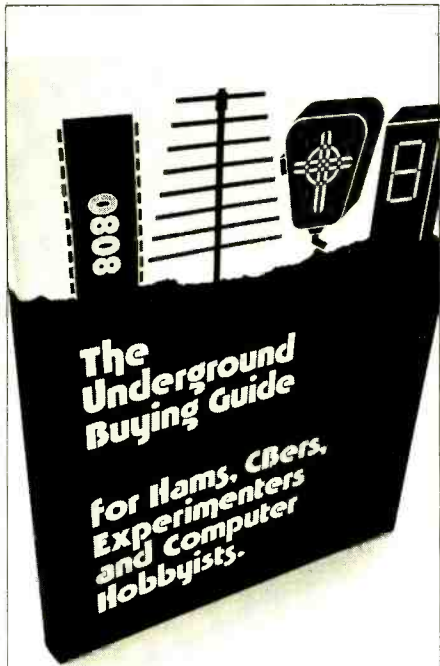

## Where to get it.

Equipment, parts, supplies and services. Hard to find and standard items at bargain prices.

Over 600 places to find transceivers, antennas, surplus, new and used equipment,  $\mu$ Ps/computers, ICs, components, assortments, assemblies, discounted items, test equipment, peripherals, etc. Hundreds of large and small mail order sources.

A complete directory divided by sources, items and locations. Saves countless hours of shopping. Easily pays for itself through comparative buying. Contains no advertising.

Rush my order. I enclose \$5.95 plus 55¢ postage and handling. Californians add 39¢ sales tax. Full refund if not completely satisfied within 10 days.

Name \_\_\_\_\_

Address \_\_\_\_\_

City/State/Zip \_\_\_\_\_

Primary interest: Amateur Radio  CB   
 Experimenting   $\mu$ Ps/Computers

Send to: Peninsula Marketing  
 Dept. B  
 12625 Lido Way  
 Saratoga, CA 95070

## EQUIPMENT REPORTS

continued from page 29

be useful in checking touchy circuits where meter loading is important. The action is the same on any scale.

The inputs of both are electrically protected; DVM-35 up to 1,000 volts and DVM-36 up to 2,000 volts. An internal shunt diode is used. Beside this: if you unscrew the red tip of the probe, you'll find a fast-blow 2.0A fuse! This is nice for those places where "you didn't know the gun was loaded!". If you do manage to pop this fuse, be sure to use a fast-blow type for replacement. This is a standard 2A 3AG fuse.

A slip-on high-voltage probe, HP200, can be used to go up to 50 kV. This can also be used on lower voltage ranges if a very high impedance is needed.

Both models are powered by 6 AA batteries inside the case. NiCad batteries can be used; a recharger unit, PA-202, can be used for bench work. The unit can be used for portable work by pulling the charger plug. Battery condition may be checked at any time by setting to the 10- or 20-volt DC scale and touching the tip of the charger-socket terminal.

The instruction manual covers all possible uses of the instrument. A service manual, parts list and color-coded schematic diagram are included. Test and calibration procedures are given in the back pages. A novel feature is used, for the benefit of those who are new to digital voltmeters. A tape cassette, with recorded instructions and references to pages of the manual, comes with every instrument. This can be played while reading the manual and checking the instrument. **R-E**

## TV corporations, labor unions ask for color TV import quotas

Eleven labor organizations and five corporations have petitioned the United States International Trade Commission for import quotas on color TV sets. The petition is one of the largest yet filed under the escape clause provisions of the new Trade Act that was made into law last year. All but one of the petitioners—GTE Sylvania, Inc.—are banded together in a new organization, the Committee to Preserve American Color Television (COMPACT).

"Imports from abroad have already captured two-thirds of the American market for black-and-white, and they are now moving aggressively to capture the more than \$2 billion-plus domestic market for color receivers," says Allen W. Dawson, executive vice president of Corning Glass Works and co-chairman of COMPACT. *Business Week* reports that "the Japanese now claim 31 percent of the United States color TV set market."

According to Jacob Clayman, secretary-treasurer of the AFL-CIO Industrial Union Department, the other co-chairman of COMPACT, "some 65,000 jobs are at stake in this action (the petition) and many of these have been lost already." He reported that ten years ago, an estimated 240,000 imported color sets were sold in this country. By 1975, imports had risen to 1,214,000 sets and at the current rate of increase they are expected to exceed two million in 1976.

## BUSINESS OPPORTUNITIES

### HIGHLY PROFITABLE ONE-MAN ELECTRONIC FACTORY

Investment unnecessary, knowledge not required, sales handled by professionals. Ideal home business. Write today for facts! Postcard will do. Barta-BM, Box 248, Walnut Creek, CA 94597.

INCREASE TV set sales with your own, exclusive newspaper column. For free details, write TELEVISION TIPS, P.O. Box 157, Clarkston, GA 30021

### YOUR HOBBY EXPENSES ARE TAX DEDUCTIBLE!

FOR FREE INFORMATION WRITE FINANCIAL MANAGEMENT ASSOC., INC. BOX 82129 AD SAN DIEGO, CA 92138

## WANTED

QUICK cash . . . for electronic equipment, components, unused tubes. Send list now! BARRY, 512 Broadway, New York, NY 10012, 212 Walker 5-7000

## TV JAMMER

Amaze your friends! Makes TV's go into distortion. Max. range 20'. IN EASY KIT FORM. . . \$2.65

\* SEND FOR FREE CATALOG \*

PPS ELECTRONICS COMPANY  
 6827 Tobias Av. Van Nuys Ca. 91405

WANTED old Rider's, Sams', Supreme manuals. BEITMAN, 1760 Balsam, Highland Park, IL 60035

U.S. FEDERAL RESERVE  
 STATEMENT OF OWNERSHIP, MANAGEMENT AND CIRCULATION

1. TITLE OF PUBLICATION: GLOBE PUBLICATIONS, INC.  
 2. NUMBER OF ISSUES PUBLISHED ANNUALLY: 12  
 3. DATE OF NEXT PUBLICATION: 1978  
 4. YEAR OF PUBLICATION: 1977  
 5. FULL NAME AND COMPLETE ADDRESS OF PUBLISHER: GLOBE PUBLICATIONS, INC., 200 BROAD AVENUE, NEW YORK, N.Y. 10003  
 6. FULL NAME AND COMPLETE ADDRESS OF EDITOR-IN-CHIEF: LARRY STOKLEY, 200 BROAD AVENUE, NEW YORK, N.Y. 10003  
 7. FULL NAME AND COMPLETE ADDRESS OF BUSINESS MANAGER: LARRY STOKLEY, 200 BROAD AVENUE, NEW YORK, N.Y. 10003  
 8. FULL NAME AND COMPLETE ADDRESS OF OWNER: GLOBE PUBLICATIONS, INC., 200 BROAD AVENUE, NEW YORK, N.Y. 10003  
 9. FULL NAME AND COMPLETE ADDRESS OF STOCKHOLDER: GLOBE PUBLICATIONS, INC., 200 BROAD AVENUE, NEW YORK, N.Y. 10003  
 10. FULL NAME AND COMPLETE ADDRESS OF ADVERTISING SALES REPRESENTATIVE: GLOBE PUBLICATIONS, INC., 200 BROAD AVENUE, NEW YORK, N.Y. 10003  
 11. FULL NAME AND COMPLETE ADDRESS OF CIRCULATION DEPARTMENT: GLOBE PUBLICATIONS, INC., 200 BROAD AVENUE, NEW YORK, N.Y. 10003  
 12. FULL NAME AND COMPLETE ADDRESS OF HEADQUARTERS: GLOBE PUBLICATIONS, INC., 200 BROAD AVENUE, NEW YORK, N.Y. 10003  
 13. FULL NAME AND COMPLETE ADDRESS OF PRINTING OFFICE: GLOBE PUBLICATIONS, INC., 200 BROAD AVENUE, NEW YORK, N.Y. 10003  
 14. FULL NAME AND COMPLETE ADDRESS OF DISTRIBUTION OFFICE: GLOBE PUBLICATIONS, INC., 200 BROAD AVENUE, NEW YORK, N.Y. 10003  
 15. FULL NAME AND COMPLETE ADDRESS OF SALES OFFICE: GLOBE PUBLICATIONS, INC., 200 BROAD AVENUE, NEW YORK, N.Y. 10003  
 16. FULL NAME AND COMPLETE ADDRESS OF SUBSCRIPTION OFFICE: GLOBE PUBLICATIONS, INC., 200 BROAD AVENUE, NEW YORK, N.Y. 10003  
 17. FULL NAME AND COMPLETE ADDRESS OF HEADQUARTERS: GLOBE PUBLICATIONS, INC., 200 BROAD AVENUE, NEW YORK, N.Y. 10003  
 18. FULL NAME AND COMPLETE ADDRESS OF HEADQUARTERS: GLOBE PUBLICATIONS, INC., 200 BROAD AVENUE, NEW YORK, N.Y. 10003  
 19. FULL NAME AND COMPLETE ADDRESS OF HEADQUARTERS: GLOBE PUBLICATIONS, INC., 200 BROAD AVENUE, NEW YORK, N.Y. 10003  
 20. FULL NAME AND COMPLETE ADDRESS OF HEADQUARTERS: GLOBE PUBLICATIONS, INC., 200 BROAD AVENUE, NEW YORK, N.Y. 10003



## COMPLETE ALARM CLOCK

- \* 4 Digits 0.5" LED with brightness control
- \* 12 Hour display with AM/PM indication
- \* True 24 hour alarm with repeatable snooze
- \* Power failure indication for power interrupt



MODEL EC 400  
(Not A Kit)  
**Only \$22.50**  
ON SALE **\$17.50 ea.**

## RCA FM-AM MUX TUNER



ALL BRAND NEW  
BUT NO CASE  
(Power Supply  
Not Included)

**Special Price \$16.00 each**

## RCA 12 WATT PER CHANNEL FM-AM MUX TUNER AMP



FM-AM MUX  
TUNER AMP  
All brand new  
but no case.

**Special Price \$35.00 each**

## CLOCK KITS! THE MOST POPULAR MM5314 KIT



WITH A NEW CASE!!  
Features: 12/24 Hour Display  
50/60 HZ Input 6 Digits Readout  
Kit includes Grey Color Plastic Case  
MM5314 Clock Chip PC Boards and Trans-  
former, 6 Green Color 0.3" Tube Readouts,  
All other transistor Drivers and other Com-  
ponents.

**Special Only \$19.95 ea.**

## MODEL CT7001



0.5" Green  
Color Displays  
6 Digits  
with MONTH & DATE  
30/60HZ and ALARM

**Only \$28.50 ea.**

CASE ONLY \$6.00 EACH

## COMPUTER KEYBOARDS



Standard Teletype Keyboards with gold plated contact switches. All switches are independent and allow you to connect into any form of output.

**Only \$22.50**

## ASCII KEYBOARD ENCODER CHIP G1AY-5-3600



40 pin DIP package, 4 level, 10 BITS per level, encoding for up to 90 keys. Latched data outputs and control signal output, TTL compatibility for all controls.

WITH DATA ONLY \$18.50 EACH

COMPLETE ASCII DECODED KEYBOARD KIT (Using the above 64 key keyboard and the AY-5 encoder chip.) Kit includes keyboard, PC board, encoder LSI chip, TTLIC, LED, all electronic components and the instructions.  
**ONLY \$54.50**

## VOLTAGE REGULATORS

### ALL POSITIVE OUTPUT FAIRCHILD 78 MG



Adjustable Volt Regulators  
500MA 5V 30V Output  
with data ONLY \$1.60 ea.  
LM340T 1 amp Output  
5V, 6V, 9V, 12V, 15V, 24V  
Positive only \$1.10 ea.

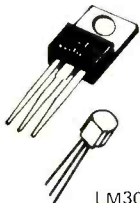

MINI SIZE REGULATOR  
in TO-92 package  
78L05, 78L012 by Fairchild  
Low Power 100MA Output  
Only \$0.80 ea.

LM309K 5V 1amp TO-3 \$1.00 ea.

## 3 AMP POWER SUPPLY



UA723 REGULATED  
Output 5V and 12V  
Input 110AC

**only \$19.50**

\*Postage  
for this item  
\$2.50



12 VDC Relay  
SPDT 4 amp  
\$1.25 ea.

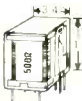

MINI SIZE  
12V RELAY  
DTDT 500  
\$1.40 ea.

## 5V REED RELAY



DPST Normal  
Open in a DIP  
Package

\$2.25 each / 2 for \$4.00

## AC ADAPTERS



110V AC Input  
4.5V 100MA 6V 100MA  
9V 100MA 12V 100MA  
\$2.85 each  
12V 150MA AC output \$2.00 ea.

## TRANSFORMERS



110V input  
12 0 12V 1amp \$2.25 ea  
12V CT 500MA  
with one group 165V \$1.50 ea  
0.3 12 24V 500MA \$2.75 ea

## NI-CD FAST CHARGE BATTERIES BY SANYO



Rechargeable AA Size  
ALL BRAND NEW  
\$1.25 each 4 for \$4.50

## AUTO ALARM KIT



The Com-Rite Auto Alarm is an electronic self controlled auto-protection system, normally mounted within the glove box of an automobile.

Two minutes after turning off the ignition, the alarm automatically turns itself "on". When the auto is restarted, the horn will sound after a 10-15 second entry delay. The automobile owner, by inserting the ignition key, will activate the alarm. Once activated, the alarm will sound for two minutes before automatically turning off. The alarm then resets and is ready to again protect the vehicle from unwanted entry.

FEATURES: Simple installation 5 wires. Automatically turns on when auto is parked. Adjustable entry time. Extended exit time to allow for unattended exit from vehicle. Numerous applications include protection of boats, campers, trailers, motor cycles, trucks. Cannot be deactivated by "hot wiring" an auto. Can not be turned off without ignition key. Negative ground only.

ONLY \$10.00 per kit Completed Unit \$16.00

## LED READOUTS

### LARGE CLOCK PANEL!



1 1/2" high, 4 digit, 7 segment orange color gas discharge tube Supply voltage 120 165V  
SIZE 4 1/2" x 1 9/16" \$9.95 Each  
Buy the transformer with the display. You only pay \$1.50 each.



Fairchild FSC 8000  
0.8" Red LED 3-Digit with AM/PM  
Red Color  
Direct Drive by MM 5316 or Fairchild 3817  
\$10.50 ea.

## JUMBO LED



Fairchild FND 800  
0.8" Common Cathode  
Red Color  
ONLY \$3.50 ea.



7 Seg LED  
MAN 74 Red \$1.00  
MAN 84 Yellow \$1.50  
HP 0.3" Red \$1.20  
DL 747 Red \$2.50  
DL 727 Double Digit \$2.50  
DL 707 0.3" Red \$1.30  
FND 70 0.25" Red \$0.60  
FND 503 0.5" Red \$1.60  
FLV 50 Submini Red \$0.15 ea  
FLV 209 Mini Rvd \$0.15 ea  
Jumbo Rvd \$0.15 ea  
Jumbo Green \$0.25 ea  
Jumbo Orange \$0.25 ea

## 50 U A PANEL METER



First designed for metal Finder Scaled from 0 10 but can be erased and your own scale put on too. Brand new in box.  
Only \$3.80 ea.

Size 2 1/2" x 2 1/2"

## 150UA METER

only \$1.50 ea.

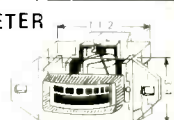

## QUAD VOLUME CONTROL JOY STICK



4 100K Volume pot in one unit vary resistance proportional to the angle of the stick. Perfect for electronic games or model remote control.

only \$5.50

## ELECTRONIC SWITCH KIT

### CONDENSER TYPE

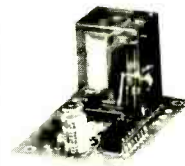

Touch on Touch Off  
use 7473 I.C.  
and 12V relay  
\$5.50 each

## FM WIRELESS MIC KIT

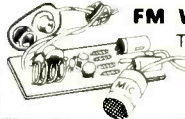

Transmit range up to 500ft.  
Easy to assemble  
\$4.50 each

Sub-Mini Size  
Condenser Microphone  
\$2.50 each



## SW AUDIO AMP KIT



USE 2 LM330  
with Volume Control  
POWER SUPPLY 6V DC  
only \$5.00 ea.

## SAE DIP SWITCHES



Part No. 1004 692 4XSPST SW  
100B 692 8XSPST SW  
4 Toggle SPST Switches on a Mini DIP (18 pins) Only \$1.50 ea.  
8 Toggle SPST Switches on a DIP (16 pins) Only \$2.50 ea.

## SUBMINIATURES TOGGLE SWITCHES



SPDT On-Off \$3.30 ea.  
DPDT On-Off \$1.50 ea.  
3PDT On-Off \$1.75 ea.

## ECCO BCD THUMBWHEEL SWITCHES



8 positions \$1.25 ea.  
10 positions \$2.5 ea.  
12 positions \$2.50 ea.

## COLORFUL SUB MINI PUSH BUTTON SWITCH

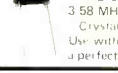

Non-Open Contact  
Color: Red, Green, Yellow, Black  
4 for \$1.00

## QUARTZ CRYSTALS



1MHz Computer Crystal \$2.25 ea.  
3.58 MHz Color TV Crystals \$1.25 ea.  
Use with Nation MM 5316 to make a perfect time base for clock.

## COMPLETE 60HZ DC TIME BASE KIT



Kit includes MM5369, XTAL, capacitor, resistor and PC board  
SPECIAL PRICE ONLY \$5.25 each

## THUMBWHEEL TRIM POTS



VALVE 300R 2K 25K 5K, 10K, 12K, 50K, 1M  
Special Offer: 5 for \$1.00

## SOLID STATE ELECTRONIC BUZZER



Mini Size 1 1/2" x 1 1/2"  
Supply voltage 1.5V 12V  
Ideal for Alarm or Tone Indicator  
\$1.50 Each



# FORMULA INTERNATIONAL INC.

12603 CRENSHAW BOULEVARD • HAWTHORNE, CALIFORNIA 90250

For more information please call (213) 679-5162

STORE HOURS 10-7 Monday - Saturday





TTL 7400N			
SN7400N	15	SN74121N	36
SN7401N	15	SN74122N	42
SN7402N	15	SN74123N	59
SN7403N	15	SN74125N	45
SN7404N	18	SN74126N	45
SN7405N	18	SN74128N	65
SN7405N	18	SN74132N	84
SN7406N	34	SN74136N	64
SN7407N	34	SN74141N	93
SN7408N	18	SN74142N	3.70
SN7409N	18	SN74143N	3.98
SN7410N	15	SN74144N	3.98
SN7411N	21	SN74145N	89
SN7412N	28	SN74147N	1.68
SN7413N	41	SN74148N	1.25
SN7414N	79	SN74150N	99
SN7416N	26	SN74151N	63
SN7417N	31	SN74153N	63
SN7420N	15	SN74154N	99
SN7421N	21	SN74155N	78
SN7422N	21	SN74156N	69
SN7423N	27	SN74157N	64
SN7425N	27	SN74159N	2.50
SN7426N	24	SN74160N	89
SN7427N	27	SN74161N	89
SN7428N	35	SN74162N	89
SN7430N	15	SN74163N	89
SN7432N	24	SN74164N	1.10
SN7433N	35	SN74165N	99
SN7437N	23	SN74166N	1.19
SN7438N	23	SN74167N	2.98
SN7440N	15	SN74170N	1.75
SN7442N	38	SN74172N	8.75
SN7443N	38	SN74173N	1.29
SN7444N	85	SN74174N	99
SN7445N	74	SN74175N	89
SN7446AN	78	SN74176N	79
SN7447AN	78	SN74177N	78
SN7448N	74	SN74178N	1.25
SN7450N	15	SN74179N	1.60
SN7451N	15	SN74180N	69
SN7453N	15	SN74181N	1.99
SN7454N	15	SN74182N	69
SN7456N	28	SN74184N	1.89
SN7457N	28	SN74185AN	1.89
SN7472N	27	SN74186N	6.95
SN7473N	31	SN74188N	3.50
SN7474N	31	SN74190N	1.09
SN7475N	48	SN74191N	1.09
SN7476N	34	SN74192N	88
SN7480N	39	SN74193N	88
SN7481AN	99	SN74194N	94
SN7482N	59	SN74195N	59
SN7483AN	69	SN74196N	93
SN7484AN	1.65	SN74197N	83
SN7485N	88	SN74198N	1.69
SN7486N	32	SN74199N	1.69
SN7489N	1.95	SN74221N	1.20
SN7490AN	45	SN74246N	1.95
SN7491AN	64	SN74247N	1.85
SN7492AN	46	SN74248N	1.75
SN7493AN	46	SN74249N	1.75
SN7494N	74	SN74251N	1.40
SN7495AN	69	SN74255N	85
SN7496N	69	SN74278N	2.45
SN7497N	2.85	SN74279N	59
SN74100N	83	SN74283N	1.45
SN74104N	43	SN74284N	4.50
SN74105N	43	SN74285N	4.50
SN74107N	29	SN74290N	85
SN74109N	49	SN74293N	85
SN74110N	54	SN74298N	1.98
SN74111N	74	SN74351N	1.92
SN74116N	1.75	SN74356N	65
SN74120N	1.40	SN74366N	65
		SN74367N	65
		SN74358N	65
		SN74390N	1.40
		SN74393N	1.40
		SN74490N	1.90

ZENER DIODES		
IN4728—IN4752A	19	(1 watt molded)
IN746A—IN759A	15	(400 MW)

TTL LOW POWER SCHOTTKY			
SN74LS00N	25	SN74LS138N	1.49
SN74LS01N	25	SN74LS139N	1.49
SN74LS02N	25	SN74LS145N	1.25
SN74LS03N	25	SN74LS151N	1.25
SN74LS04N	30	SN74LS153N	1.25
SN74LS05N	30	SN74LS155N	1.45
SN74LS08N	25	SN74LS156N	1.45
SN74LS09N	25	SN74LS157N	1.25
SN74LS10N	25	SN74LS158N	1.20
SN74LS11N	25	SN74LS160N	1.95
SN74LS12N	25	SN74LS161N	1.95
SN74LS13N	69	SN74LS162N	1.95
SN74LS14N	1.35	SN74LS163N	1.95
SN74LS15N	25	SN74LS164N	1.25
SN74LS20N	25	SN74LS168N	2.25
SN74LS21N	25	SN74LS169N	2.25
SN74LS22N	25	SN74LS170N	2.80
SN74LS26N	40	SN74LS174N	1.40
SN74LS27N	30	SN74LS175N	1.40
SN74LS28N	30	SN74LS181N	3.50
SN74LS30N	25	SN74LS190N	1.95
SN74LS32N	37	SN74LS191N	1.95
SN74LS33N	39	SN74LS192N	1.95
SN74LS37N	39	SN74LS193N	1.95
SN74LS38N	39	SN74LS194A	1.40
SN74LS40N	30	SN74LS195A	1.40
SN74LS42N	1.10	SN74LS196N	1.45
SN74LS48N	1.10	SN74LS197N	1.45
SN74LS47N	1.10	SN74LS221N	1.35
SN74LS48N	1.10	SN74LS240N	2.50
SN74LS49N	1.10	SN74LS241N	2.50
SN74LS51N	25	SN74LS242N	2.40
SN74LS54N	25	SN74LS243N	2.40
SN74LS55N	25	SN74LS244N	2.50
SN74LS56N	1.75	SN74LS247N	1.30
SN74LS57N	49	SN74LS248N	1.30
SN74LS57AN	49	SN74LS249N	1.30
SN74LS57SN	69	SN74LS251N	1.55
SN74LS576N	49	SN74LS253N	1.55
SN74LS578N	49	SN74LS257N	1.60
SN74LS583AN	1.49	SN74LS258N	1.60
SN74LS585N	1.75	SN74LS261N	2.95
SN74LS586N	58	SN74LS266N	59
SN74LS590N	99	SN74LS279N	75
SN74LS591N	1.15	SN74LS283N	1.40
SN74LS592N	1.10	SN74LS290N	1.35
SN74LS593N	1.10	SN74LS293N	1.35
SN74LS593BN	99	SN74LS295AN	1.75
SN74LS595AN	1.60	SN74LS298AN	1.75
SN74LS596N	1.75	SN74LS324AN	2.25
SN74LS107N	49	SN74LS325AN	1.45
SN74LS109N	55	SN74LS352AN	1.45
SN74LS112N	49	SN74LS353AN	1.70
SN74LS113N	49	SN74LS365AN	75
SN74LS114N	49	SN74LS366AN	75
SN74LS122N	89	SN74LS387AN	75
SN74LS123N	1.09	SN74LS388AN	75
SN74LS124N	1.95	SN74LS375AN	80
SN74LS125N	75	SN74LS386AN	59
SN74LS126N	75	SN74LS395AN	1.95
SN74LS132N	1.25	SN74LS670AN	2.95
SN74LS136N	55		

We offer the largest variety of current production Texas Instruments and Fairchild Semiconductor only 74LS devices from stock. Even through the competition for current production major manufactured 74LS devices is limited, we are dedicated to provide the best prices possible. As our costs decrease, we pass the savings on to you, our customer.

### TEXAS INSTRUMENTS DATA BOOKS

STK NO.	DESCRIPTION	PRICE
LCB1011	Understanding Solid State Electronics	2.95
LCB1041	Linear & Interface Applications	6.95
LCC4041	Power Data Book	3.95
LCC4111	TTL Data Book	3.95
LCC4131	Transistor & Diode Data Book	4.95
MCC4151	Linear & Interface I.C. Data Book	3.95
LCC4161	TTL Supplement Data Book	1.95
LCC4191	Optoelectronics Data Book	2.95
LCC4200	Semiconductor Memories Data Book	2.95

### FAIRCHILD DATA BOOKS

Linear Integrated Circuits Data Book	2.95
Low Power Schottky & Macrologic TTL	1.75
MOS, CMOS, MOS/P-MOS & charge coupled Devices	2.50
Interface Data Book	1.00
Full Line Condensed Catalogue	1.95

### GENERAL INSTRUMENT DATA BOOK

Microelectronic & MOS Data Book	2.95
STANDARD MICROSYSTEMS	
8 Bit Uart	7.95
Universal Synchronous Receiver Transmitter	23.50
8 Bit Uart	8.50

CMOS		
CD4000BE	10	
CD4001BE	19	
CD4002BE	14	
CD4006BE	1.19	
CD4007BE	18	
CD4008BE	85	
CD4009BE	39	
CD4010BE	19	
CD4011BE	39	
CD4012BE	18	
CD4013BE	39	
CD4014BE	95	
CD4015BE	95	
CD4016BE	99	
CD4017BE	39	
CD4018BE	1.09	
CD4019BE	44	
CD4020BE	1.09	
CD4021BE	1.15	
CD4022BE	95	
CD4023BE	19	
CD4024BE	69	
CD4025BE	18	
CD4026BE	1.45	
CD4027BE	44	
CD4028BE	79	
CD4029BE	89	
CD4030BE	39	
CD4033BE	1.70	
CD4034BE	2.95	
CD4035BE	1.05	
CD4040BE	1.05	
CD4041BE	60	
CD4042BE	65	
CD4043BE	50	
CD4044BE	50	
CD4049BE	39	
CD4050BE	39	
CD4051BE	1.20	
CD4052BE	1.20	
CD4053BE	1.25	
CD4055BE	3.35	
CD4056BE	1.50	
CD4060BE	1.50	
CD4066BE	65	
CD4068BE	25	
CD4069BE	25	
CD4070BE	25	
CD4071BE	25	
CD4072BE	30	
CD4073BE	30	
CD4075BE	30	
CD4078BE	1.10	
CD4081BE	25	
CD4082BE	30	
CD4085BE	75	
CD4086BE	75	
CD4502BE	1.20	
CD4507BE	54	
CD4510BE	1.10	
CD4512BE	1.50	
CD4516BE	1.19	
CD4518BE	99	
CD4519BE	89	
CD4520BE	89	
CD4528BE	1.25	
CD4531BE	1.25	
CD4539BE	1.20	
CD4555BE	75	
CD4556BE	75	
CD4585BE	1.80	
74C85 40085PC	1.20	
74C160 40160PC	1.65	
74C161 40161PC	1.65	
74C162 40162PC	1.65	
74C163 40163PC	1.65	
74C174 40174PC	1.50	
74C175 40175PC	1.50	
74C192 40192PC	1.65	
74C193 40193PC	1.65	
74C194 40194PC	1.65	
74C195 40195PC	1.50	

LED's		
Ltronix		
IL1	1.05	
IL5	1.15	
IL12	.69	
IL74	.82	
RL2	23	
Texas Instruments		
TIL111	.99	
TIL112	.95	
TIL113	1.25	
TIL114	1.15	
TIL116	1.20	
TIL117	1.30	
TIL118	.80	
TIL119	.85	
TIL138	2.25	
TIL139	2.25	
TIL209A	.18	
TIL211	.39	
TIL220	.20	
TIL221	.19	
TIL222	.35	
TIL23	1.98	
TIL24	3.95	
TIL302	3.98	
TIL303	3.98	
TIL304	3.98	
TIL305	4.95	
TIL306	7.95	
TIL307	7.95	
TIL308	7.95	
TIL309	7.95	
TIL311	8.95	
TIL312	1.60	
TIL313	1.60	
TIL314	1.60	
TIL315	1.50	
TIL32	8.50	
TIL32	1.85	
TIL63	95	
TIL66	75	
TIL78	1.20	
TIL81	1.20	
LS600	2.10	

Plastic Power Transistors			
TIP29A	45	TIP111	80
TIP30C	59	TIP112	90
TIP31A	52	TIP113	1.25
TIP32A	55	TIP114	1.50
TIP33C	90	TIP115	1.35
TIP41A	65	TIP116	1.60
TIP42A	75	TIP117	89
TIP47	88	TIP118	85
TIP112	80	TIP119	85

LINEARS		
LM301AH		.34
LM301AN-8	(mini dip)	.34
LM304H		.75
LM305H		.78
LM305AH		.90
LM307H		.28
LM307N-8	(mini dip)	.28
LM308H		.84
LM309H		.75
LM309K		1.15
LM311H		.89
LM311H-8	(mini dip)	.99
LM318H		1.50
LM318N-8	(mini dip)	1.25
LM323K		6.95
LM324N		1.10
LM339N		1.20
LM555N-8	(mini dip)	.44
LM556N-14		.89
LM709CN-14		.24
LM711CN-14		.29
LM711CH		.50
LM723CH		.49
LM723CN-14		.49
LM733CN-14		.99</



**10% OFF WITH \$25 ORDER**  
**15% OFF WITH \$100 ORDER**

THESE DISCOUNTS APPLY TO TOTAL OF ORDER — SPECIALS INCLUDED

**LINEAR CIRCUITS**

304	Neg V Reg TO-5	.80
305	Pos V Reg TO-5	.71
307	Op AMP (super 741) mDIP TO-5	.26
308	Micro Pwr Op Amp mDIP TO-5	.89
309K	5V 1A regulator TO-3	1.35
310	V follower Op Amp mDIP	1.07
311	Hi per V Comp mDIP TO-5	.95
319	Hi Speed Dual Comp DIP	1.13
320T	Neg Reg 5.12 TO-220	1.39
322	Precision Timer DIP	1.39
324	Quad Op Amp DIP	1.52
339	Quad Comparator DIP	1.58
140K	Pos V Reg (5V, 6V, 8V, 12V, 15V, 18V, 24V) TO-1	1.69
340T	Pos V Reg (5V, 6V, 8V, 12V, 15V, 18V, 24V) TO-220	1.49
370	AGC/Squelch AMPLI DIP	1.20
372	AF-IF Strip detector DIP	2.93
373	AM FM SSB Strip TO-5	2.42
376	Pos V Reg mDIP	.68
380	2w Audio Amp DIP	1.30
180-B	1w Audio Amp mDIP	1.25
381	Lo Noise Dual preamp DIP	1.75
382	Lo Noise Dual preamp DIP	1.75
531	High Slew rate Op Amp	2.95
540	Power driver TO-5	2.95
550	Pri V Reg DIP	1.02
555	Timer mDIP	.45
556A	Dual 555 Timer DIP	1.19
560	Phase Locked Loop DIP	3.39
562	Phase Locked Loop DIP	3.39
565	Phase Locked Loop DIP TO-5	1.18
566	Function Gen mDIP TO-5	1.95
567	Tone Decoder mDIP	1.95
709	Operational AMP TO-5 or DIP	.26
710	Hi Speed Volt Comp DIP	.35
711	Dual Difference Compar DIP	.26
723	V Reg DIP	.62
733	Diff. video AMPLI TO-5	1.02
739	Dual Hi Peril Op Amp DIP	1.07
741	Comp Op Amp mDIP TO-5	.32
747	741 Dual Op Amp DIP or TO-5	.71
748	Freq Adj 741 mDIP	.35
1304	FM Mulps Stereo Demod DIP	1.07
1307	FM Mulps Stereo Demod DIP	.74
1456	Op Amp mDIP	1.83
1458	Dual Comp Op Amp mDIP	.62
1800	Stereo multiplexer DIP	2.48
3900	Quad Amplifier DIP	.49
7524	Dual core memory sense Amp	.71
7525	Dual core memory sense Amp	.90
8038	Voltage contr. osc. DIP	4.16
8864	9 DIG Led Cath Drvr DIP	2.25
75150	Dual Line Driver DIP	1.75
75451	Dual Peripheral Driver mDIP	.35
75452	Dual Peripheral Driver mDIP	.35
75453 (151)	Dual Periph Driver mDIP	.35
75491	Quad Seq Driver for LED DIP	.71
75492	Hex Digit driver DIP	.80

**IC SOCKETS**

**Solder Tail - low profile**

8 pin	\$ .17	24 pin	.42
14 pin	.20	28 pin	.59
16 pin	.22	40 pin	.69
18 pin	.29		

**WIRE WRAP - gold plate**

14 pin	.49
--------	-----

**TTL**

7400	.13	7451	.17	74153	.89
7401	.16	7453	.17	74154	1.20
7402	.15	7454	.17	74155	.97
7403	.15	7460		74156	.97
7404	.16	7464	.35	74157	.99
7405	.19	7465	.35	74158	1.79
7406	.20	7470	.30	74160	1.23
7407	.28	7472	.30	74161	.97
7408	.18	7473	.35	74162	1.39
7409	.19	7474	.28	74163	1.09
7410	.16	7475	.49	74164	.99
7411	.25	7476	.30	74165	.99
7413	.43	7483	.68	74166	1.25
7414	.65	7485	.88	74170	2.10
7416	.35	7486	.40	74173	1.49
7417	.35	7489	2.25	74174	1.23
7420	.16	7490	.43	74175	.97
7422	.30	7491	.75	74176	.89
7423	.29	7492	.48	74177	.84
7425	.27	7493	.48	74180	.90
7426	.26	7494	.78	74181	2.45
7427	.29	7495	.79	74182	.79
7430	.20	7496	.79	74184	1.90
7432	.23	74100	.98	74185	2.20
7437	.25	74105	.44	74187	5.75
7438	.25	74107	.37	74190	1.15
7440	.15	74121	.38	74191	1.25
7441	.89	74122	.38	74192	.95
7442	.59	74123	.65	74193	.85
7443	.73	74125	.54	74194	1.25
7444	.73	74126	.58	74195	.74
7445	.73	74132	.89	74916	1.25
7446	.81	74141	1.04	74197	.73
7447	.79	74145	1.04	74198	1.73
7448	.79	74150	.97	74199	1.69
7450	.17	74151	.79	74200	5.45

Data included with order on request. Add \$.30 ea. if item is priced below \$1.00

**CENTRAL PROCESSING UNIT**

8008	\$19.95
8080	\$19.95
1702A	2048 bit static PROM elect. prog. - UV eras. 24 pin \$6.95
2102	1024 BIT STATIC RAM DTL/TTL comp. 16 pin 1.49

**RESISTOR KIT**



180 carbon film resistors ± 5%, 1/4 or 1/2 watt. 15 each of 12 values. utility box \$9.95

**TANTALUM CAPACITOR KIT \$9.95**

50 solid dipped tantalum capacitors - 20% tolerance capacitors in a durable styrene utility box - with color code charts  
 5 each 1 ufd 35V 33 ufd 35V 1 ufd 35V 22 ufd 35V 4.7 ufd 16V 4.7 ufd 6V 10 ufd 25V 15 ufd 20V 22 ufd 16V 33 ufd 10V 40 ufd 6V 56 ufd 6V

**DVM CHIP 4 1/2 DIGIT**

MM 5330 - P channel device provides all logic for 4 1/2 digit volt meter. 16 pin DIP with data \$8.95

**POCKET CALCULATOR KIT**



5 function plus constant - adjustable memory with individual recall - 8 digit display plus overflow. battery saver - uses standard or rechargeable batteries - all necessary parts in ready to assemble form - instructions included

Calc. Kit. Kit only	\$ 9.95
Batteries (alkaline, disp.)	2.00
Adapter	4.95

**SHIFT REGISTERS**

MM5013	1024 bit accum. dyn.	1.75
MM5016	500/512 bit dyn.	1.59
55-4025	Quad 25 bit	.99
2504	1024 bit multiplexed dyn	3.95

**TANTALUM CAPACITORS**

Solid dipped +20%

.1 mfd	35V	\$.25	10 mfd	16V	\$.40
.33 mfd	35V	.25	10 mfd	25V	.45
1 mfd	35V	.25	15 mfd	10V	.40
2.2 mfd	20V	.25	15 mfd	20V	.45
2.2 mfd	35V	.30	22 mfd	16V	.45
3.3 mfd	35V	.30	33 mfd	10V	.40
4.7 mfd	16V	.30	47 mfd	6V	.40
6.8 mfd	6V	.30	56 mfd	6V	.45
6.8 mfd	50V	.40	150 mfd	15V	.50

**CMOS**

4000A	.26	4018A	1.39	4066A	.89
4001A	.25	4020A	1.72	4068A	.44
4002A	.25	4021A	1.18	4069A	.44
4006A	1.35	4022A	.94	4071A	.26
4007A	.26	4023A	.25	4072A	.35
4008A	1.52	4024A	.89	4073A	.39
4009A	.57	4025A	.25	4075A	.39
4010A	.54	4027A	.59	4078A	.39
4011A	.29	4028A	.98	4082A	.35
4012A	.25	4030A	.44	4518A	1.56
4013A	.45	4035A	1.27	4528A	1.56
4014A	1.27	4040A	1.39	4585A	2.10
4015A	1.27	4042A	1.47		
4016A	.48	4049A	.59		
4017A	1.01	4050A	.59		

74C00	.19	74C74	1.04	74C162	2.49
74C02	.26	74C76	1.34	74C163	2.66
74C04	.44	74C107	1.13	74C164	2.66
74C08	.68	74C151	2.62	74C173	2.22
74C10	.35	74C154	3.15	74C195	2.26
74C20	.35	74C157	1.76	80C95	1.15
74C42	1.61	74C160	2.48	80C97	.96
74C73	1.04	74C161	2.49		

**CLOCK CHIPS**

MM5311	6 digit multiplexed BCD, 7 seg, 12-24 Hr, 50-60 Hz	28 pin	4.45
MM5312	4 digit multiplexed BCD, 7 seg, lpps, 12-24 Hr, 50-60 Hz	24 pin	3.95
MM5314	6 digit multiplexed 12-24 Hr, 50-60 Hz	24 pin	4.45
MM5316	4 digit, 12-24 Hr, 50-60 Hz, alarm	40 pin	4.95
537AA	4-6 digit, 12 hour, 60 Hz snooze alarm brightness control capability, alarm tone output - 24 pin		4.95
CT7001	6 digit, 12-24 Hr, 50-60 Hz, alarm, timer and date circuits - 28 pin		\$6.95

**CALCULATOR CHIPS**

CT5002	8 digit, 4 function fixed decimal battery operation - 40 pin	1.95
CT5005	12 digit, 4 function plus memory, fixed decimal - 20 pin	2.49
MM5725	8 digit, 4 function, floating decimal 18 pin	1.98
MM5736	6 digit, 4 function, 9V battery operation - 18 pin	2.95
MM5738	8 digit, 5 function plus memory and constant floating decimal, 9V battery operation - 24 pin	3.95
MM5739	9 digit, 4 function, 9V battery operation - 22 pin	3.95

**JANUARY SPECIALS**

MEMORIES		TTL	LINEAR	LED	
1103	.95	7410	.12	301 mDIP .22	MV108 .10
5261	.95	7437	.20	307 DIP .22	MV50 .20
F93410	1.39	7474	.22	565 DIP .97	5020 RED .12
		74121	.29	741 mDIP .22	DL10A 1.69
		9602	.49	739 DIP .89	MANS .98
CALCULATOR CHIP					
MM5738	\$1.75				

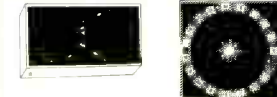

**Electronic Games**  
 A great gift idea or for your own family entertainment center. We have available in kit form **Electronic Roulette** and **Electronic Craps**. Both kits contain P.C. boards, LEDs, all necessary components, transformer, case and instructions for easy assembly. Included with each kit is a 55 page booklet explaining the entire game.

**Electronic Roulette**  
 Dimensions 6 1/2" x 6 1/2" x 1 1/2" \$23.95

**Electronic Craps**  
 Dimensions 6 1/2" x 3 1/2" x 1 1/2" \$14.95

**AUTO CLOCK KIT**  
 6 digits .375" rev led's  
 Operates from 12V DC or AC  
 Crystal control for high accuracy  
 Supplied with case  
 & mounting bracket  
 Contains internal 9V battery for operation of timing circuit (without display)  
 when removed temporarily from power.  
 Uses 5314 clock circuit  
 Supplied with all necessary components and assembly instructions  
**\$33.95**  
**COMPLETELY ASSEMBLED \$44.95**

**MEMORIES**

1101	256 bit RAM MOS 16 pin	1.39
1103	1024 bit RAM MOS dynamic 18 pin	1.95
1702A	2048 bit PROM static electrically programmable UV erasable 24 pin	10.95
2102	1024 bit RAM static 16 pin	1.95
5203	2048 bit PROM static electrically programmable UV erasable 24 pin	10.95
5260	1024 bit RAM MOS dynamic 16 pin	1.95
5261	1024 bit RAM MOS dynamic 16 pin	1.95
5262	2048 bit dynamic RAM	2.25
7489	64 bit ROM TTL 16 pin	2.25
82523	256 PROM-SCHOTTKY 16 pin	3.69
F93410	256 bit RAM bi-polar 16 pin	1.95
74187	1024 bit ROM TTL 16 pin	5.75
74200	256 bit RAM tri-state 16 pin	5.45

**OPTO ISOLATORS**

MCD2	Opto isolator diode	1.09
MCT2	Opto isolator transistor	.70

**MULTIPLE DISPLAYS**

NSN33	3 digit 12" red LED	1.79
HP5082-	5 digit .11 red LED	3.49
7405		
HP5082-	4 digit .11 red LED	3.25
7414		
SP-425-09	9 digit .25 gas disch.	1.79

**SPECIAL DEVICES**

372	AF-IF Strip Detector DIP	2.93
546	AM Radio Receiver Subsystem DIP	.75
1310	FM Stereo Demodulator DIP	2.90
1496	Balanced Modulator-Demodulator	.99
1800	Stereo multiplexer DIP	2.48
ULN2208	FM Gain Block 34db (typ) mDIP	1.18
ULN2209	FM Gain Block 48db (typ) mDIP	1.35
2513	Character Generator 64x8x5 DIP-24	10.20
3046	Transistor Array DIP-14	.73

**Mark I**  
 A six digit clock kit with one double sided P.C. board accommodates MM5314 clock chip and 6 FND359 .375" displays. 12-24 hour, 50-60 Hz. Contains all necessary components, 3 switches and complete assembly instructions with schematics. Connections for remote displays.

**Mark I** ..... \$13.95

**6 Digit Clock Kit**  
 MM5314 with 6 NS71 .27" displays 2 P.C. boards - Display board may be remote. Internal or wall transformer can be used. 50-60 Hz, 12-24 hour. Includes all necessary transistors, resistors, capacitors, diodes, 3 switches and complete assembly instructions.

**CK6-3** ..... \$14.95

**4 Digit Clock Kit**  
 MM5312 and 4 NS71 .27" displays 12-24 hours, 50-60 Hz. One P.C. board accommodates clock display, and all necessary transistors, resistors, capacitors, diodes, 2 switches, complete instructions and schematics for assembly.

**CK4-2** ..... \$10.95

**Transformers**  
 117VAC - 12V 300 ma PC Mount. \$3.95

117 VAC - 12V 300 ma wall mount \$4.95

Optional case available for all of the above clocks. Unfinished redwood designed individually for each clock. Internal or wall transformers may be used.



Mark I - 2 1/2" x 3 1/4" x 5"  
 CK6-3 - 2 1/2" x 3" x 4 1/2"  
 CK4-2 - 3 1/2" x 3 1/4" x 3" \$4.95

**DISCRETE LED'S**

MAN1	\$1.95	ME4	\$.29
MAN2	3.95	MV50	.12
MAN3A	.19	NSL100	.12
MANS	2.25	NSL101	.12
MAN6	2.49	NSL102	.15
MAN7	1.49	MV5020	
MAN8	2.25	RED	.15
MAN66	2.25	GREEN	.15
DL10A	2.19	AMBER	.15
FND500	1.89	CLEAR	.15
NS7			





# LIVE IN THE WORLD OF TOMORROW... TODAY!

And our FREE 164 PAGE CATALOG is packed with exciting and unusual values in electronic, hobby and science items — plus 4,500 finds for fun, study or profit... for every member of the family.

## A BETTER LIFE STARTS HERE

### SUPER POWER FOR ANY AM RADIO

New antenna assist turns a tiny transistor into a tiger, has pulled in stations 1000\* miles away! Just set beside radio (no wires, clips, grounding) and fine-tune Select-A-Tenna's dial to same frequency—"gangbusters"! Great for clearing weak signals in radio depressed areas, off-coast islands, crowded frequency stations. Solid state—uses no electricity, batts., tubes.



Stock No. 72,095 EH.....\$19.95 Ppd.  
Ultra Select-A-Tenna No. 72,147 EH  
(\*Over 1000 MI.).....\$24.95 Ppd.

### NASA-CHOSEN FOR APOLLO/SOYUZ

157 mi. out in space, the Astronauts used this super 20x60 binocular (modified) to view Earth! Our biggest, most powerful for distance. Far-off objects come in big, clear & sharp to the edge through big 60mm objective lenses; 173-ft. field of view at 1000 yds. Relative brightness, 9.0. Fully coated optics; 20X spcl design eye lenses. Coated BK-7 Porro prism. Extra long All-American style with fold-down rubber eyecups. Includes case & straps.



No. 1556EH... (9 1/4 x 8 1/2"; 47.5 oz.).....\$119.95 Ppd.  
8 x 30 European style  
No. 1559EH... (4 1/2 x 6 1/4"; 19 oz.).....\$39.50 Ppd.

### Electronic Digital STOPWATCH: \$39.95

The price alone obsoletes your wind up timer and it's +0.002% accurate! Hand held, you start, stop, reset compact 6-ounce w/one hand; times to 59 mins, 59.9 secs in 1/10 increments. Failsafe design (cannot be accidentally reset), solid-state electronics! Incis neckstrap, repl. batts.



No. 1671EH... (5-DIGIT LED DISPLAY).....\$39.95 Ppd.  
SPLIT ACTION W/NICADS, RECHARGER  
No. 1669EH... (5-DIGIT LED DISPLAY).....\$79.95 Ppd.  
DELUXE SPLIT ACTION BATTERY MODEL  
No. 1653EH... (6-DIGIT NEON DISPLAY).....\$149.95 Ppd.

### AN ALPHA MONITOR FOR \$37.50?

Yes, because you built it! Use your ability to tune in your brainwaves, an aid to relaxation, concentration. Kit incl. everything you need (except 9v trans. batt.) to own a portable self-cont. BIOFEEDBACK unit for a pittance; steth. earphones, electrode headband, solid-state circuitry; 5 microvolt sensitivity, more! Compl. assembly instructions & op. manual. With basic electronics knowledge, you can do it!



No. 61,069EH (KIT).....\$37.50 Ppd.  
No. 71,809EH (FULLY ASSEMBLED).....\$59.95 Ppd.

## NEW! THE UNIQUE EDMUND 4 1/4", f/4 NEWTONIAN RICHEST FIELD REFLECTOR TELESCOPE.

Clearlest, brightest, most spectacular wide angle views of moon, stars, comets, galaxies ever—and portable! See heavenly wonders! Sets up in seconds (precollimated, ready to use). Pop the eyepiece in, focus—and zing! 3 1/2" field of view gives you more stars in a single view than any other type 'scope.' Bright, crisp, finely resolved images. For sky gazing and earth gazing! Take it anywhere (only 17", 10 lb.), easily use it over your shoulder, (has adjustable carrying strap), in your lap, on a tripod; rotate the spherical base on its own mount for use on a table, car hood. Top quality optical system features 4 1/4", f/4 parabolic primary mirror (1/4 wave, 1.7" F.L.); std. 28mm Kellner eyepiece (15X). No other telescope like it. It's even bright red!

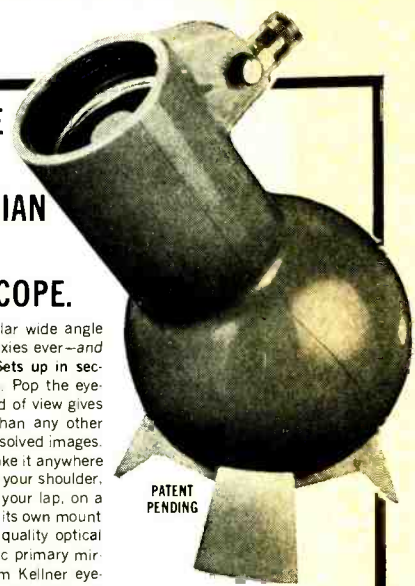

No. 2001EH.....\$149.95 Ppd.

### 18 HOURS' WEATHER COMPUTERIZED

Glance at our Weather Wizard and know what to expect for the next 8-18 hrs. Roofmounted windvane sends pulses to indoor control unit programmed w/75 yrs. data; interprets on 3 panel lights (Unsettled, Fair, Change). Be up to 80-85% accurate (better than most pro's)!



Based on wind—no charts, dials—no computations! Program WW for your location once, then forecasting is automatic. Who needs TV! Incis vane, support, 60 ft. of cable. 5x4 1/2 x 3 1/2" control unit, instruc.

No. 72,200EH... (110V, 60 CYCLES).....\$99.95 Ppd.

### KNOW YOUR ALPHA FROM THETA!



For greater relaxation, concentration, listen to your Alpha-Theta brainwaves. Ultra-sensitive electrode headband slips on/off in seconds—eliminates need for messy creams, etc. Atch'd to amplifier, filters brainwaves, signals beep for ea. Alpha or Theta wave passed. Monitoring button simulates Alpha sound; audio & visual (L.E.D.) feedback. Reliable, easy-to-use unit—comparable to costlier models. Completely safe. Comprehensive instruction booklet.

No. 1635 EH... (8x3x4"; 24 oz.).....\$149.50 Ppd.  
LOW COST "STARTER" UNIT  
No. 71,809 EH.....\$ 59.95 Ppd.

### 3000 MI. POWER FOR AM RADIOS

Remarkably Clearer Reception!



Get ball games from distant cities, your old home town, up to 3000 miles away (subject to local conditions). Deluxe Ultrasensitive AM Antenna pre-amplifies signal before it goes

into your hi-fi AM receiver or tuner inputs. Nulls interference. Great for marginal AM reception areas! Shielded ferrite rod 6 3/4 lb. directional indoor antenna has 2-stage FET amplifier with frequency & sensitivity controls for precise selection, optimum reception. Easily atch'd: 110VAC, 60 cycles.

No. 72,263EH... (3-3/8x9-1/16x11").....\$177.50 Ppd.

## MAIL COUPON FOR GIANT FREE CATALOG!

164 PAGES • MORE THAN 4500 UNUSUAL BARGAINS



Completely new 1977 edition. New items, categories, illustrations. Dozens of electrical and electromagnetic parts, accessories. Enormous selection of Astronomical Telescopes. Unique lighting and ecological items. Microscopes, Binoculars, Magnifiers, Magnets, Lenses, Prisms. Hard-to-get surplus bargains. Ingenious scientific tools. 1000's of components.

EDMUND SCIENTIFIC CO.  
300 Edscorp Building, Barrington, N.J. 08007  
Please rush Free Giant Catalog "EH".

Name \_\_\_\_\_  
Address \_\_\_\_\_  
City \_\_\_\_\_ State \_\_\_\_\_ Zip \_\_\_\_\_



## COMPLETE AND MAIL WITH CHECK, M. O. OR CHARGE NO.

EDMUND SCIENTIFIC CO. 300 Edscorp Building, Barrington, N.J. 08007

(609) 547-3488

How Many	Stock No.	Description	Price Each	Total

PLEASE SEND GIANT FREE CATALOG "EH"

Charge my  American Exp.  BankAmericard  Master Cng

Interbank No. \_\_\_\_\_

My Card No. Is \_\_\_\_\_

Card Expiration Date \_\_\_\_\_

30-DAY MONEY-BACK GUARANTEE.

You must be satisfied or return any purchase in 30 days for full refund.

Name \_\_\_\_\_

Address \_\_\_\_\_

City \_\_\_\_\_ State \_\_\_\_\_ Zip \_\_\_\_\_

Add Handling Charge \$1.00

I enclose  check  money order for TOTAL \$ \_\_\_\_\_

Signature \_\_\_\_\_



# The Reference Solution Is Vastly Improved.

## Introducing D3

- significantly higher “activity” ratios.
- incredibly low parts-per-billion but highly effective anti-static system.
- a chemical “release system” that allows fluid and suspended compounds to pull away from record micro-grooves.



Only from  
Discwasher labs.  
Better performance  
without increased  
price.

 Discwasher  
Group

1407 N. PROVIDENCE  
COLUMBIA, MO 65201



# THE COBRA 32XLR. A TECHNOLOGICAL PUNCHTHROUGH.

Cobra has a reputation for punching through loud and clear. The new Cobra 32XLR, of course, continues the reputation. And creates another – for innovative design, superb engineering and technical superiority.

Start with the illuminated 4-in-1 meter. It tells you exactly how much power you're pushing out and pulling in. As well as monitoring your modulation in precise percentages. And measuring your punch with an SWR check. In short, the 32 XLR lets you keep an eye on your ears.

ScanAlert, Cobra's unique scanning system, continually monitors Channel 9 when you're on another channel. If an emergency comes up, the ScanAlert light goes on. And the incoming message automatically locks the receiver on the active channel.

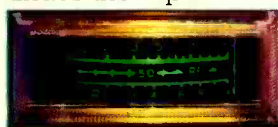

The 32XLR's Digital Channel Selector is the very latest. With large LED numerals – for a read-out that registers clearly and quickly. Plus switchable "pulse block" noise blanking that rejects short-pulse noise not normally blocked by other systems. Which makes it the most effective in the business. Finally, add automatic noise limiting, Dynamike Plus (with built-in power mike) and Delta Tuning.

The new Cobra 32XLR. It has virtually everything. And it has everything to do just one thing. Punch through loud and clear.



**Punches through loud and clear.**

Cobra Communications Products  
DYNASCAN CORPORATION  
6460 W. Cortland St., Chicago, Illinois 60635